

INSTALLATION INSTRUCTIONS

SERIES IT600 THERMALLY INSULATED HURRICANE RESISTANT STOREFRONT

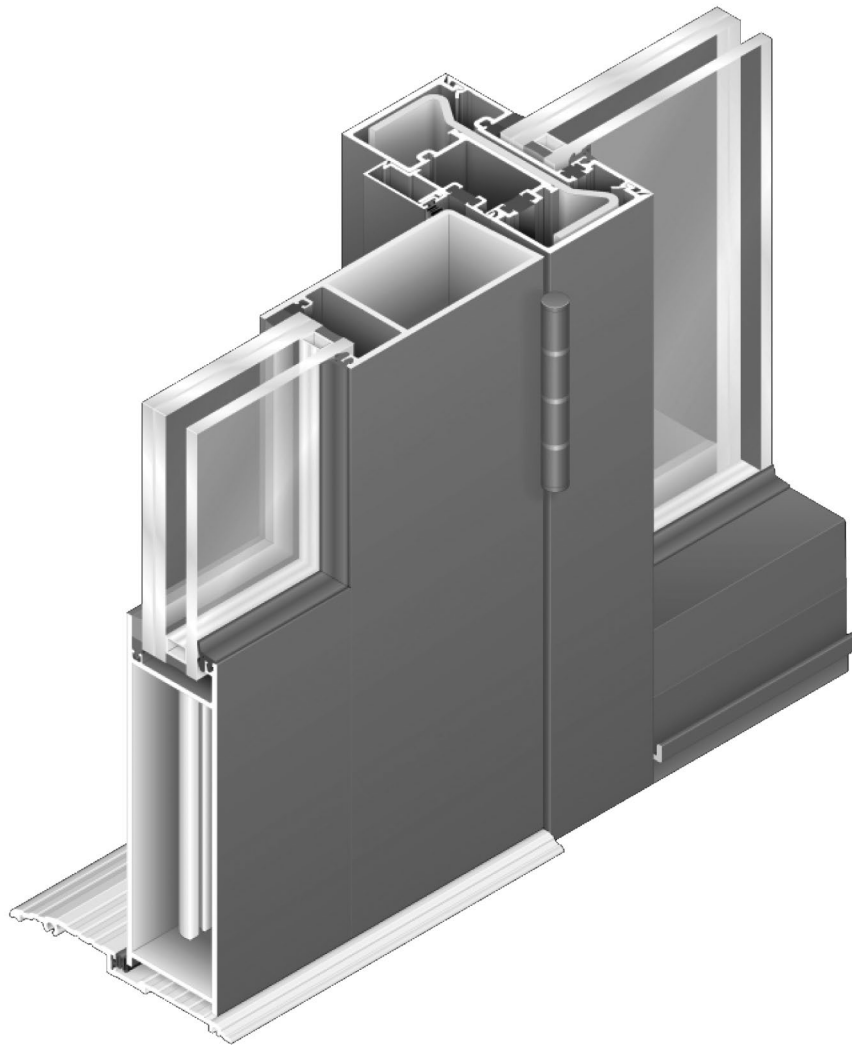

Phone: (800) 262-5151 • Fax: (866) 262-3299
crlaurence.com • usalum.com • crl-arch.com

HANDLING, STORAGE, AND PROTECTION OF ALUMINUM

The following precautions are recommended to protect the material against damage. Following these precautions will help ensure early acceptance of your products and workmanship.

A. HANDLE CAREFULLY.

All aluminum materials at job site must be stored in a safe place, well removed from possible damage by other trades. Cardboard wrapped or paper interleaved materials must be kept dry.

B. CHECK ARRIVING MATERIALS.

Check for quantities and keep records of where various materials are stored.

C. KEEP MATERIALS AWAY FROM WATER, MUD, AND SPRAY.

Prevent cement plaster or other materials from damaging the finish.

D. PROTECT THE MATERIALS AFTER ERECTION.

Protect erected frame with polyethylene or canvas splatter screen. Cement, plaster, terrazzo, other alkaline solutions, and acid based materials used to clean masonry are harmful to the finish. ***If any of these materials come in contact with the aluminum, immediately remove with water and mild soap.***

The rapidly changing technology within the architectural aluminum products industry demands that U.S. Aluminum reserve the right to revise, discontinue or change any product line, specification or electronic media without prior written notice.

NOTE: Dimensions in parentheses () are millimeters unless otherwise noted.

GENERAL INSTALLATION NOTES

Recommended guidelines for all installations:

- 1. REVIEW CONTRACT DOCUMENTS.** Check shop drawings, installation instructions, architectural drawings, and shipping lists to become thoroughly familiar with the project. The shop drawings take precedence and include specific details for the project. Note any **field verified** notes on the shop drawings prior to installing. The installation instructions are of a general nature and cover most conditions.
- 2. INSTALLATION.** All materials are to be installed plumb, level, and true.
- 3. BENCH MARKS.** All work should start from bench marks and/or column lines as established by the architectural drawings and the general contractor with guaranteed accuracy. Working from these datum points and lines determine:
 - a) The plane of the wall in reference to offset lines provided on each floor.
 - b) The finish floor lines in reference to bench marks on the outer building columns.
 - c) Mullion spacing from both ends of masonry opening to prevent dimensional build-up of daylight opening.
- 4. STEEL ANCHORS.** Steel anchors that weld to steel structure are normally line set before mullions are hung. Outstanding leg of anchors must be at 90° to offset lines. Mullion space should be held to $\pm 1/32"$ (0.8). Anchor clips vary per job conditions. Follow approved shop drawings for size and location of clips.
- 5. FIELD WELDING.** All field welding must be adequately shielded to avoid any splatter on glass or aluminum. Results will be unsightly and/or structurally unsound. Advise general contractor and other trades accordingly. All field welds of steel anchors must receive touch-up paint (zinc chromate) to avoid rust.
- 6. SURROUNDING CONDITIONS.** Make certain that construction which will receive your materials is in accordance with the contract documents. If not, notify the general contractor in writing and resolve differences before proceeding with work.
- 7. ISOLATION OF ALUMINUM.** Aluminum to be placed in direct contact with uncured masonry or incompatible materials should be isolated with a heavy coat of zinc chromate or bituminous paint.
- 8. SEALANTS.** Sealants must be compatible with all materials with which they have contact, including other sealant surfaces. Consult with sealant manufacturer for recommendations relative to joint size, shelf life, compatibility, cleaning/priming, tooling, adhesion, etc. Due to varying job conditions, all sealants used should be approved by sealant manufacturer to ensure that they will function for conditions shown on shop drawings.
- 9. FASTENING.** Within the body of these instructions "fastening" means any method of securing one part to another or to adjacent materials. Only those fasteners used within the system are specified in these instructions. Due to the varying perimeter conditions and performance requirements, perimeter and anchor fasteners are not specified in these instructions. For perimeter and anchor fasteners refer to the shop drawings or consult the fastener supplier.
- 10. BUILDING CODES.** Due to the diversity in state/provincial, local, and federal laws and codes that govern the design and application of architectural products, it is the responsibility of the individual architect, owner, and installer to assure that products selected for use on projects comply with all the applicable building codes and laws. U.S. Aluminum exercises no control over the use or application of its products, glazing materials, and operating hardware, and assumes no responsibility thereof.
- 11. EXPANSION JOINTS.** Expansion joints and perimeter seals shown in these instructions and in the shop drawings are shown at normal size. Actual dimensions may vary due to perimeter conditions and/or difference in metal temperature between the time of fabrication and the time of installation. Gap between expansion members should be based on temperature at time of installation.
- 12. WATER HOSE TEST.** As soon as a representative amount of the wall has been glazed (500 square feet or 46.5m²) a water hose test should be conducted in accordance with AAMA 501.2 specifications to check the installation. On all jobs the hose test should be repeated every 500 square feet (46.5m²) during the glazing operation.
- 13. COORDINATION WITH OTHER TRADES.** Coordinate with the general contractor any sequence with other trades which offset curtain wall installation (i.e. fire proofing, back-up walls, partitions, ceilings, mechanical ducts, converters, etc.).
- 14. CARE AND MAINTENANCE.** Final cleaning of exposed aluminum surfaces should be done in accordance with AAMA 609.1 for anodized aluminum and 610.1 for painted aluminum.
- 15. JOB SITE ESSENTIALS.** See pages 21 and 22.

FRAME FABRICATION

1. Measure rough opening to determine frame width and height dimension. Measure rough opening vertically in multiple places to determine shortest dimension. Allow a maximum of 1/2" (12.7) caulk space at head and jambs. See approved shop drawings for all other caulk space allowances. Shim subsill as required for leveling.

2. Cut members to length:

Subsill length is determined by entrance locations. Subsill butts to door jambs. Determine last bay installation and allow 1/8" (3.2) additional length to subsill. **See DETAIL A and B.**

Subsill length without entrance = Frame Dimension plus 1/4" (6.4). Subsill must extend 1/8" outside last wall jamb to allow last bay installation. Subsill runs through. **See DETAIL B.**

Vertical length = Frame Dimension minus 5/8" (15.9).
 Horizontal length = Daylight Opening.
 Glass stop length = Daylight Opening minus 1/32" (0.8).

DETAIL A
Frames With Entrance

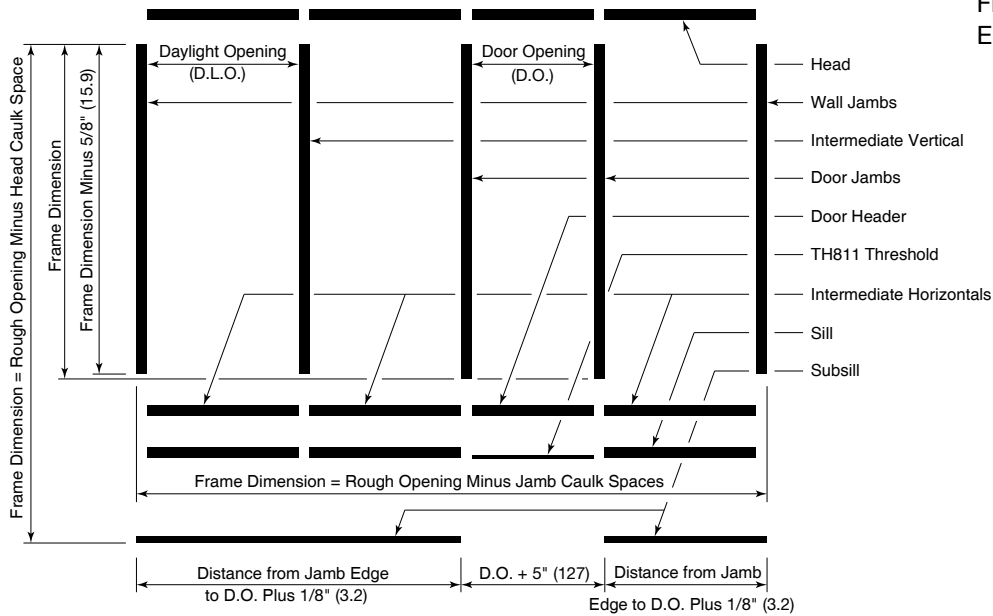

DETAIL B
Frames Without Entrance

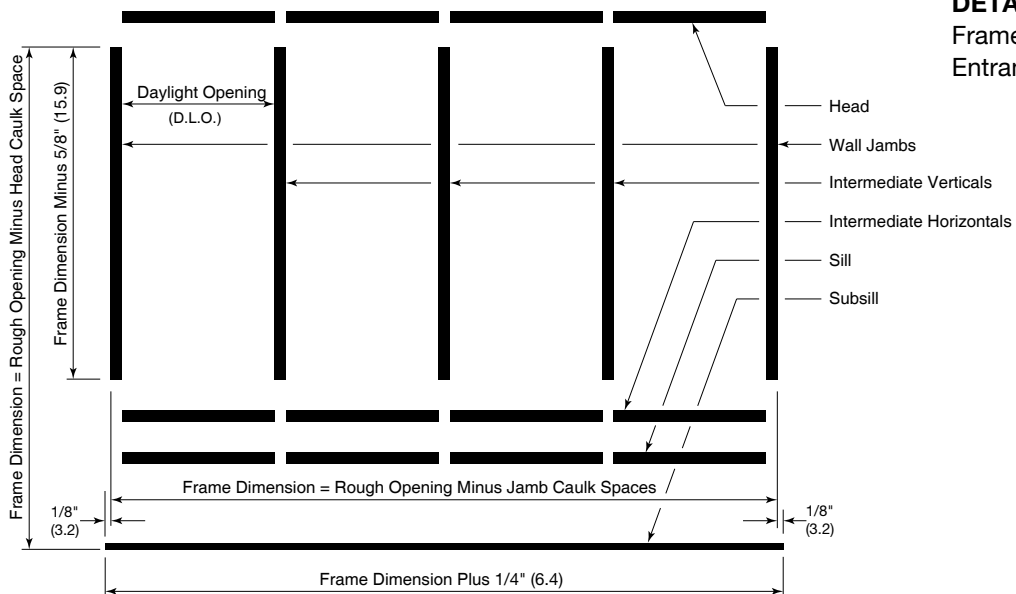

FABRICATION

3. Fabricate subsills for weep holes as shown in **DETAIL C**.
4. Drill end dam attachment holes as shown in **DETAIL C**. **NOTE:** End dams occur at wall jambs only.

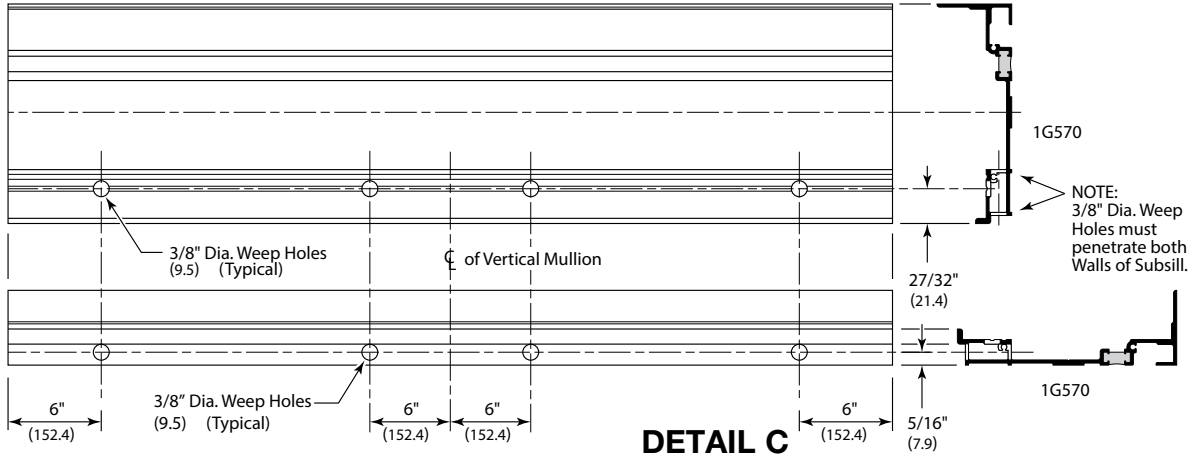

5. Fabricate subsills for anchor holes. **DETAIL D** shows base hole patterns. Final anchoring bolt types, spacings and fabrication are to be project determined and supersede these instructions. **See note below.**

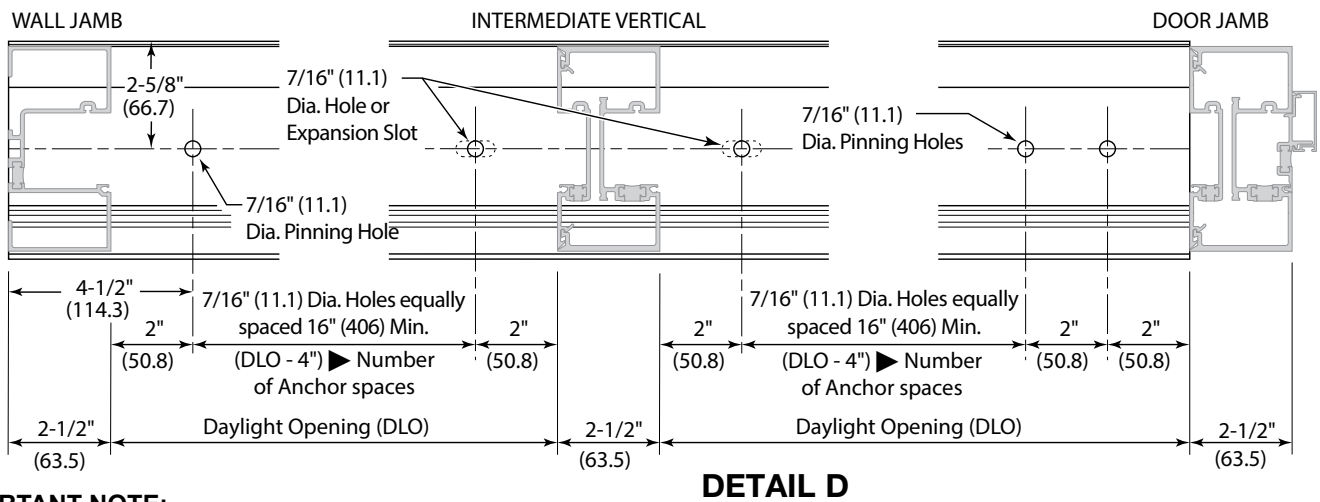

IMPORTANT NOTE:

Subsills exceeding 24' in length must provide for thermal expansion. Pin fixed locations to direct expansion movement away from entrance doors and wall jambs as shown in **DETAIL E**. Locations shown only illustrate anchor pattern types at each mullion and does **not** show anchor locations required between mullion spans. (16" max. typical)

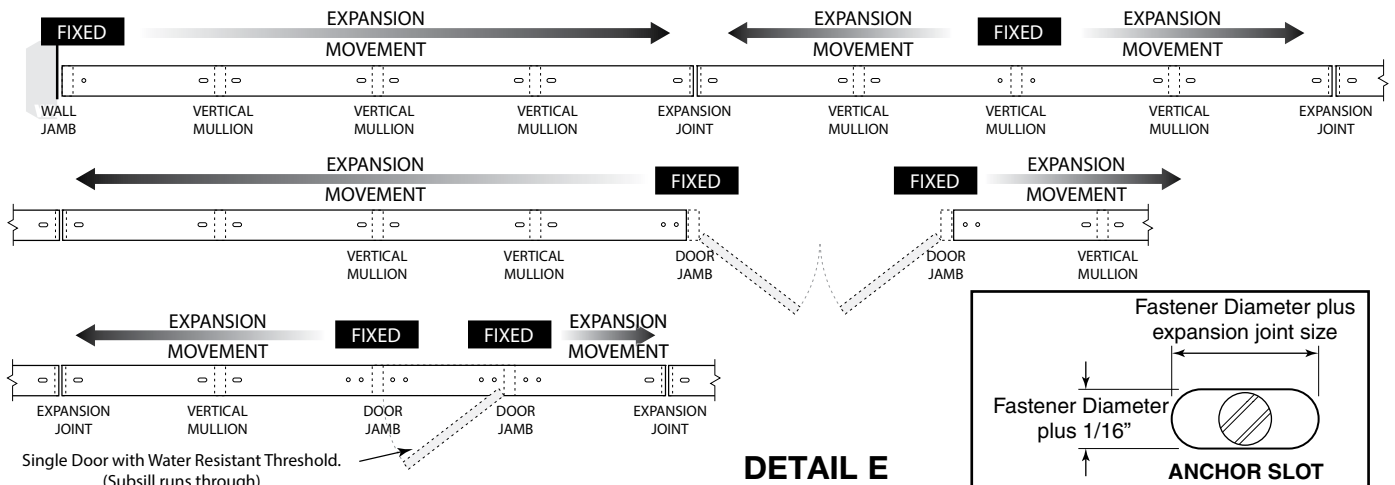

FABRICATION

6. Fabricate vertical members for horizontal attachment. Drill attachment and access holes as shown in **DETAILS F and G**.
NOTE: Details shown with deep pocket right orientation.

NOTE: Door frame members are sold pre-fabricated per project door schedule and approved shop drawings.

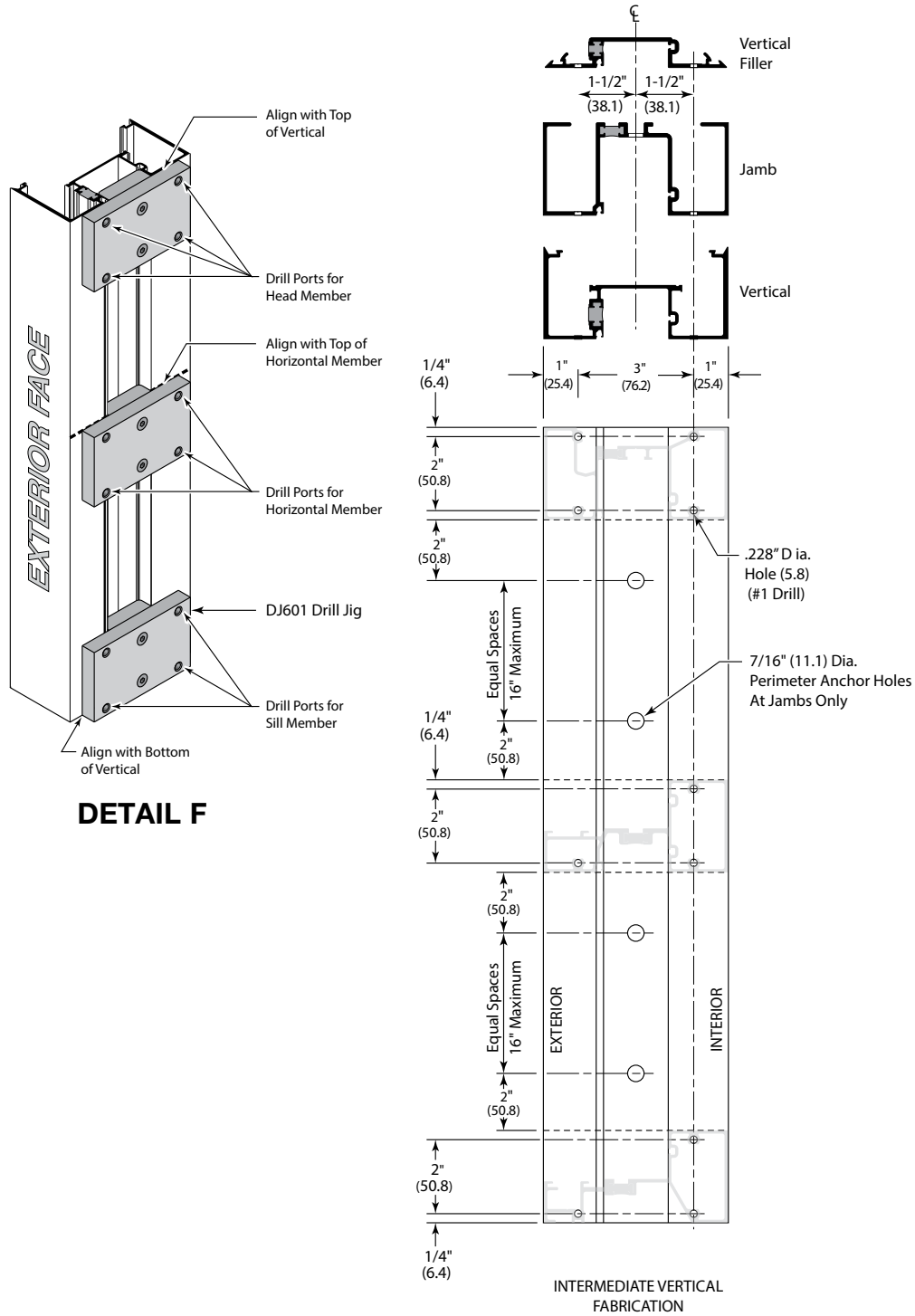

DETAIL F

DETAIL G

FABRICATION

7. Fabricate head and sill members for anchor and weep holes as shown in **DETAIL H**.

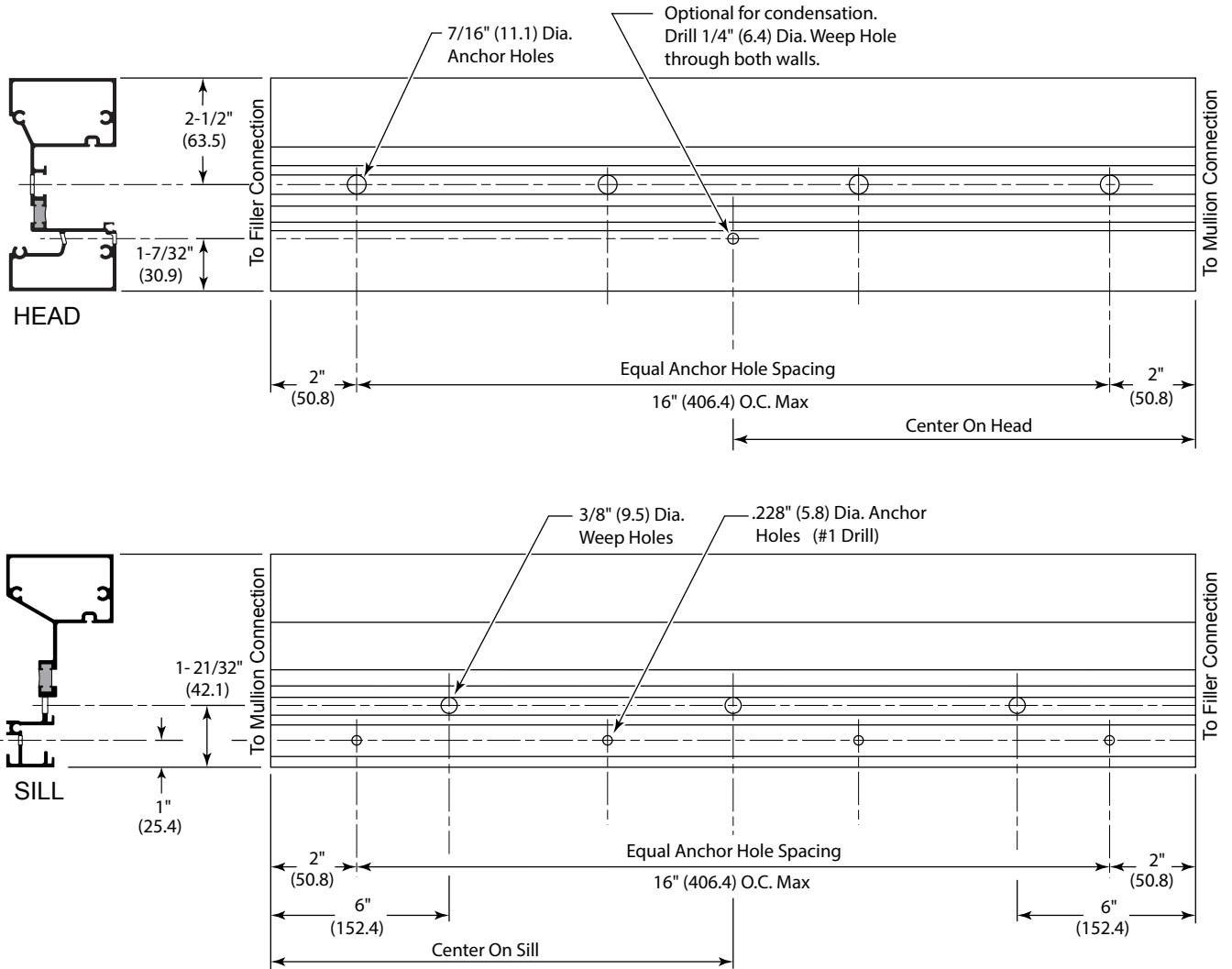

DETAIL H

8. Clean ends of subsills that are to receive end dams. Clean end dams, apply CRL RTV408 Sealant and install to ends of subsill as shown in **DETAIL I**.

CRITICAL NOTE:
Clean all contact surfaces with adequate solvent type and wipe with a lint free cloth using the 3 cloth cleaning method.

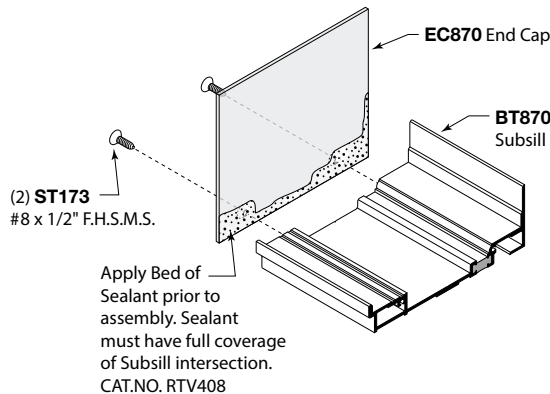

NOTE: Consult sealant Manufacturer for proper cleaning and priming recommendations.

DETAIL I

ASSEMBLY

1. Clean and apply Tremco Spectrum II or DOW 795 Silicone Sealant to ends of horizontals and thresholds. Attach horizontals to verticals using ST266 #12 x 1" H.W.H. SMS (Typ.) screws. See **DETAIL J**. Clean excess sealant from exposed joints.

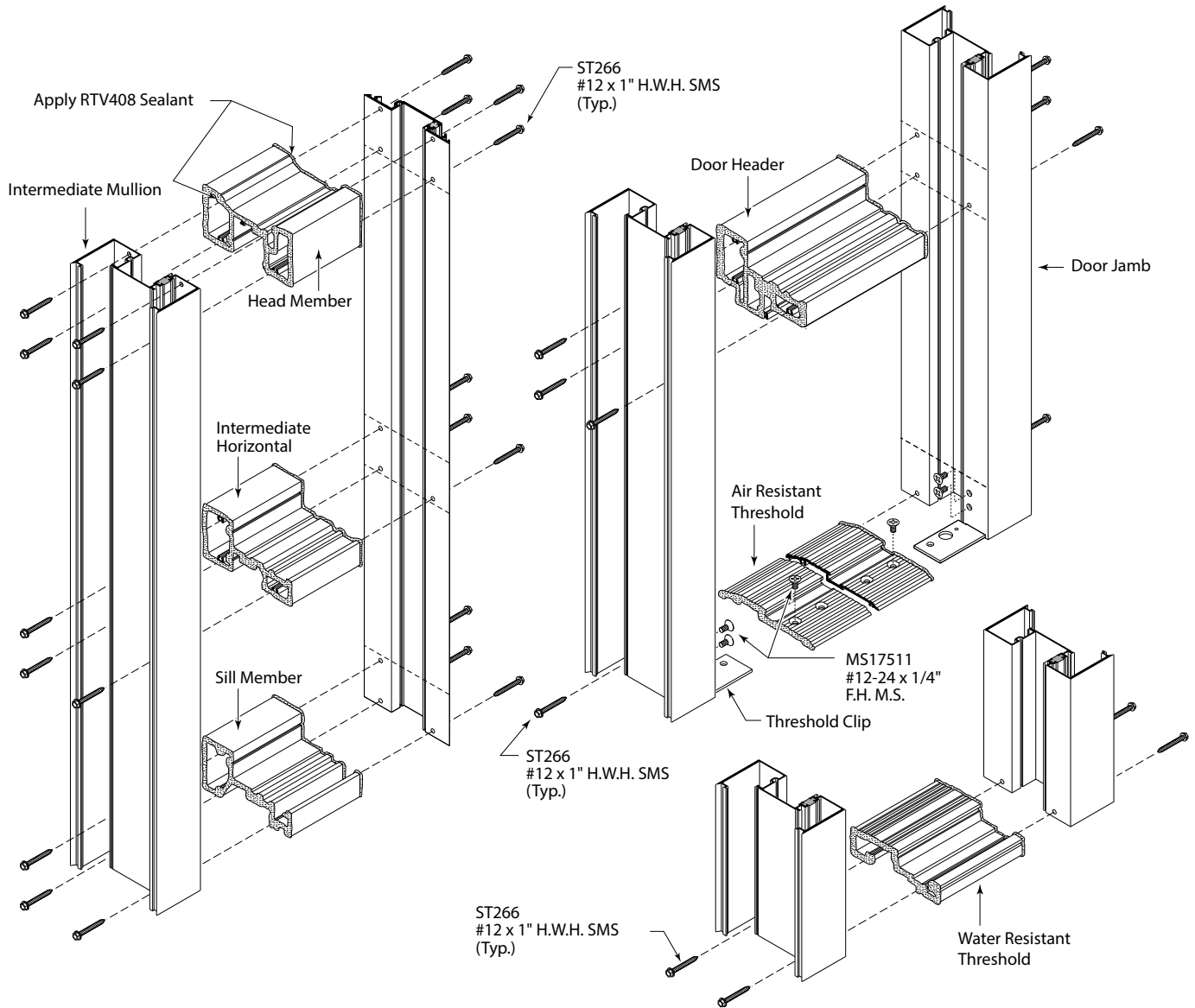

DETAIL J

NOTE: Consult sealant Manufacturer for proper cleaning and priming recommendations.

ASSEMBLY

2. Install water deflectors into vertical glass pockets at vertical/horizontal intersections as shown in **DETAIL K**. Install water deflectors into vertical member at head as shown in **DETAIL L**. Apply CRL RTV408 Silicone Sealant as shown.

Apply a CRL RTV408 Silicone Sealant to Interior Glass Pocket Wall prior to installing Water Deflector, making sure to fill the Spacer Reglet

Apply a bead of CRL RTV408 Sealant to Joining Pocket after Water Deflector is installed

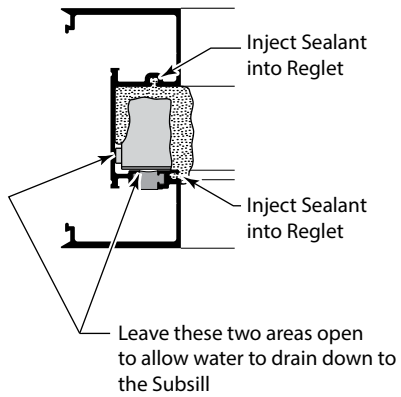
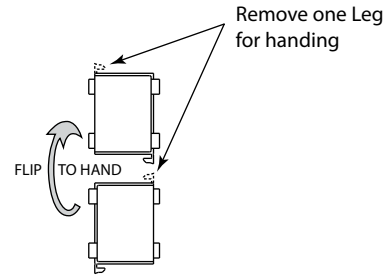
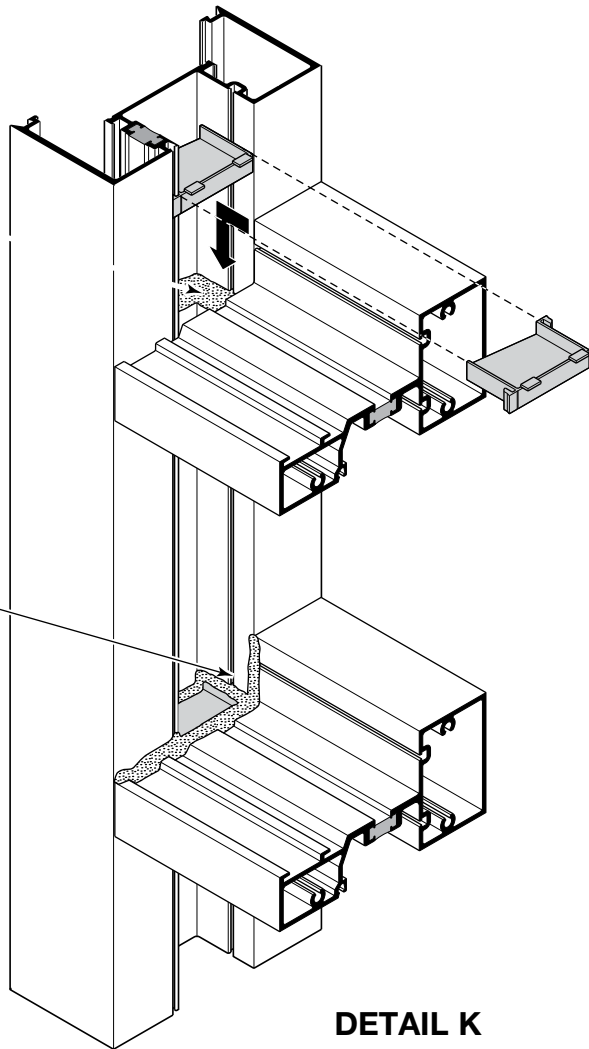

NOTE: Consult sealant Manufacturer for proper cleaning and priming recommendations.

DETAIL K

Apply Sealant to Interior Glass Pocket Wall prior to installing Water Deflector, making sure to fill the Spacer Reglet as shown in **DETAIL K**

Place Water Deflector into Glass Pocket and seal all Contact Edges CAT. NO. RTV408

Apply a bead of RTV408 Silicone Sealant to thoroughly seal Horizontal to Vertical Joint

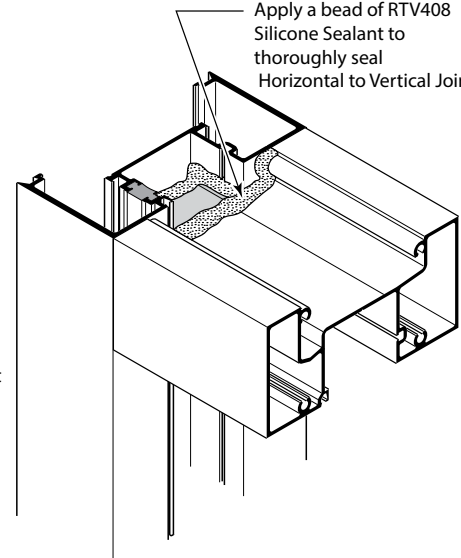
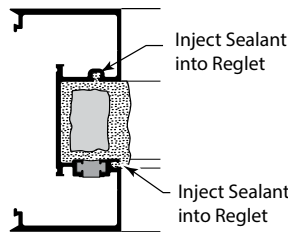
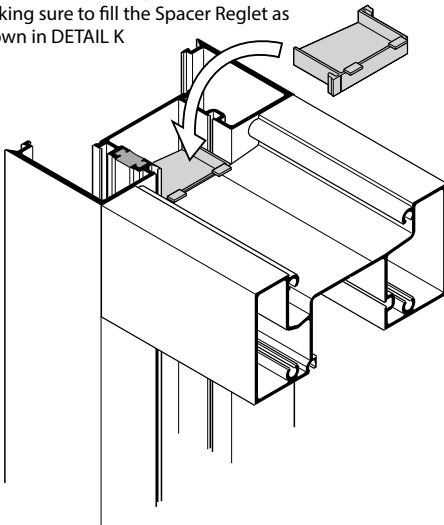

DETAIL L

ASSEMBLY

3. Prior to installing closure plates to tops of mullions, modify closure plates as shown in **DETAIL M**.
Note: Modification not required at jamb members.

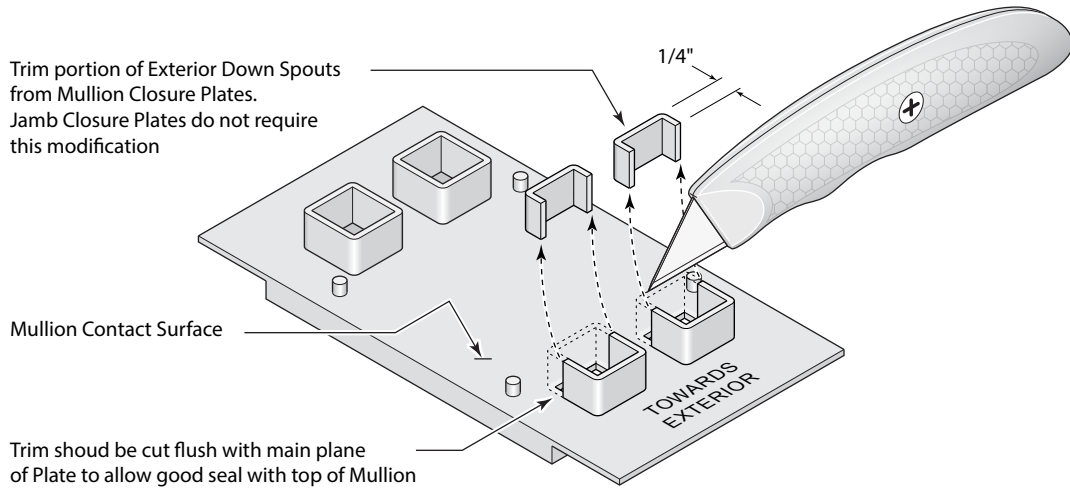

DETAIL M

4. Clean closure plates and top cut surface of mullions and jambs.
5. Apply CRL RTV408 Silicone Sealant to top of vertical member and press closure plate into place. **See DETAIL N.**

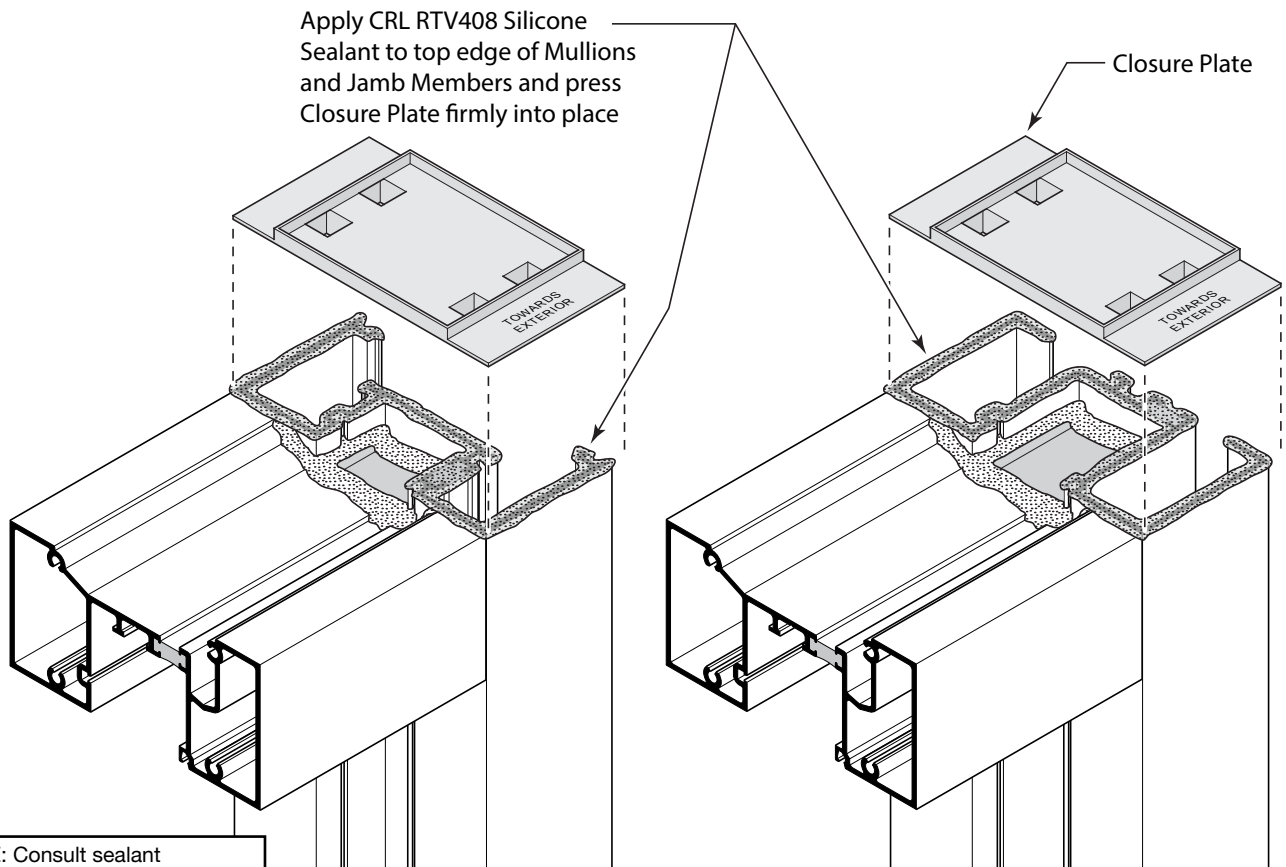

NOTE: Consult sealant Manufacturer for proper cleaning and priming recommendations.

DETAIL N

INSTALLATION

1. Install steel reinforcement. Slide steel into mullion as shown in **DETAIL O**.
NOTE: Steel position is CRITICAL at sill to allow access for sealing of door jamb base shown on **DETAIL Y** page 15.
2. Match drill through holes in steel reinforcement into mullion with #26 drill bit (.147" dia.). See **DETAIL O**.
3. Attach steel to mullion with ST238 #10 x 3/8", FH SMS. See **DETAIL P**.

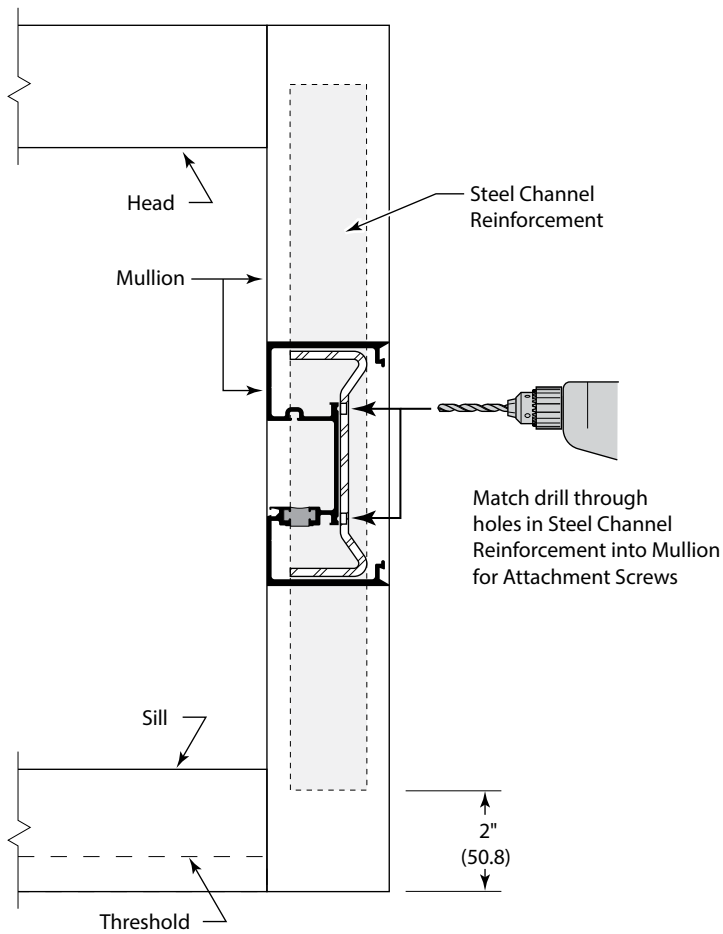

DETAIL O

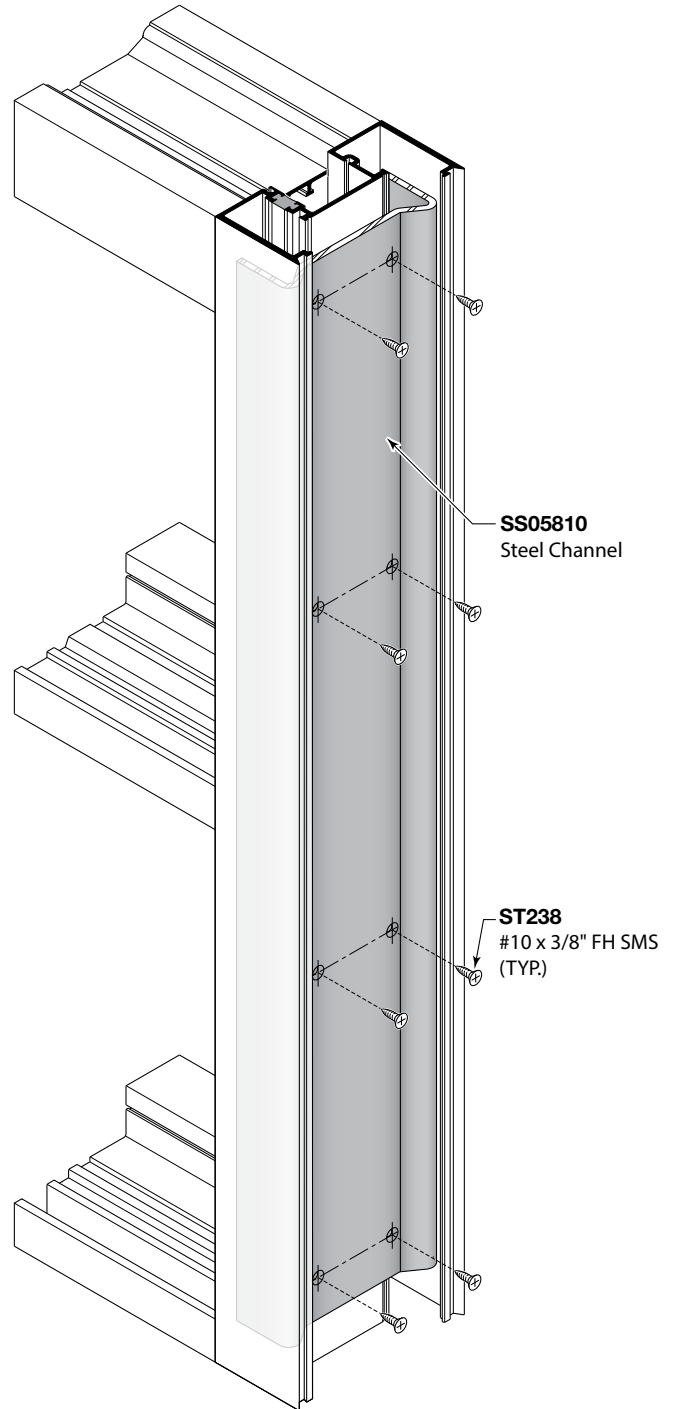

DETAIL P

INSTALLATION

- Place fabricated subsill into opening allowing for jamb shim space and door frame. Match drill anchor holes using subsill as template.
- Remove subsill, clean substratum. Apply full bed of sealant using CRL M64 or M66 across both ends and full length of interior subsill line. Run full bed of sealant across front area leaving a 3" (76) gap at each end as shown in **DETAIL Q**.

Note: Shim subsill as required for leveling. Coordinate shim space dimension with vertical member cut lengths.

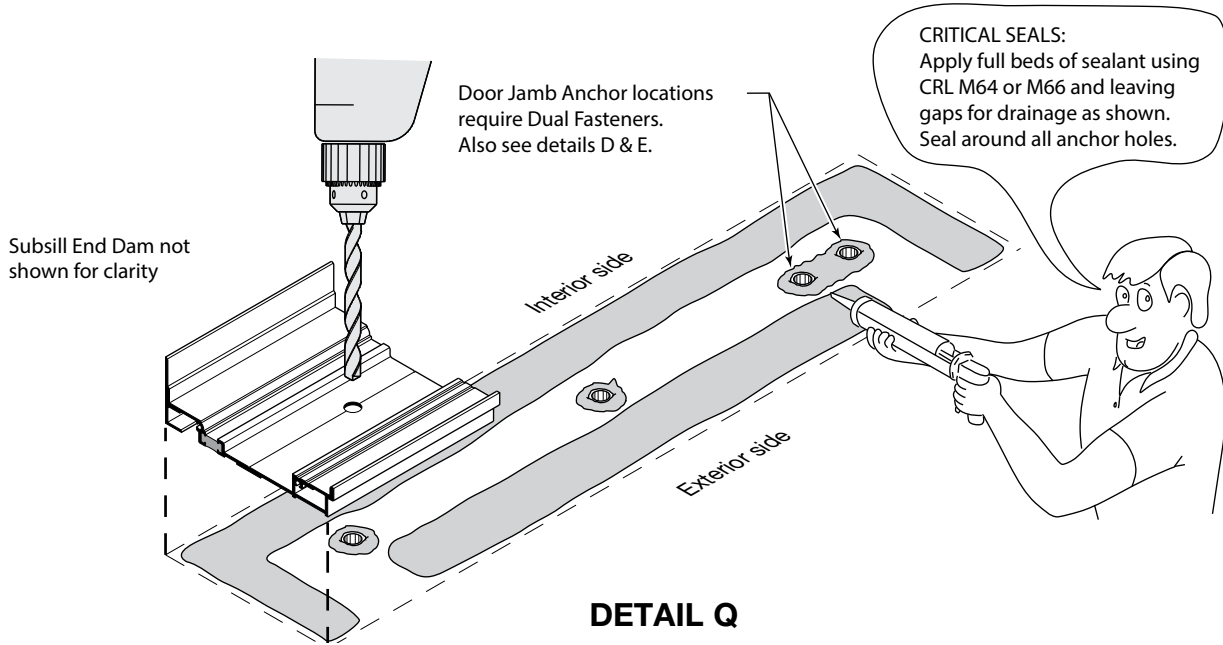

- Replace subsill into opening and anchor to substratum using required fasteners as described in approved shop drawings. Seal over all fastener heads with CRL33S as shown in **DETAIL R**.

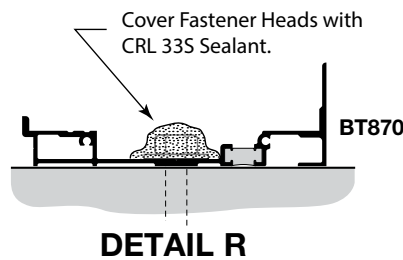

NOTE: Consult sealant Manufacturer for proper cleaning and priming recommendations.

- Subsill must be spliced for runs longer than 24' (731.5 cm). Apply CRL 827T34 3/4" (19.1) wide bond breaker tape across center of bottom side of splice sleeve as shown in **DETAIL S**.

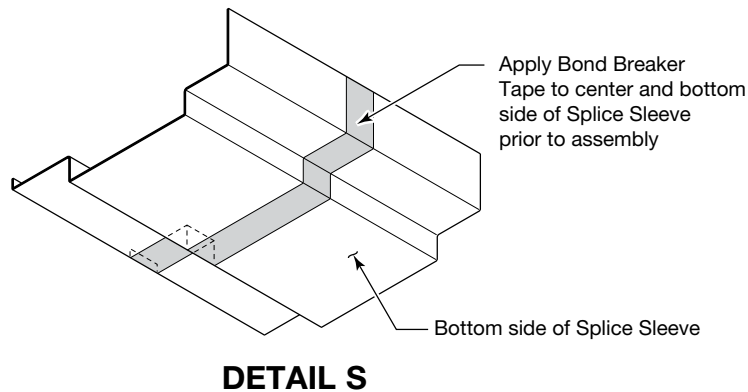

INSTALLATION

8. Insert backer rod into rectangular voids of subsill ends and seal with CRL 33S as shown in **DETAIL T**.

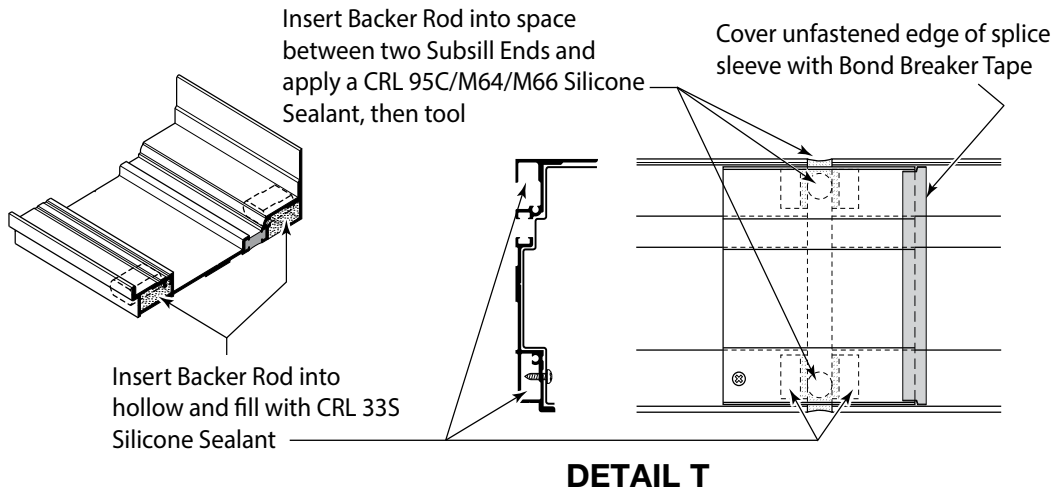

9. Attach one side of splice sleeve to subsill with ST206 #8 x 1/2" S.M.S. Apply Bond Breaker Tape to unfastened end of splice sleeve as shown. Seal over tape extending sealant 1/4" each side of tape edges as shown in **DETAIL U**. Seal all remaining sleeve edges as shown with CRL 95C/M64/M66 Sealant.

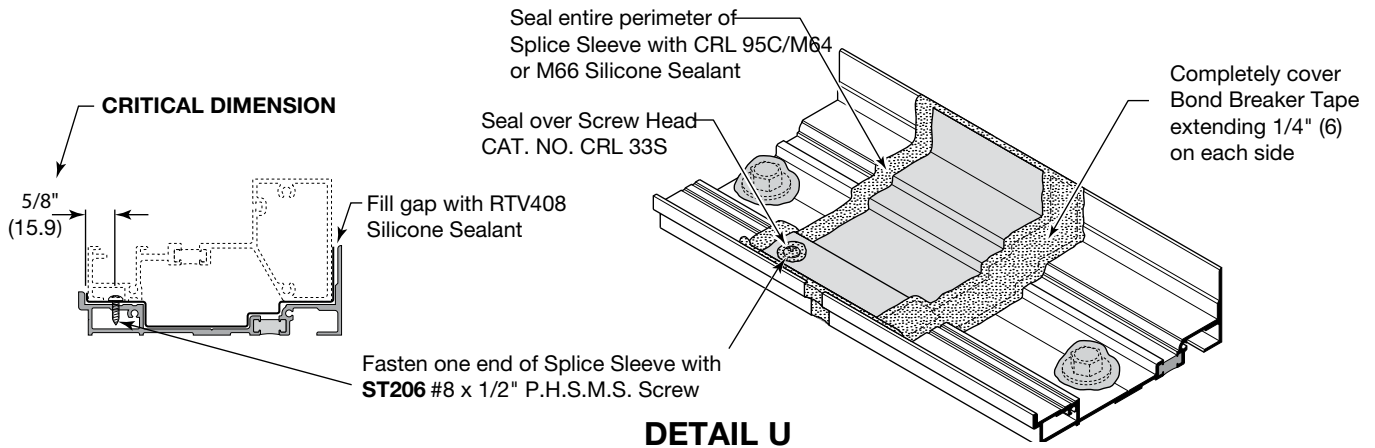

10. Prior to installing first and last frame panels, apply CRL 33S Silicone Sealant to subsill end dam joints and screw tips. Tool sealant. Shim between end dam and building. **See DETAIL V.**

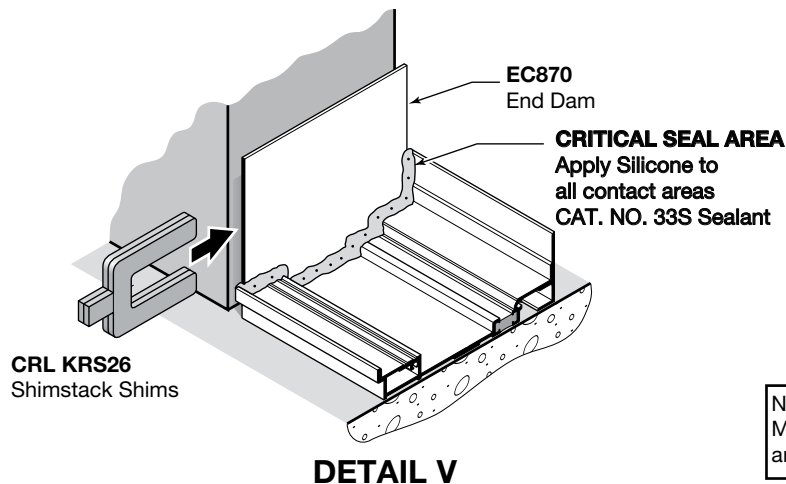

NOTE: Consult sealant Manufacturer for proper cleaning and priming recommendations.

INSTALLATION

11. Seal ends of subsill (**DETAIL W**) that but up to door jambs.

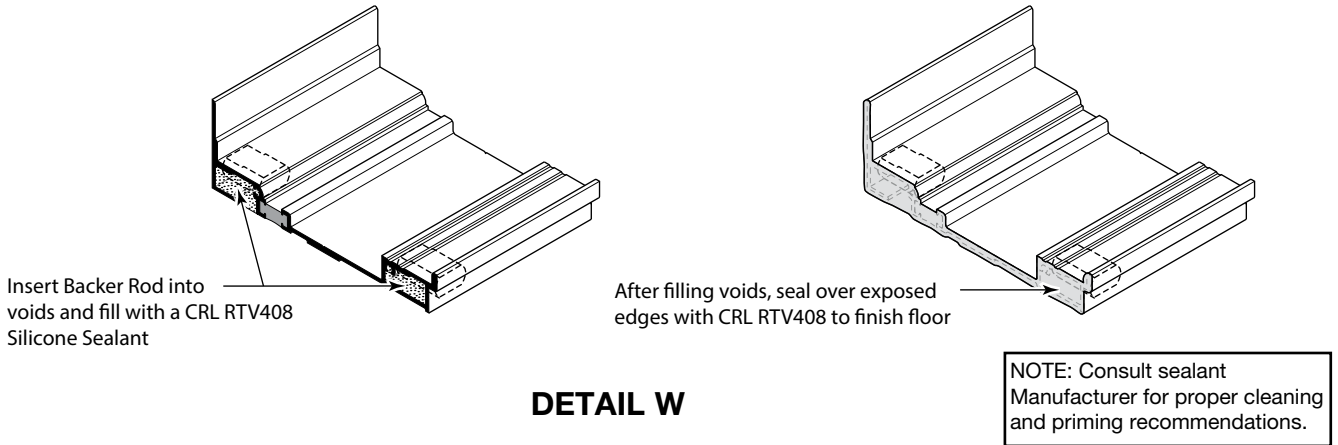

DETAIL W

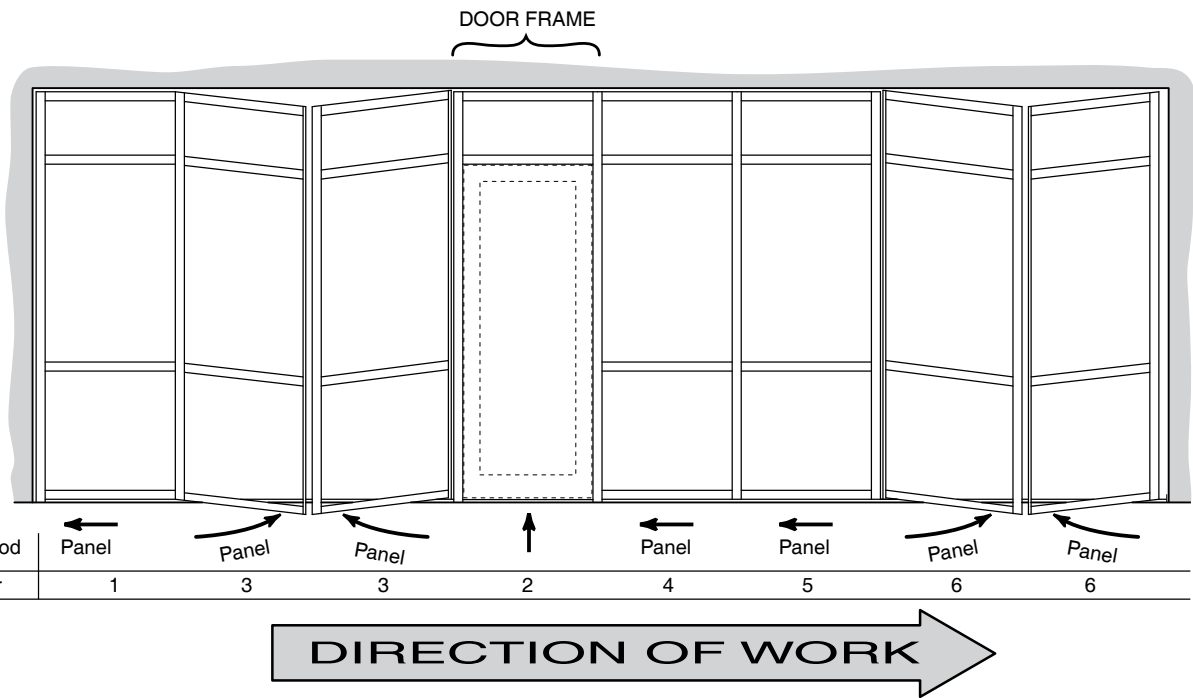

DETAIL X

INSTALLATION

12. Seal base of all installed door frame panel jambs and joining subsill edges prior to sidelight installation.
See **DETAIL Y**.

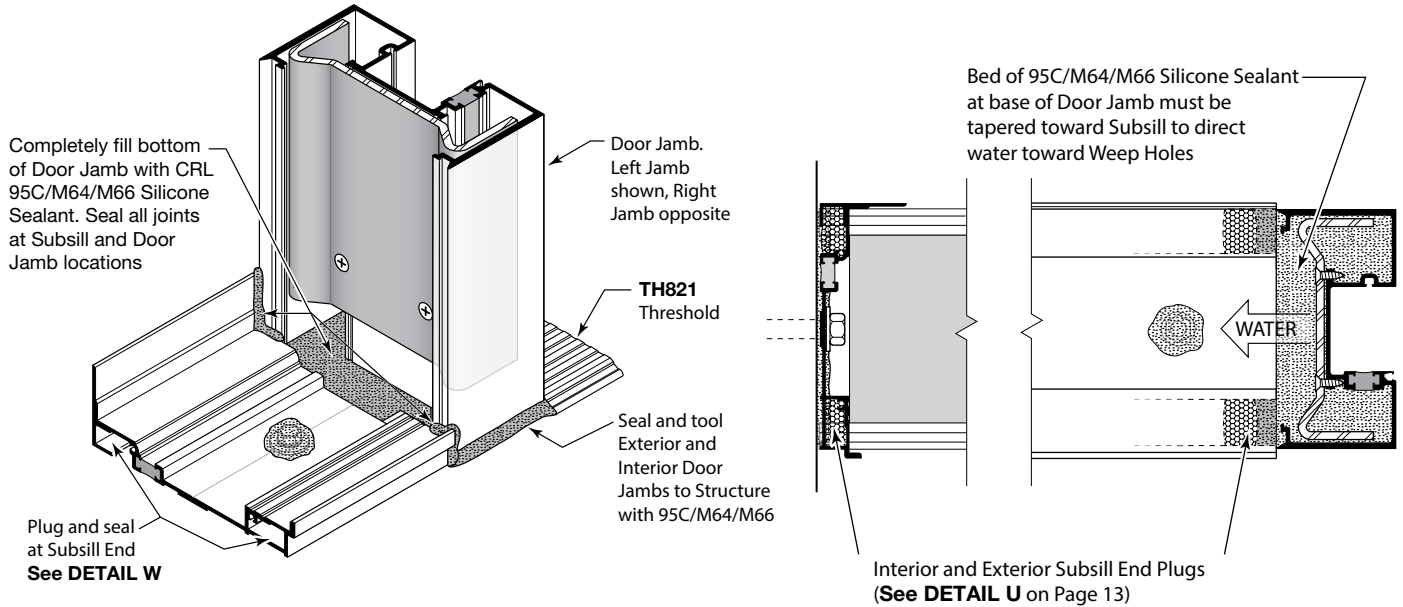

NOTE: These are **CRITICAL** seals. Sealant must form a water tight dam at base of door jamb.

DETAIL Y

13. Apply a continuous bead of Tremco Spectrum II or DOW 795 Silicone Sealant to interior and exterior snap legs as shown in **DETAIL Z**.

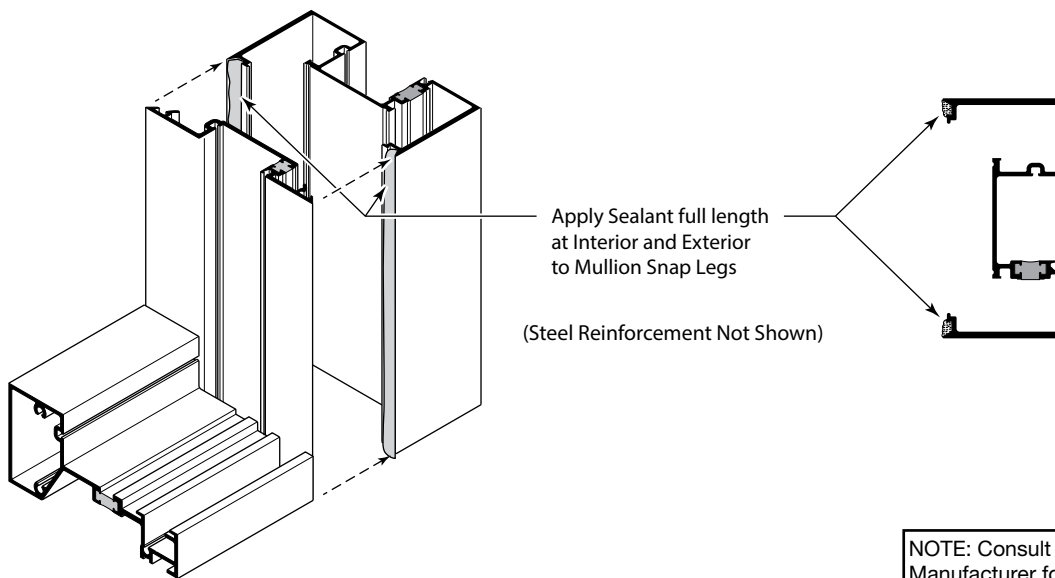

DETAIL Z

NOTE: Consult sealant Manufacturer for proper cleaning and priming recommendations.

INSTALLATION

14. Install assembled frame panels into opening starting at left jamb shimming for proper caulk spaces. Match drill through anchor holes in sill into subsill as shown in **DETAIL AA**. Attach sill to subsill with ST268 (#12 x 3/4" HWH SMS type B). Shim at anchor locations and fasten jamb and head member to building. Install next panels in left to right sequence anchoring each panel in place. Last bays and panels adjacent to installed door frame require "accordion" method to clear end dams and snap legs.
15. Seal over fastener heads at head members as shown in **DETAIL AA**.

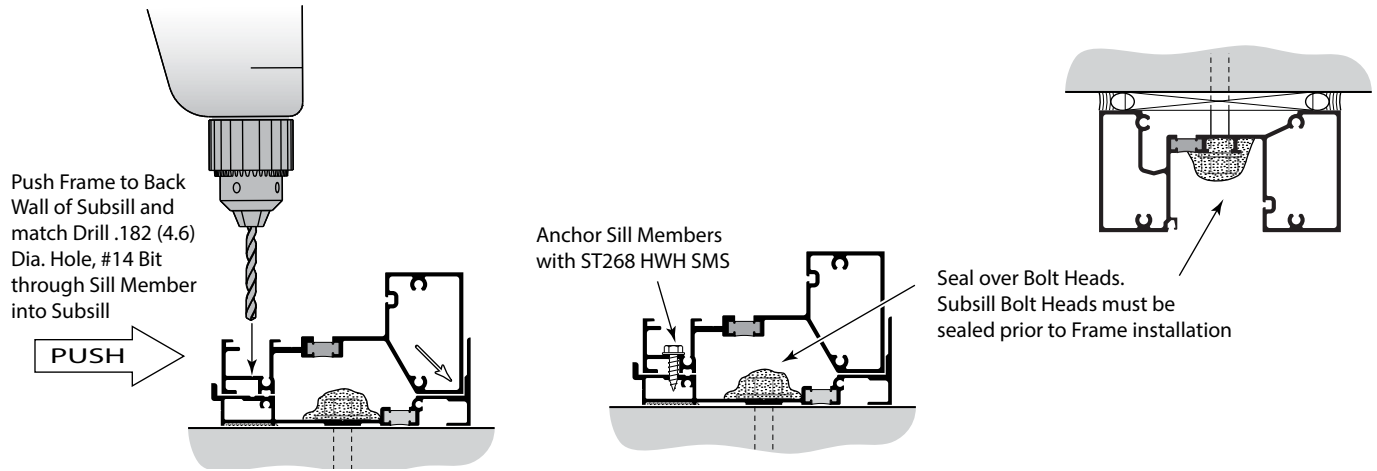

DETAIL AA

16. Install backer rod and apply Tremco Spectrum II or DOW 795 Silicone Sealant to interior and exterior frame perimeter at head and jambs.
17. Inject a bead of CRL 33S/RTV408 Silicone Sealant into exterior and interior reveals of subsill and sill members as shown in **DETAIL BB**.

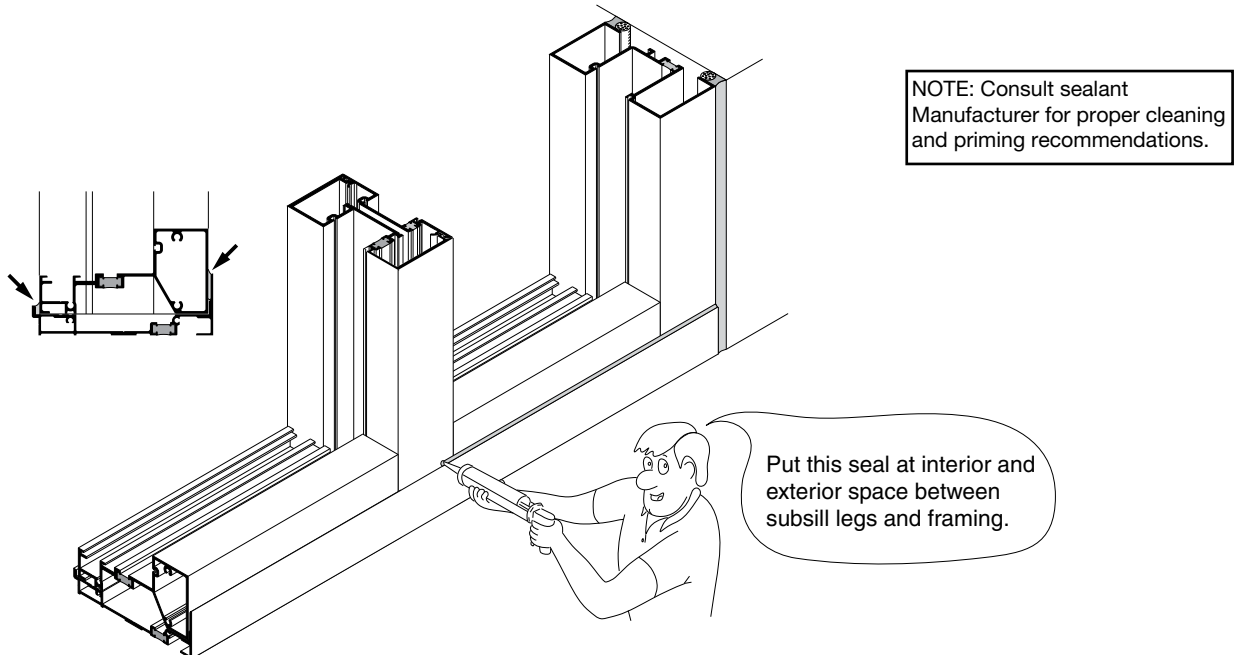

DETAIL BB

INSTALLATION

18. Lace gaskets into door stops, header and threshold leaving 1/8" (3.2) extension past each end to ensure a tight joint with connecting gaskets. Apply Tremco Spectrum II or DOW 795 Silicone Sealant to door stop adaptor and door stop as shown on **DETAIL CC**.
19. Attach door stop adaptors with ST197 #8 x 3/8" PH SMS 1" from each end and 12" O.C. and snap on door stops. Seal gasket intersections at head and threshold with CRL RTV408 Sealant. **See DETAIL CC.**

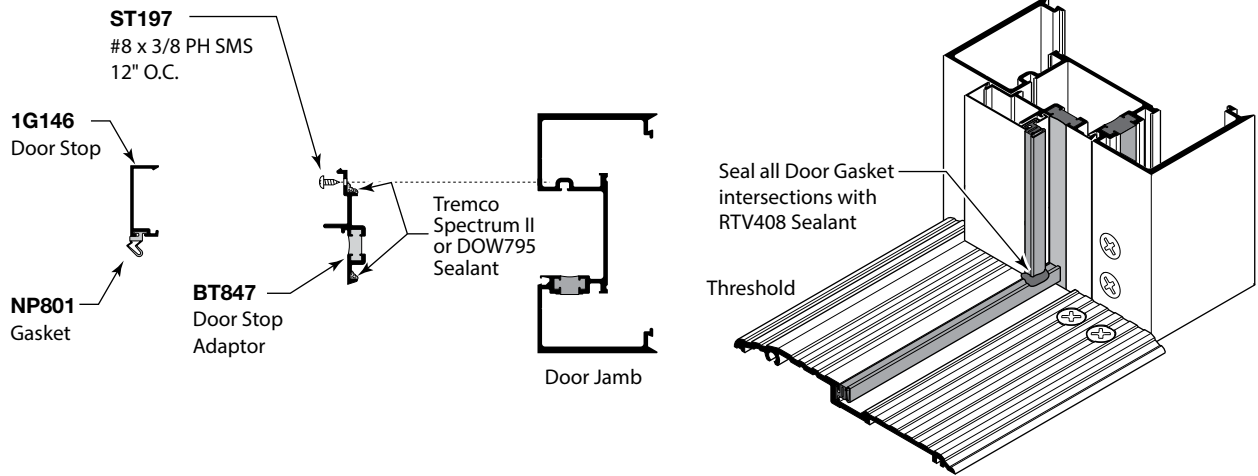

DETAIL CC

NOTE: Consult sealant Manufacturer for proper cleaning and priming recommendations.

GLAZING

1. Clean glazing areas of frames that will come in contact with *structural silicone.
2. Install spacer gaskets and setting blocks. Locate setting blocks at quarter points or as directed by approved shop drawings.
3. Clean surfaces of glass that will come in contact with *structural silicone.
DO NOT ALLOW CLEANING SOLUTION TO COME IN CONTACT WITH LAMINATE AT EDGE OF GLASS.
4. Install glass as shown in **DETAIL DD**. Center glass in opening. It is recommended to mark edges of glass to gauge proper glass bite. **PROPER GLASS BITE OF 9/16" (14.3) IS CRITICAL.**
5. Install glass stops and exterior gaskets.

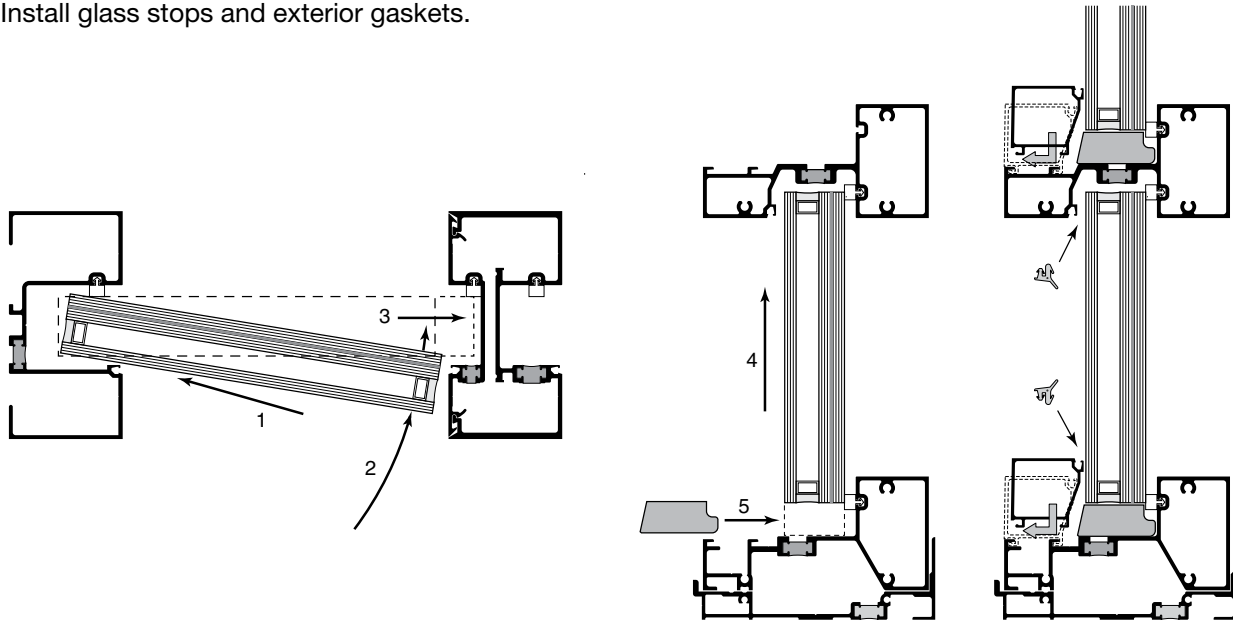

DETAIL DD

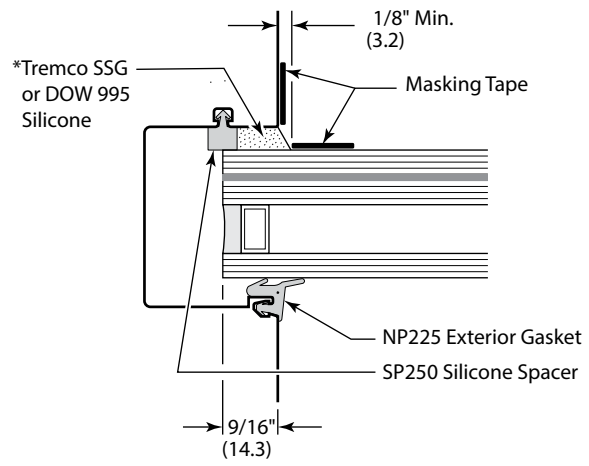
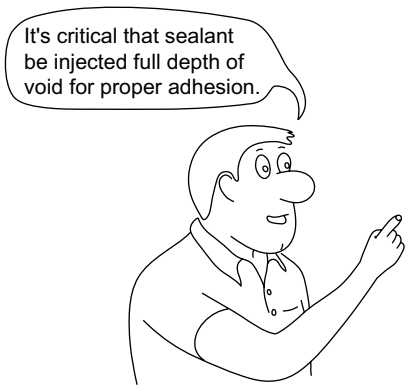

DETAIL EE

*NOTE: Refer to Sealant Section in General Installation Notes on page 03.

FABRICATION / INSTALLATION

NOTE: Water resistant threshold and threshold ramps are only available for single entrances. Door frames with TH800 thresholds require A.D.A. threshold ramps. The dimensions given are for reference only. Field measuring will be required to achieve proper miter joint alignment. Special consideration will be required for unlevel concrete conditions at entrance locations. Shimming under the small return end pieces may be required for proper leveling.

1. Cut pieces to length. See **DETAIL FF**.
2. Drill .221" (5.6) Dia. holes and countersink at .437" (11.1) Dia. x 82 degree for anchoring as shown. Anchor holes are shown with equal spacing and should not exceed 18" (457.2) O.C.

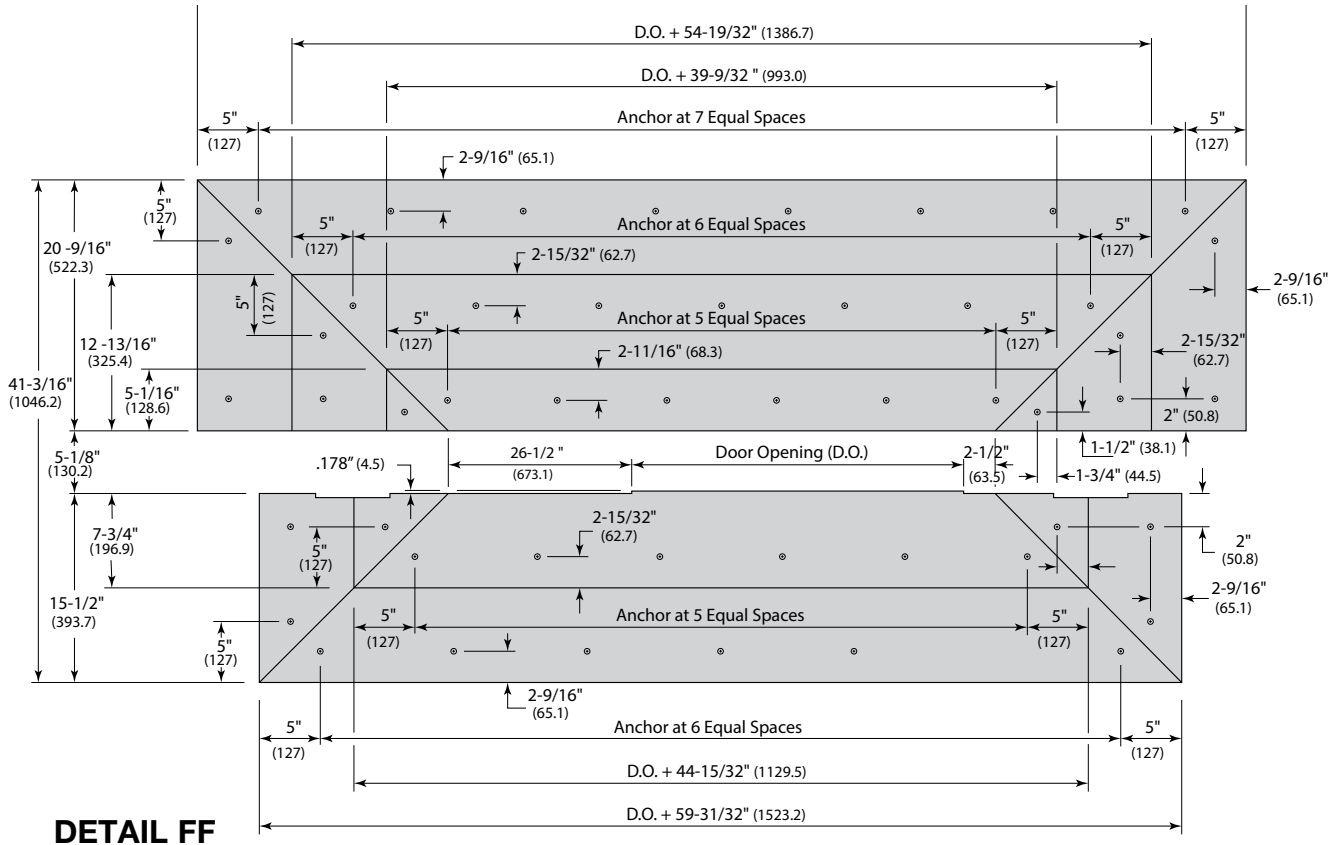

DETAIL FF

A.D.A. Note:
Ramps for single doors must extend 24" (609.6) beyond outside edge of lock jamb for approach access.
DETAIL GG shows hinge right layout with lock jamb to left.

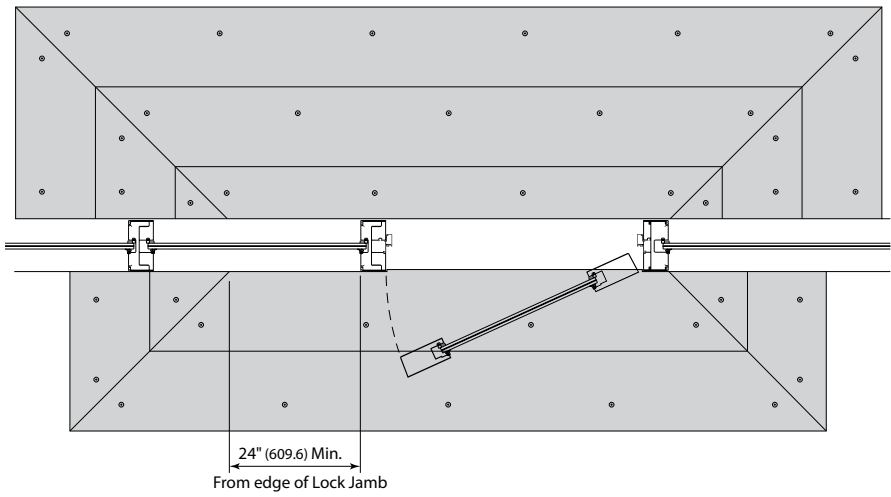

DETAIL GG

FABRICATION / INSTALLATION

3. Notch hook and exterior end pieces to clear frame components as shown in **Detail HH** and **II**.

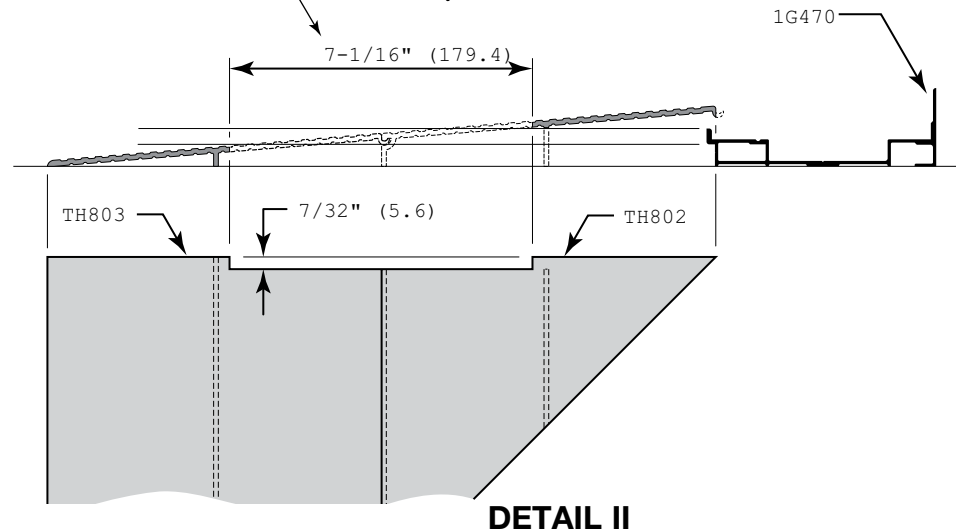
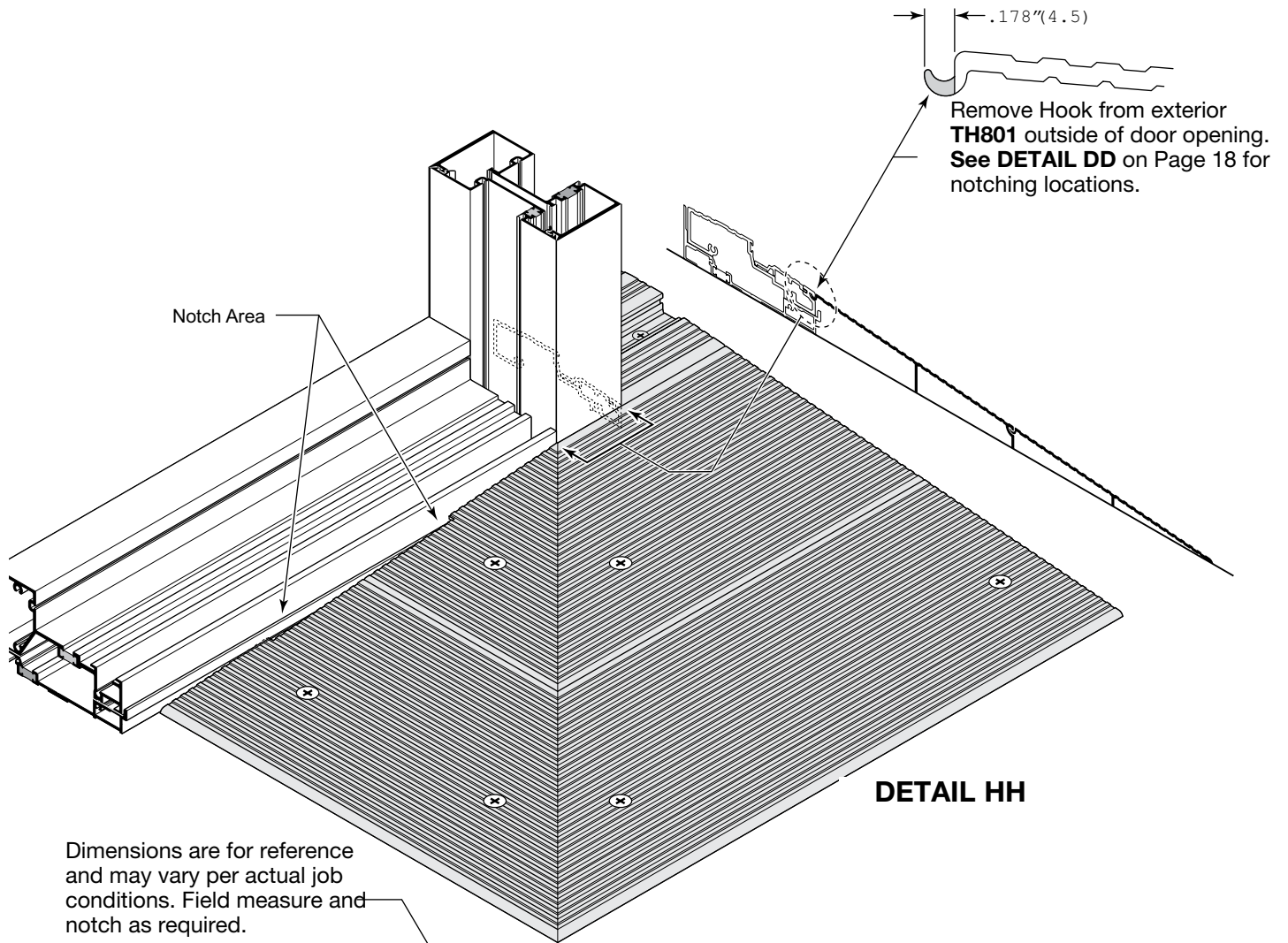



JOB SITE ESSENTIALS

Helpful Tools and Supplies for Installing CRL U.S. Aluminum Entrances, Storefronts, Windows, and Curtain Wall Systems



CRL 95C Silicone Building Sealant



CRL RTV408 Neutral Cure Silicone



CRL33S Silicone Sealant



CRL M64 Modified Smooth Polyurethane Construction Sealant



CRL M66 Modified Grainy Polyurethane Construction Sealant



**CRL12:1 Ratio Strap Frame Caulking Gun
CAT. NO. GA1203**



**CRL Complete Set of Seven All Stainless Steel Spatulas
CAT. NO. AB958G**



CRL Open Cell 5/8" Backer Rod



**CRL Backer Rod Roller Tool
CAT. NO. SBRR**

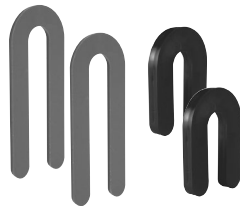

CRL PHS Series Plastic Horseshoe Shims



**CRL Hard Hat
CAT. NO. ES3452**



**CRL Digital Level Tool
CAT. NO. 406065**



**CRL Bond Breaker Tape
CAT. NO. 827T2**



**CRL Glass Cutter
CAT. NO. TC17B**



**CRL Running Pliers
CAT. NO. PPG1**



**CRL Sure-Grip 8" Vacuum Lifter
CAT. NO. S338**

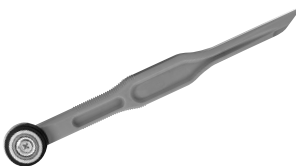

**CRL Gasket Roller
CAT. NO. VR10**

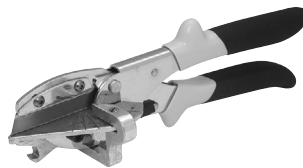

**CRL Gasket Cutter
CAT. NO. MC80N**



**CRL Glass Cleaner
CAT. NO. 1973**



**CRL Glass Wipes
CAT. NO. 1550**

SERIES IT600 HURRICANE RESISTANT STORMFRONT SYSTEM



**CRL Tape Measure
CAT. NO. 54125**

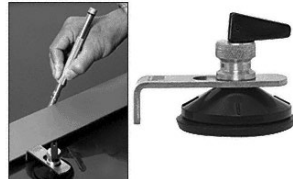

**CRL Glazier's Rule Holder
CAT. NO. RH670**

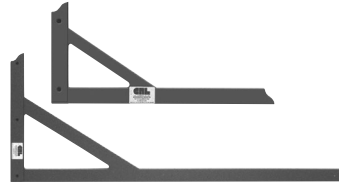

**CRL Phenolic L Square
CAT. NO. L48**



**CRL Spring Clamps
CAT. NO. JC3202HT**



**CRL Glass Marking Pencils
CAT. NO. GM44**



**CRL Belt Sander
CAT. NO. LD321**



**CRL Glass Grinding Belts
CAT. NO. CRL3X21120X**



**CRL All Terrain Dolly
CAT. NO. ATD1**



**CRL Gloves
CAT. NO. KF1TL**



**CRL Utility Knife
CAT. NO. K82**



**CRL Utility Knife Blades
CAT. NO. 1992C**



**CRL Cordless Driver/Drill
CAT. NO. LD147**



**CRL Cordless Screwdriver
CAT. NO. LD823**



**CRL Portable
10" Miter Saw
CAT. NO. LS1040**

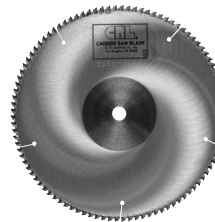

**CRL Nordic Carbide
Saw Blades
CAT. NO. CSB10X100AX**

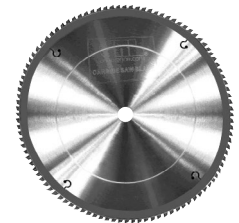

**CRL Cougar Carbide
Saw Blades
CAT. NO. CT10X100**



**CRL Soft-Face Power Hitter
CAT. NO. ST57532**



**CRL Portable Ladder
CAT. NO. 6206**



**CRL Door Jack
CAT. NO. DJ1**