

INSTALLATION INSTRUCTIONS

SERIES 4500 CURTAIN WALL

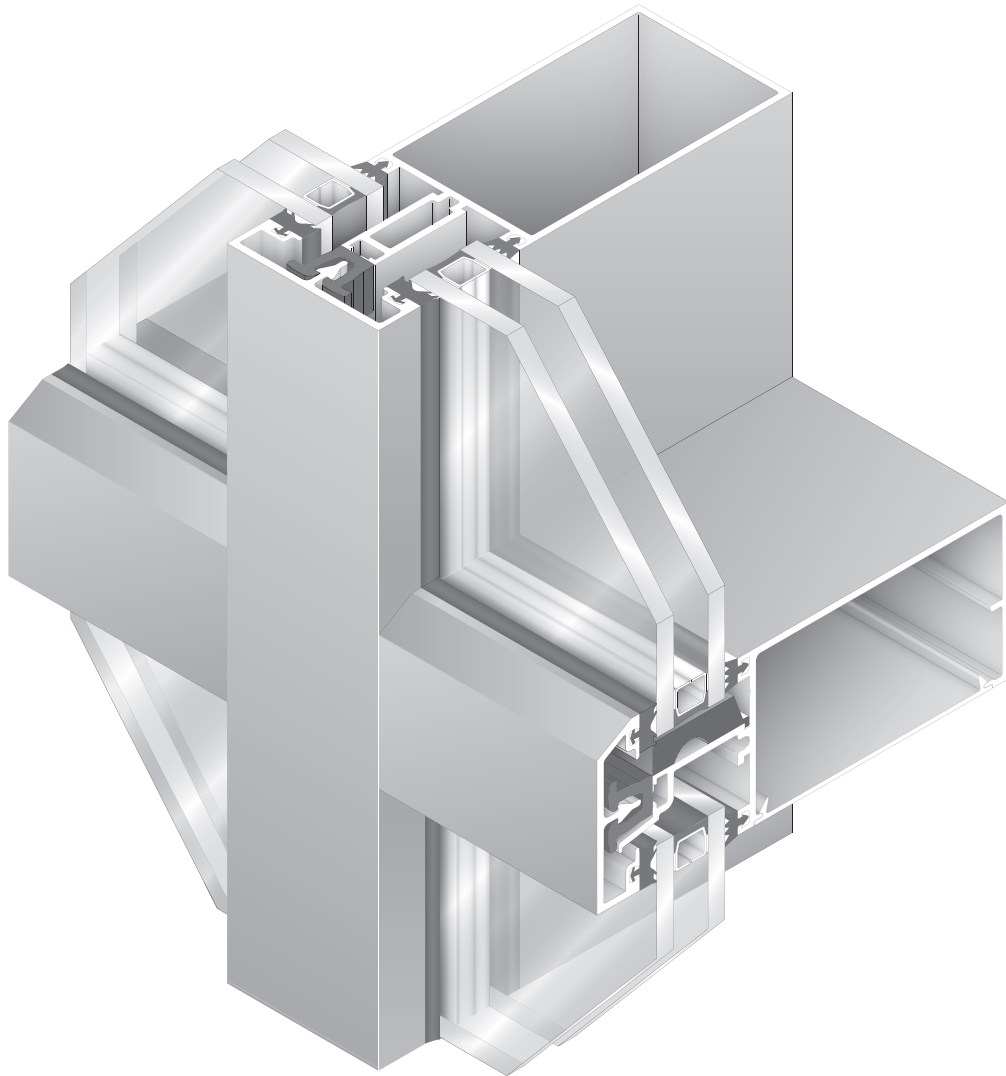

Phone: (800) 262-5151 • Fax: (866) 262-3299
crlaurence.com • usalum.com • crl-arch.com

HANDLING, STORAGE, AND PROTECTION OF ALUMINUM

The following precautions are recommended to protect the material against damage. Following these precautions will help ensure early acceptance of your products and workmanship.

A. HANDLE CAREFULLY.

All aluminum materials at job site must be stored in a safe place, well removed from possible damage by other trades. Cardboard wrapped or paper interleaved materials must be kept dry.

B. CHECK ARRIVING MATERIALS.

Check for quantity counts and keep records of where various materials are stored.

C. KEEP MATERIALS AWAY FROM WATER, MUD, AND SPRAY.

Prevent cement, plaster, or other materials from damaging the finish.

D. PROTECT THE MATERIALS AFTER ERECTION.

Protect erected frame with polyethylene or canvas splatter screen. Cement, plaster, terrazzo, other alkaline solutions, and acid based materials used to clean masonry are harmful to the finish. ***If any of these materials come in contact with the aluminum, immediately remove with water and mild soap.***

The rapidly changing technology within the architectural aluminum products industry demands that U.S. Aluminum reserve the right to revise, discontinue or change any product line, specification or electronic media without prior written notice.

NOTE: Dimensions in parentheses () are millimeters unless otherwise noted.

GENERAL INSTALLATION NOTES

RECOMMENDED GUIDELINES FOR ALL INSTALLATIONS:

- 1. REVIEW CONTRACT DOCUMENTS.** Check shop drawings, installation instructions, architectural drawings and shipping lists to become thoroughly familiar with the project. The shop drawings take precedence and include specific details for the project. Note any field verified notes on the shop drawings prior to installing. The installation instructions are of a general nature and cover most conditions.
- 2. INSTALLATION.** All materials are to be installed plumb, level, and true.
- 3. BENCH MARKS.** All work should start from bench marks and/or column lines as established by the architectural drawings and the general contractor with guaranteed accuracy. Working from these datum points and lines determine:
 - a) The plane of the wall in reference to offset lines provided on each floor.
 - b) The finish floor lines in reference to bench marks on the outer building columns.
 - c) Mullion spacing from both ends of masonry opening to prevent dimensional build-up of daylight opening.
- 4. FIELD WELDING.** All field welding must be adequately shielded to avoid any splatter on glass or aluminum. Results will be unsightly and/or structurally unsound. Advise general contractor and other trades accordingly. All field welds of steel anchors must receive touch-up paint (zinc chromate) to avoid rust.
- 5. SURROUNDING CONDITIONS.** Make certain that construction which will receive your materials is in accordance with the contract documents. If not, notify the general contractor in writing and resolve differences before proceeding with work.
- 6. ISOLATION OF ALUMINUM.** Aluminum to be placed in direct contact with uncured masonry or incompatible materials should be isolated with a heavy coat of zinc chromate or bituminous paint.
- 7. SEALANTS.** Sealants must be compatible with all materials with which they have contact with (full or incidental), including other sealant surfaces. It is the sole responsibility of the glass company to consult the sealant manufacturer for recommendations regarding joint size, shelf life, compatibility, cleaning, priming, tooling, adhesion, etc. It is the responsibility of the **Glazing Contractor** to submit a statement from the sealant manufacturer indicating that glass and glazing materials have been tested for compatibility and adhesion with glazing sealants, and interpreting test results relative to material performance, including recommendations for primers and substrate preparation required to obtain adhesion. The chemical compatibility of all glazing materials and framing sealants with each other and with like materials used in glass fabrication must be established. ***This is required on every project.***
- 8. FASTENING.** Within the body of these instructions "fastening" means any method of securing one part to another or to adjacent materials. Only those fasteners used within the system are specified in these instructions. Due to the varying perimeter conditions and performance requirements, perimeter and anchor fasteners are not specified in these instructions. For perimeter and anchor fasteners refer to the shop drawings or consult the fastener supplier.
- 9. BUILDING CODES.** Due to the diversity in state/provincial, local, and federal laws and codes that govern the design and application of architectural products, it is the responsibility of the individual architect, owner, and installer to assure that products selected for use on projects comply with all the applicable building codes and laws. U.S. Aluminum exercises no control over the use or application of its products, glazing materials, and operating hardware, and assumes no responsibility thereof.
- 10. EXPANSION JOINTS.** Expansion joints and perimeter seals shown in these instructions and in the shop drawings are shown at normal size. Actual dimensions may vary due to perimeter conditions and/or difference in metal temperature between the time of fabrication and the time of installation. Gaps between expansion members should be based on temperature at time of installation.
- 11. WATER HOSE TEST.** As soon as a representative amount of the wall has been glazed (500 square feet or 46.5 m²) a water hose test should be conducted in accordance with AAMA 502-08 specifications to check the installation. On all jobs the hose test should be repeated every 500 square feet (46.5 m²) during the glazing operation.
- 12. COORDINATION WITH OTHER TRADES.** Coordinate with the general contractor any sequence with other trades which offset curtain wall installation (i.e. fire proofing, back-up walls, partitions, ceilings, mechanical ducts, converters, etc.).
- 13. CARE AND MAINTENANCE.** Final cleaning of exposed aluminum surfaces should be done in accordance with AAMA 609.1 for anodized aluminum and 610.1 for painted aluminum.
- 14. JOB SITE ESSENTIALS.** See pages 30 and 31.

SHEAR BLOCK (STICK ERECTED) FABRICATION

The Series 4500 Curtain Wall Systems are designed for shear block (Stick erected) and screw spline (Panel erected) type assembly methods. The shear block method of assembly is recommended for multi-floor applications where mullions will be spliced. Illustrations used in these instructions depict the 5" (127) back members for 1" (25) glazing. All other back member depths are treated in a similar fashion unless otherwise noted.

1. Cut members to length.

Vertical Mullions, Face Covers and Adapters	Frame Height
Horizontal Members and Face Covers	Daylight Opening
Horizontal Snap-In Fillers	Daylight Opening minus 1/32" (0.8)
Vertical Transition Members	Daylight Opening plus 1-3/8" (34.9)
Horizontal Transition Members	Daylight Opening minus 1/16" (1.6)
Butt Glazed Horizontal Face Covers	Continuous
Butt Glazed Vertical Covers	Frame Height
Glass Retainer	3" (76.2) piece of face cover
Door Jamb Mullions	Length (+) plus bottom clearance

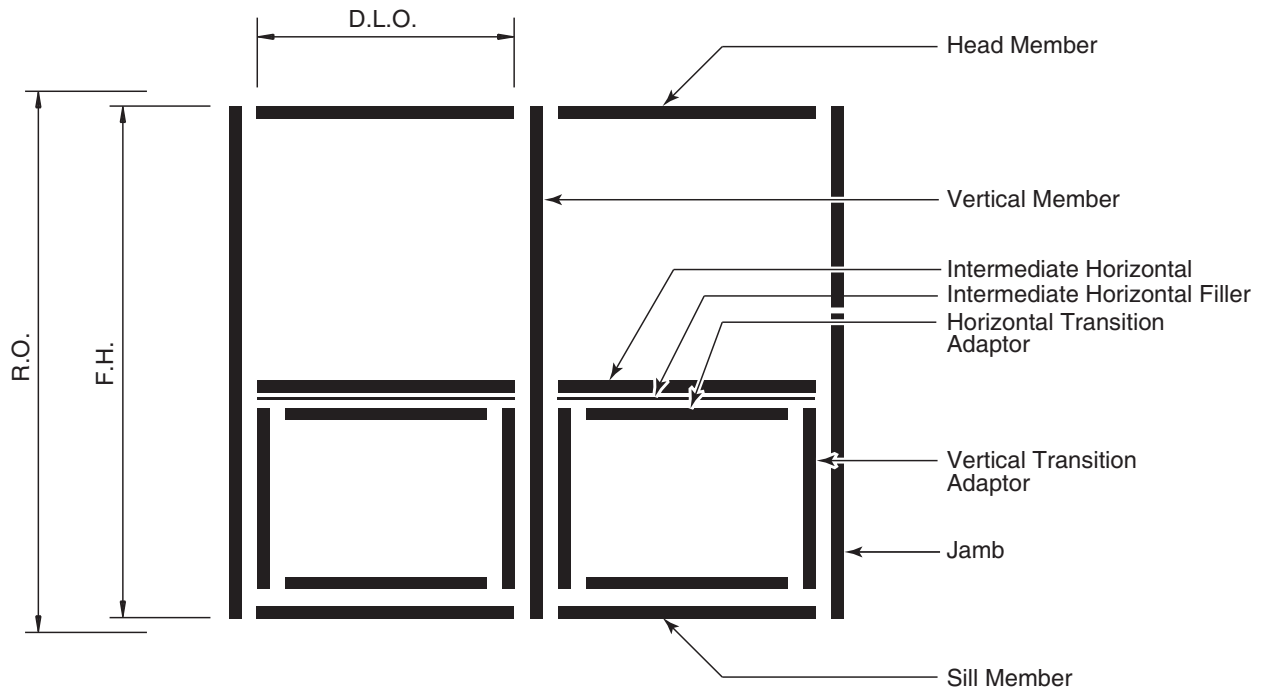

DETAIL A

NOT TO SCALE

SHEAR BLOCK (STICK ERECTED) FABRICATION

2. Fabricate vertical members to receive shear blocks as shown. Mark locations of horizontal members. Use Cat. No. **DJ750** Drill Jig.

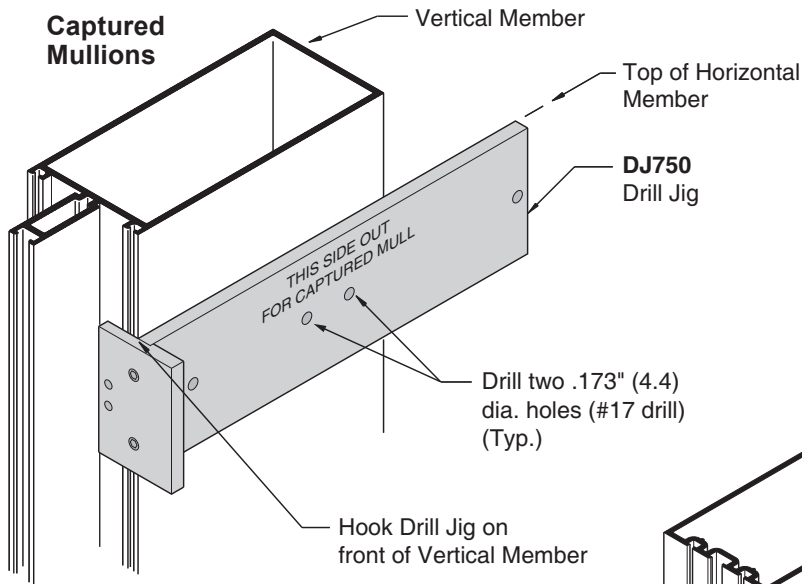

Silicone Mullions

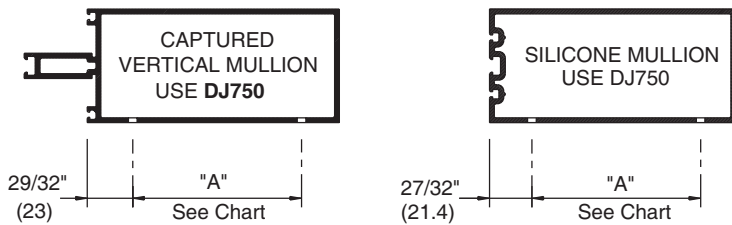
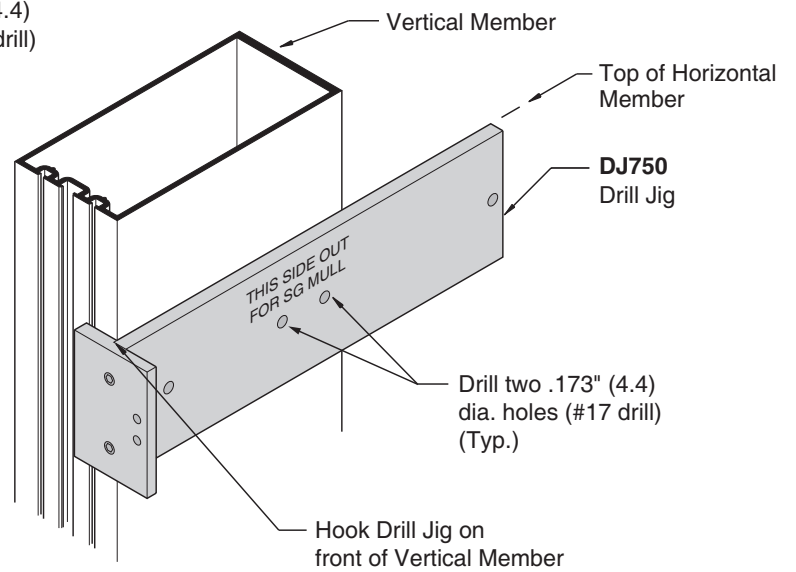

Dim. "A"	Back Member Depth
2 11/32" (59.5)	4" (101.6)
3 11/32" (84.9)	5" (127)
6 11/32" (161.1)	8" (203.2)

Shear Block Assembly

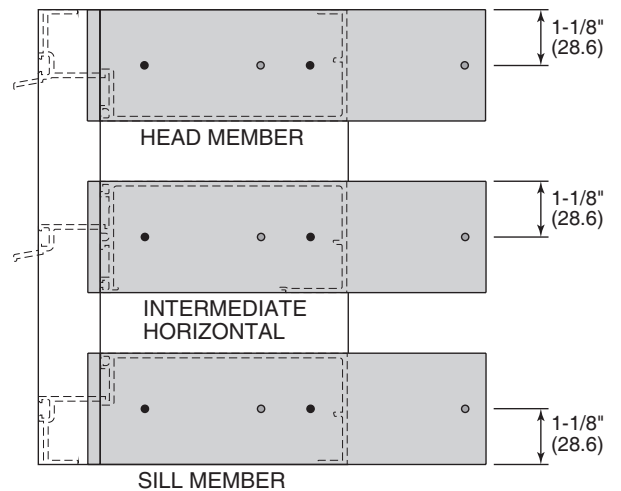

DETAIL B

NOT TO SCALE

SHEAR BLOCK (STICK ERECTED) FABRICATION

3. Fabricate horizontal members to receive horizontal to shear block attachment screws.

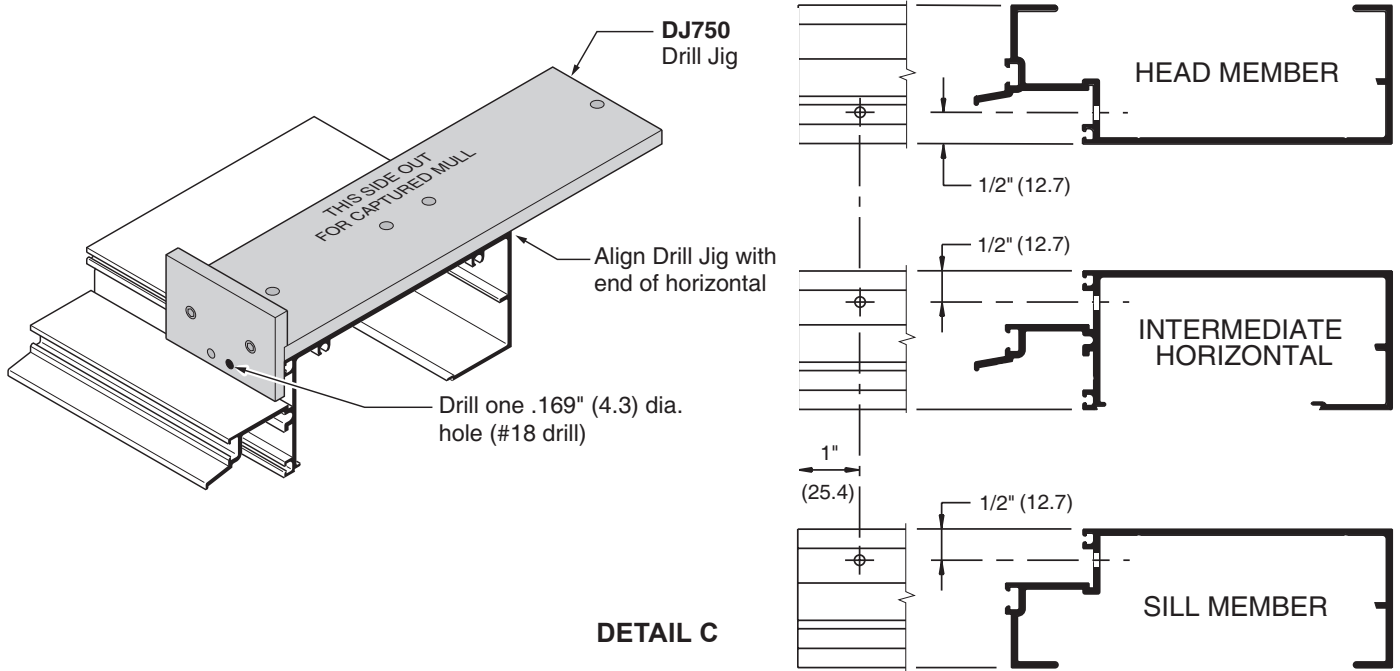

4. Fabricate 8" (203.2) horizontal members to receive horizontal to shear block attachment screws.

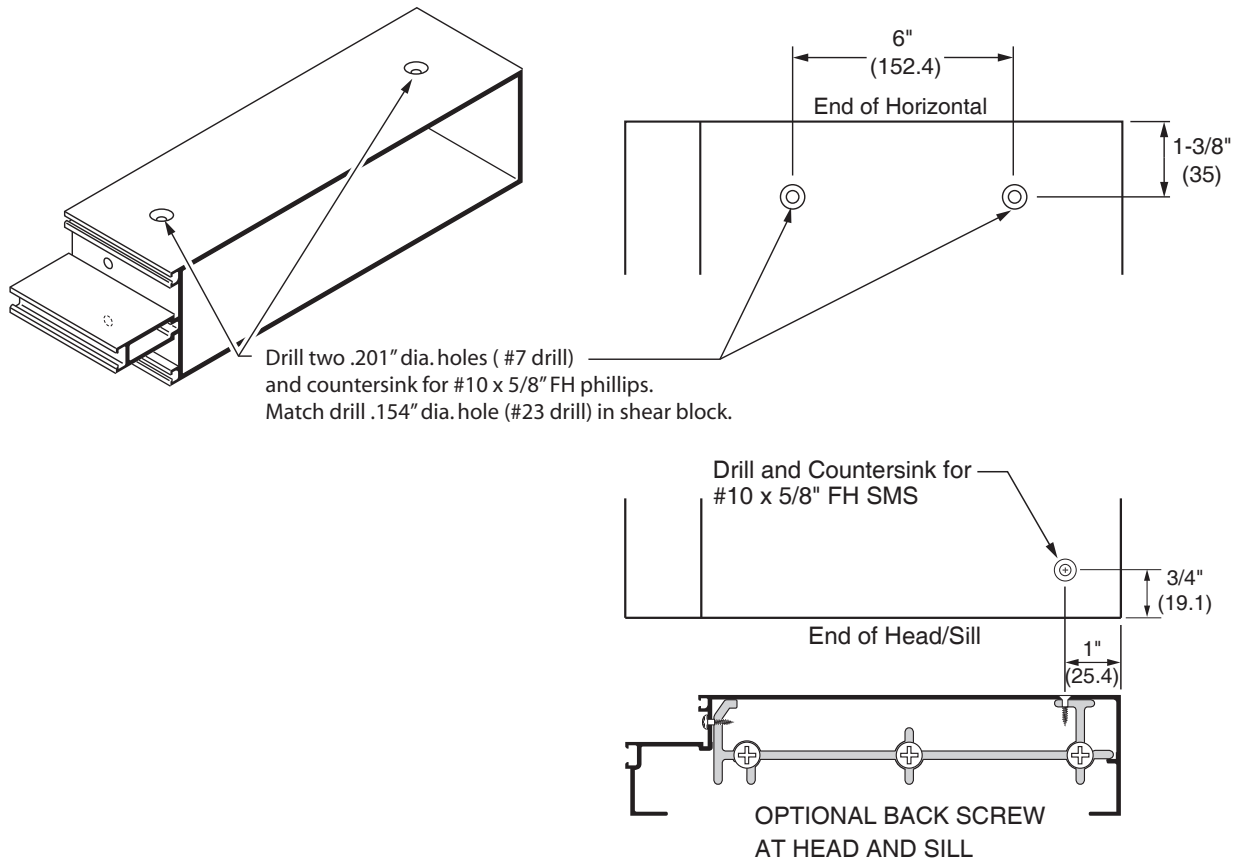

DETAIL D

NOT TO SCALE

SHEAR BLOCK (STICK ERECTED) FABRICATION

- For last bay installation of 8" (203.2) back member intermediate horizontals, a "C" notch is required. Fabricate "C" notch as shown

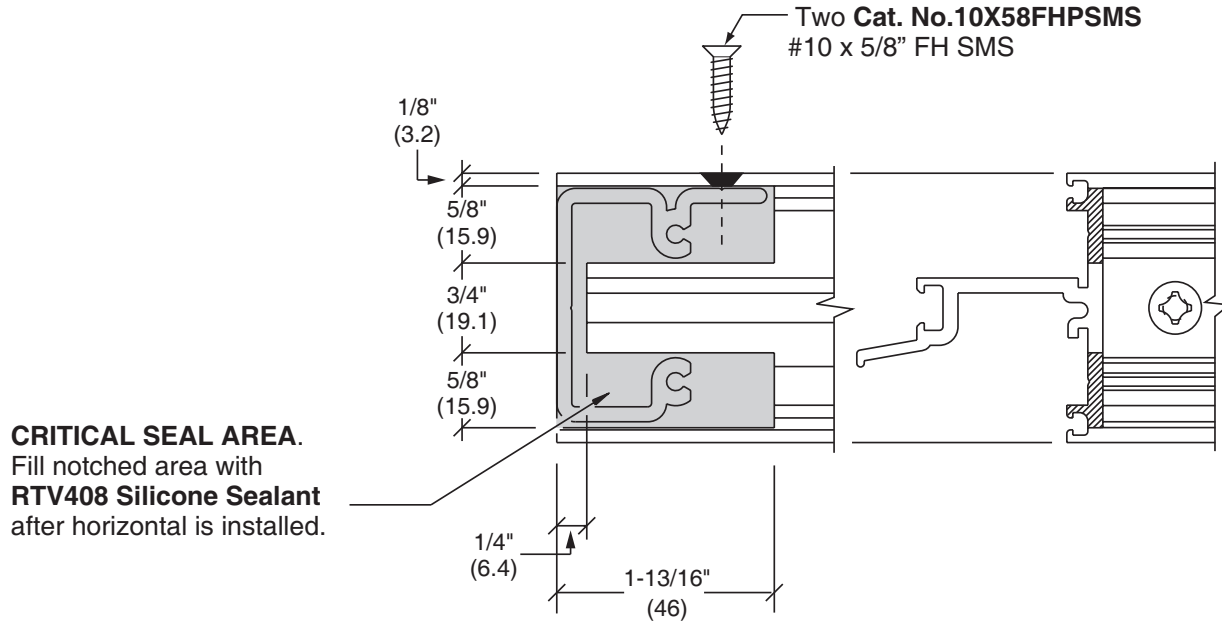

DETAIL E

- Fabricate weep holes in bottom of face covers. Drill 5/16" (7.9) dia. holes at mid-point of daylight opening on bottom side of covers. Butt glazed horizontal covers require one hole centered on each lite of glass.

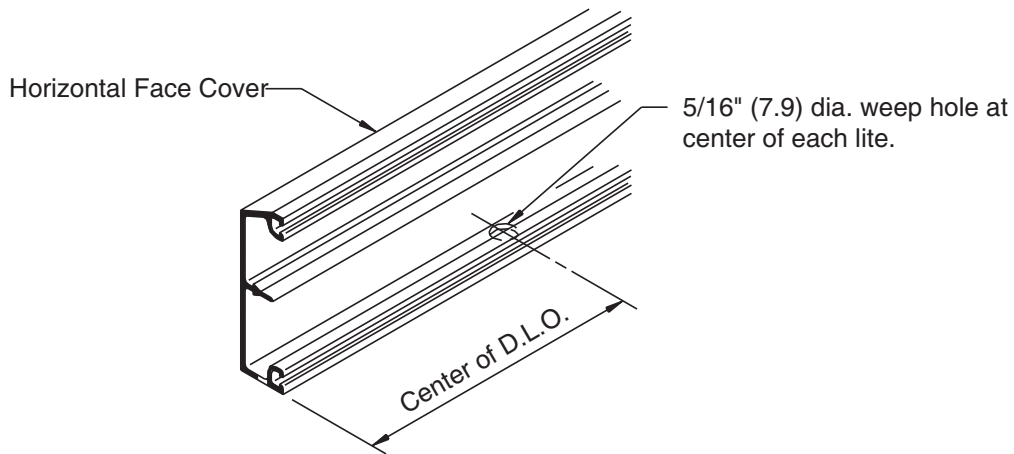

DETAIL F

See page 27 for instructions on how to splice covers.

NOT TO SCALE

SHEAR BLOCK (STICK ERECTED) FABRICATION

7. Drill clear holes in top and bottom of "T" anchors for anchor bolts as per approved shop drawings.

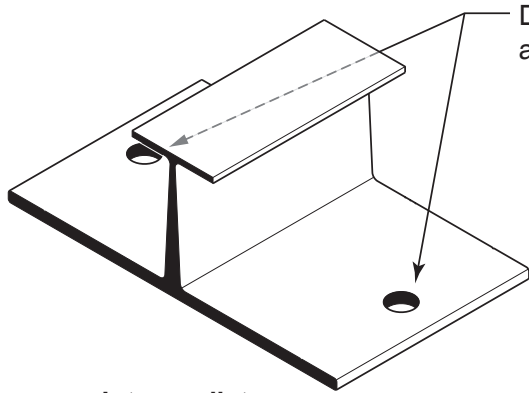

Intermediate Vertical Anchor

Drill per size and type required

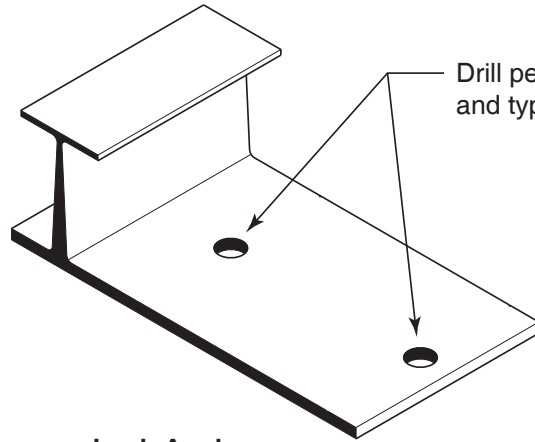

Jamb Anchor

Drill per size and type required

NOTE: "T" anchors must be inserted into mullions before head and sill shear blocks can be installed.

DETAIL G

VERTICAL ANCHORS	JAMB ANCHORS FOR VERTICALS	JAMB ANCHORS
AP514 at TW441 and TW400	AP711 at TW550	AP516 at TW441 and TW400
AP513 at TW410	AP807 at TW815	AP511 at TW410
AP526 at TW424	AP811 at TW810	AP534 at TW424
AP624 at TW524	AP607 at TW841	AP634 at TW524
AP707 at TW530 and TW541		AP704 at TW530 and TW541
AP712 at TW550		
AP804 at TW815		
AP812 at TW810		
AP604 at TW841		

NOT TO SCALE

SHEAR BLOCK (STICK ERECTED) ASSEMBLY

1. Install closure plates on jamb members.

NOTE: Make sure all surfaces are properly prepared according to the sealant manufacturer's recommendations prior to sealing.

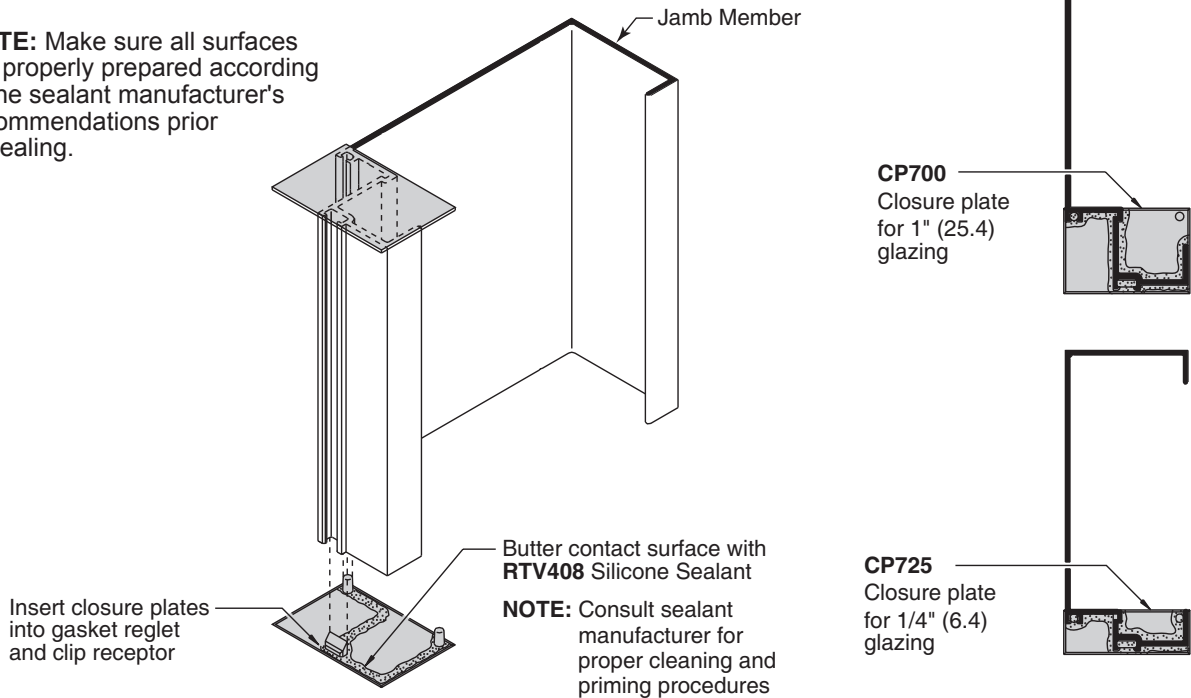

DETAIL H

2. Slide top and bottom "T" anchors into vertical mullions and secure temporarily. Head and sill shear blocks can not be installed until the anchors are in place.

NOTE: Shear blocks can be installed after mullions are set and anchored.

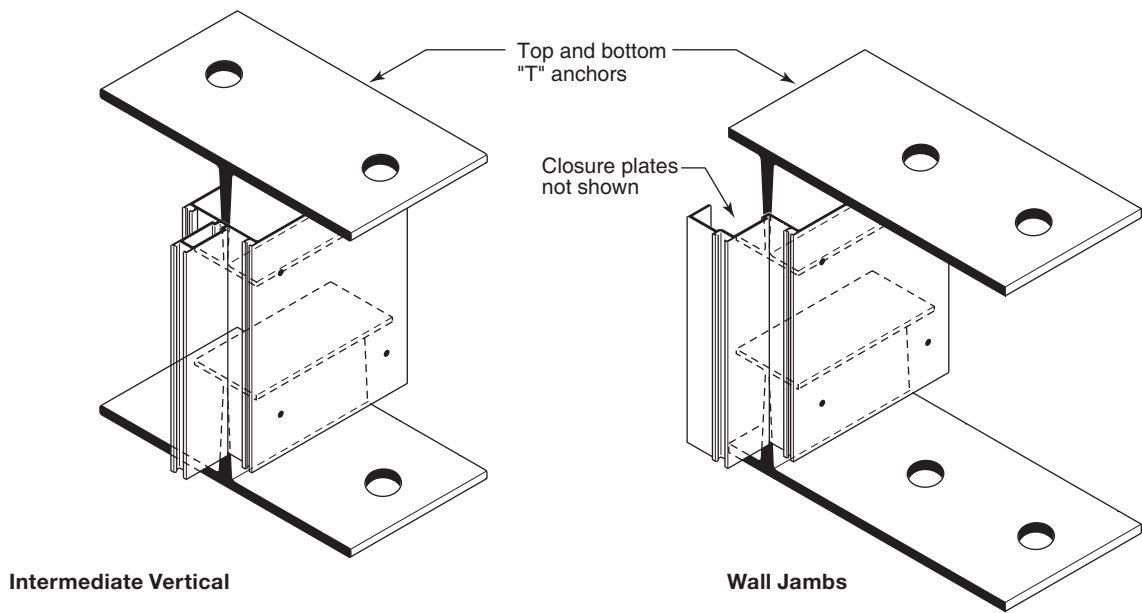

DETAIL I

NOT TO SCALE

SHEAR BLOCK (STICK ERECTED) ASSEMBLY

3. Install shear blocks as shown.

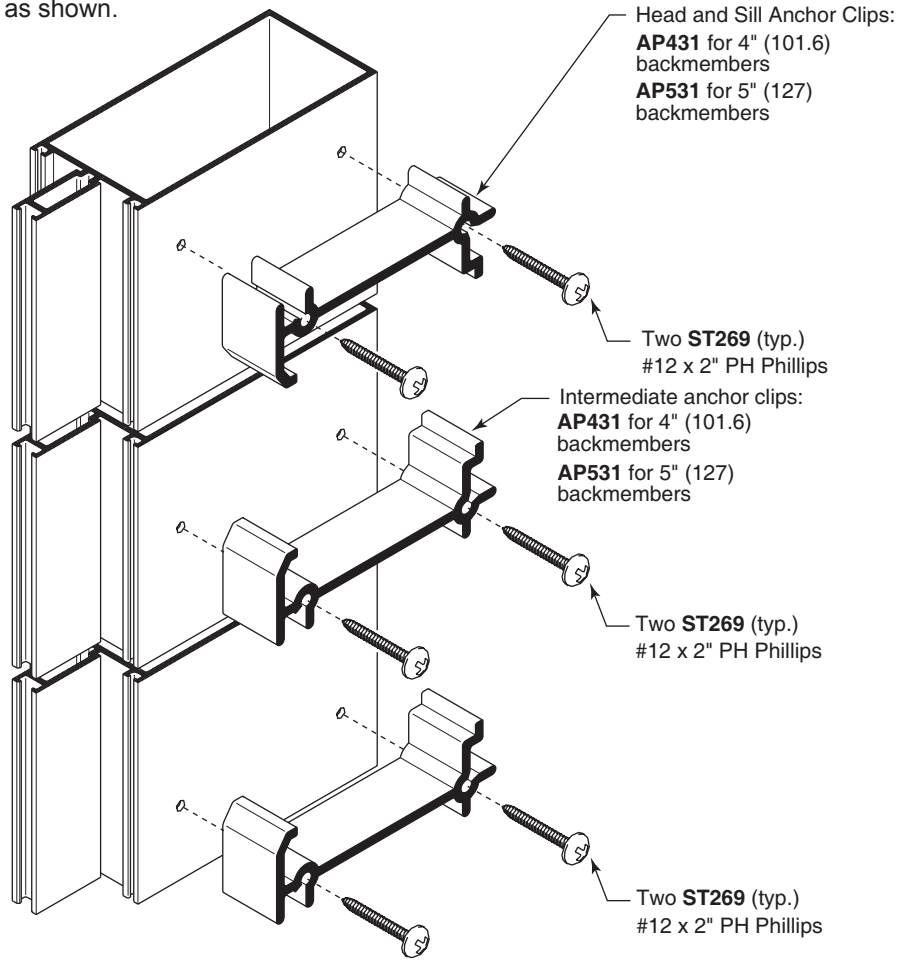

NOTE:
Head and sill shear blocks must be installed after top and bottom "T" anchors are in place.

Typical Shear Block Configuration

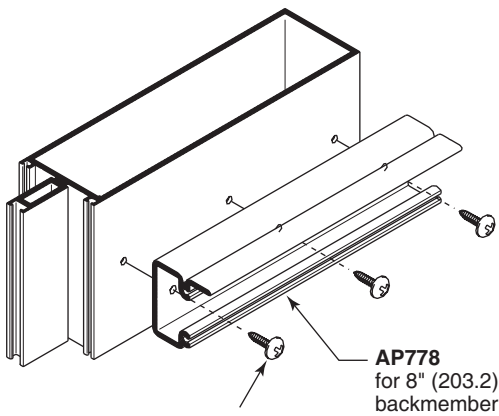

Three Cat. No. 12X34PHPSMS
#12 x 3/4" PH Phillips
(included in set)
SHEAR BLOCK AT 8" (203.2)
INTERMEDIATE HORIZONTAL

AP830 for 8" (203.2)
backmembers

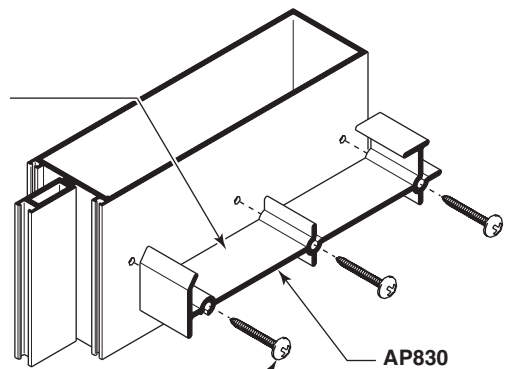

Three ST269
#12 x 2" PH Phillips
(included in set)

SHEAR BLOCK AT 8" (203.2)
HEAD AND SILL

DETAIL J

NOT TO SCALE

SHEAR BLOCK (STICK ERECTION) INSTALLATION

1. Start with jamb mullion, install plumb, level and true. Shim under mullion as needed. Intermediate mullions must be shimmed under both sides of mullion.

When using 8" (203.2) back members, Intermediate Horizontals must be installed at the same time as Vertical Mullions.

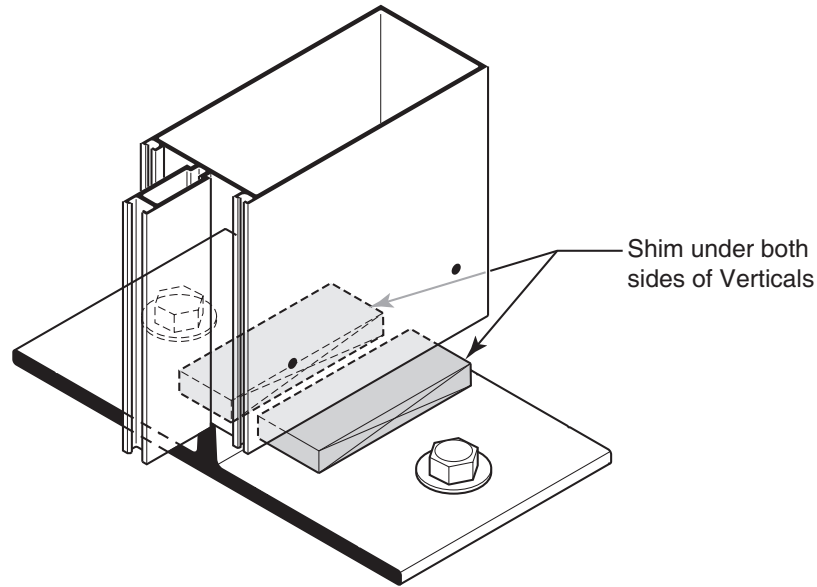

DETAIL K

8" (203.2) BACK MEMBER INSTALLATION

The 8" (203.2) horizontals require that bays be installed in a progressive manner. Intermediate horizontals are installed at the same time as vertical mullions. Intermediate horizontals in the last bay require a "C" notch to facilitate installation. See Page 08 for detailed instructions.

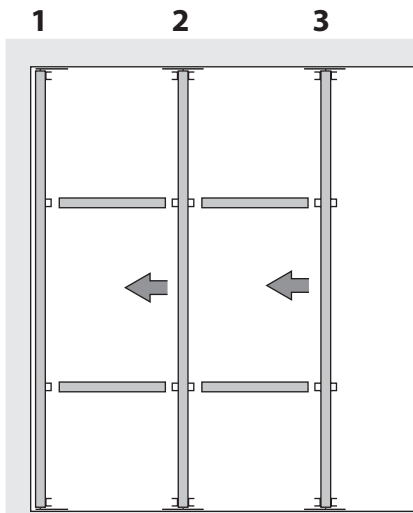

DETAIL L

NOT TO SCALE

SHEAR BLOCK (STICK ERECTION) INSTALLATION

2. Anchor Mullions at floor slab as shown or per approved shop drawings.

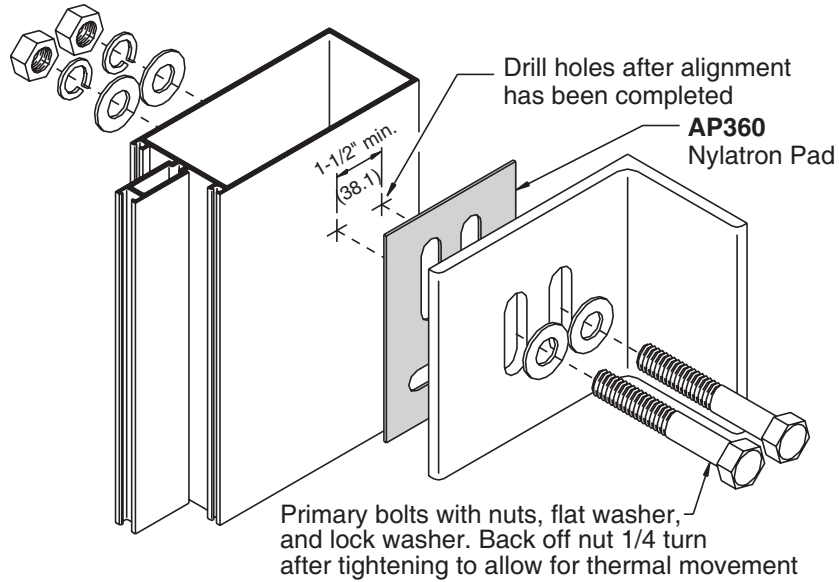

EXPANSION ANCHOR
(Windload Anchor)

DETAIL M

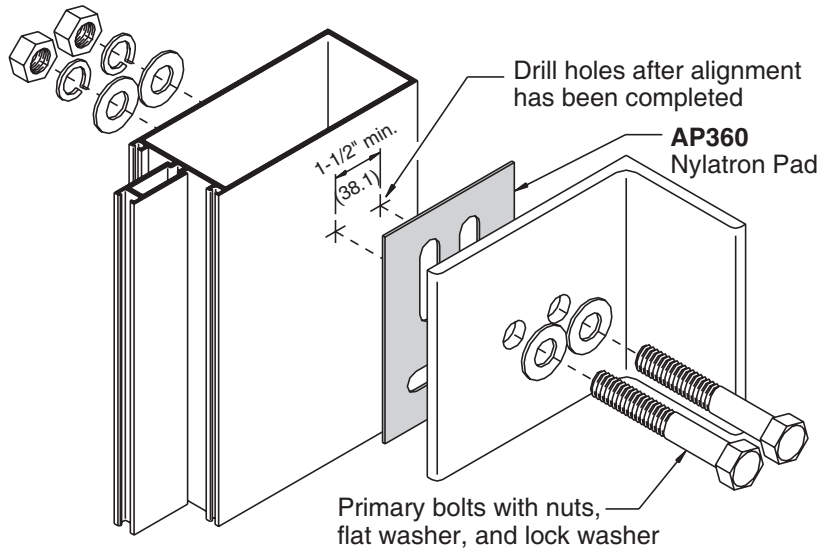

FIXED ANCHOR
(Deadload Anchor)

DETAIL N

NOT TO SCALE

SHEAR BLOCK (STICK ERECTION) INSTALLATION

3. Install splice joints as shown.

Splice joint width should be based on sealant movement capability and on the following formula:

Linear expansion for aluminum, in inches = Length (") x F° difference in temperature x .0000129
 Linear expansion for aluminum, in millimeters = Length (m) x C° difference in temperature x .02322

A 1/2" (12.7) minimum joint is recommended. Use a 1/2" (12.7) spacer shim to set mullion joint constant during erection. Remove the shim after attaching the verticals to the anchors. Splice joints must occur at spandrel areas.

NOTE: Splice joints are designed to accommodate thermal movement only. They do not compensate for variations in floor levels.

A. Clean splice sleeves and all joint surfaces. Apply bond breaker tape at areas where sleeve will be sealed to avoid three sided adhesion.

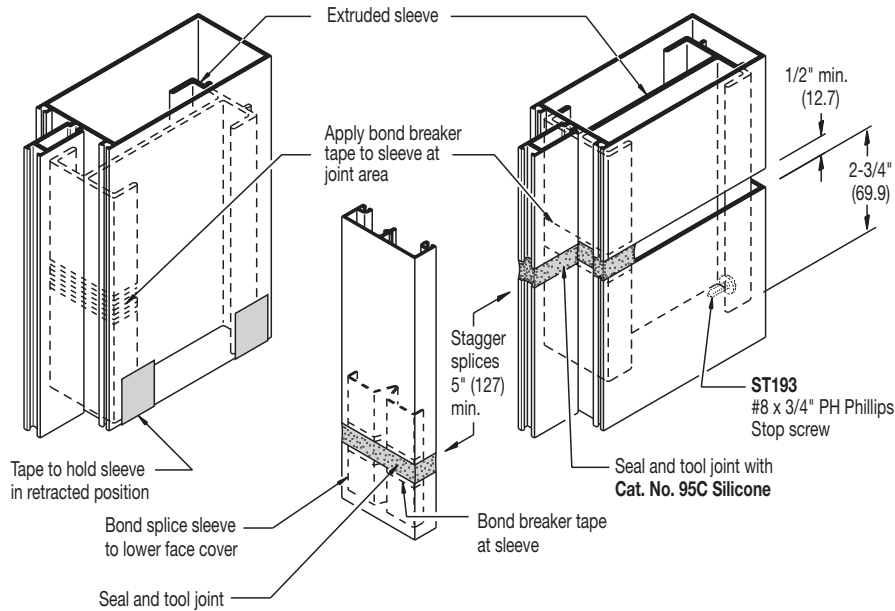

DETAIL O

- B. Slide sleeve into upper member before it is installed and tape to hold it in retracted position.
- C. Install **ST193** #8 x 3/4" PH Phillips stop screw 2-3/4" (69.9) down from top of extrusion at interior of lower member.
- D. Install upper member and let extruded sleeve slide down until it sits on top of stop screw.
- E. Seal joint over sleeve. Do not install vertical transition adaptors in vertical splice joint area until after splice joint is sealed. Vertical transition adaptors must be spliced at the same location as the vertical splice. The face cover splice must be located 5" (127) min. below the vertical mullion splice joint.
- F. Apply bond breaker tape to the face cover splice sleeve where it will be sealed to avoid three sided adhesion. Install face cover splice sleeve in lower cover and bond in place with sealant. After upper face cover has been installed, seal and tool joint between the face covers.

NOT TO SCALE

SHEAR BLOCK (STICK ERECTION) INSTALLATION

4. Install horizontal members. Apply **RTV408 Silicone Sealant** to front face of shear blocks just prior to installing. Secure horizontal members to shear blocks as shown.
5. Install snap-in fillers.

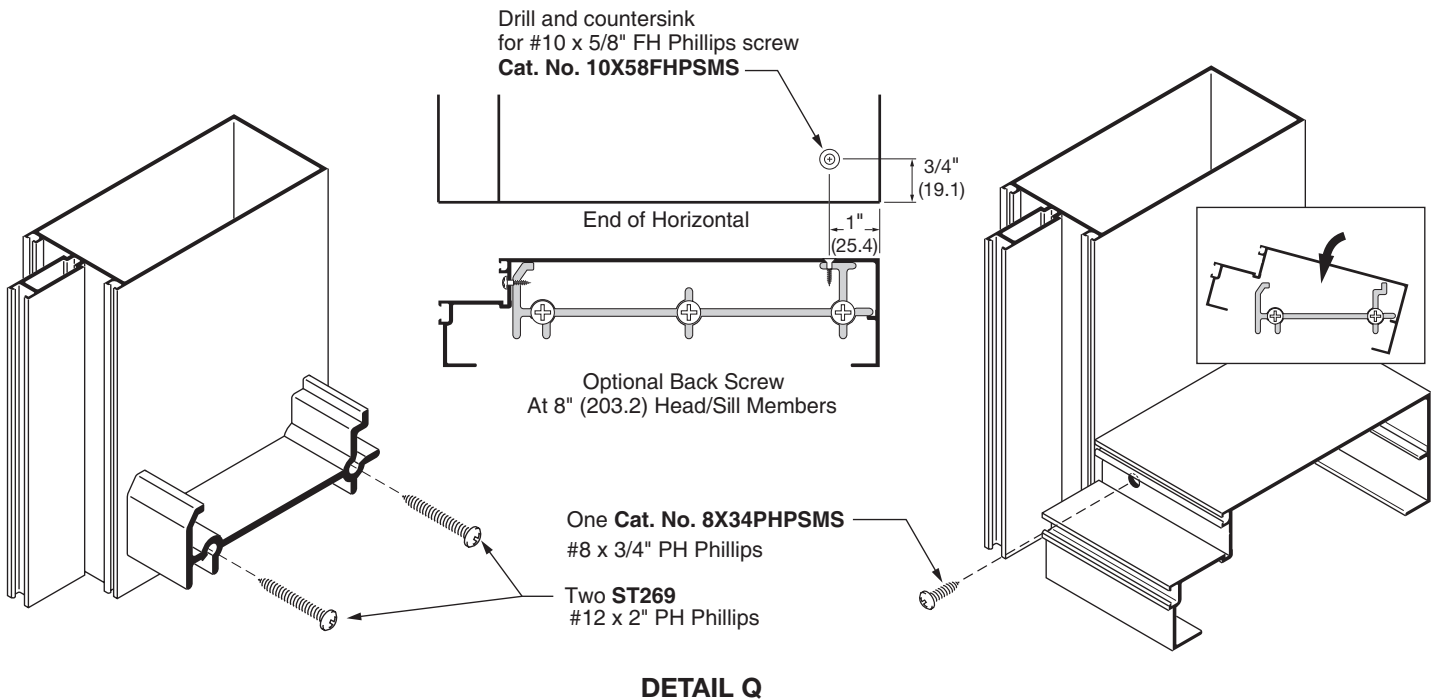
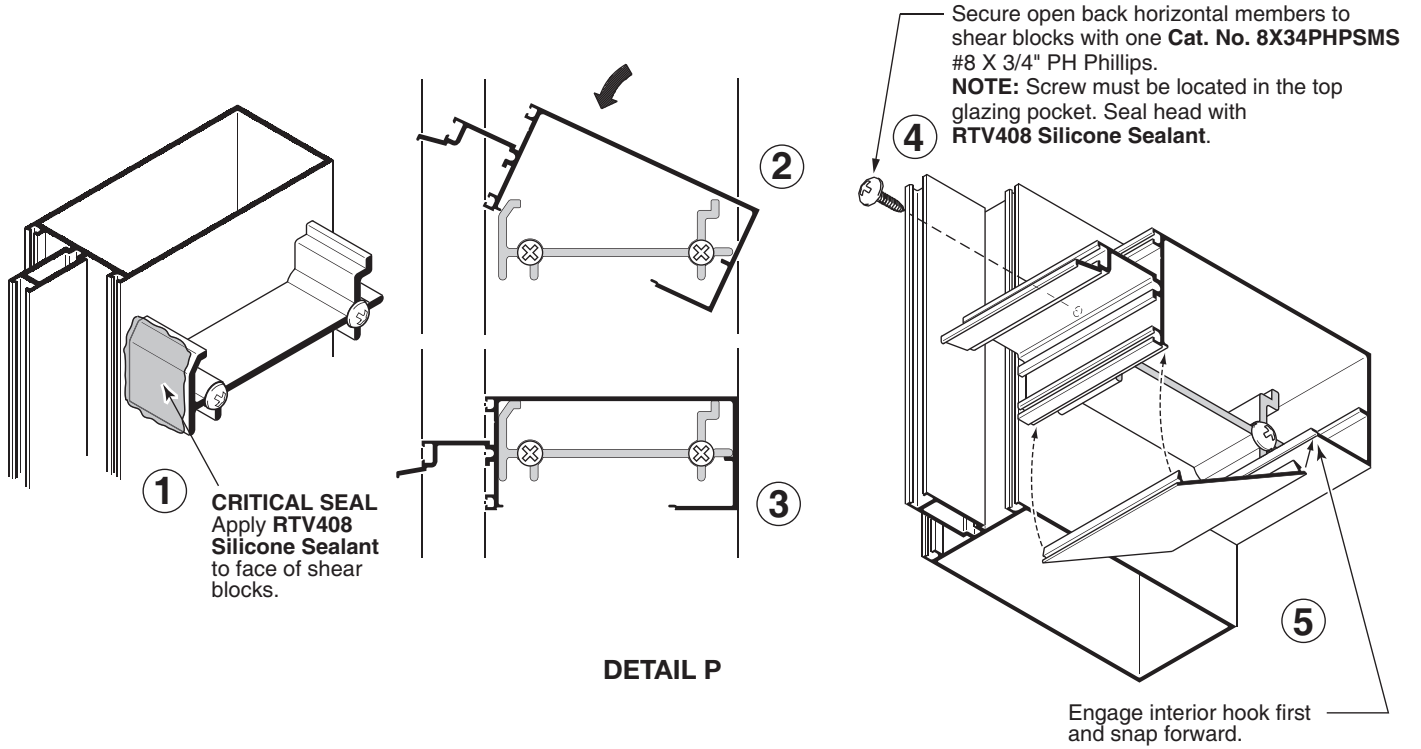

NOT TO SCALE

FABRICATION FOR SCREW SPLINE (PANEL ERECTED) SYSTEM

The Series 4500 Curtain Wall Systems are designed for shear block (Stick erection) and screw spline (Panel erection) type assembly methods. The shear block method of assembly is recommended for multi-floor applications where mullions will be spliced. Illustrations used in these instructions depict the 5" (127) back members for 1" (25) glazing. All other back member depths are treated in a similar fashion unless otherwise noted.

1. Cut members to length.

- Vertical Mullions, Face Covers and Adapters Frame Height
- Horizontal Members and Face Covers Daylight Opening
- Horizontal Snap-In Fillers Daylight Opening minus 1/32" (0.8)
- Vertical Transition Members Daylight Opening plus 1-3/8" (34.9)
- Horizontal Transition Members Daylight Opening minus 1/16" (1.6)
- Butt Glazed Horizontal Face Covers Continuous
- Butt Glazed Vertical Covers Frame Height
- Glass Retainer 3" (76.2) piece of face cover
- Door Jamb Mullions Length (+) plus bottom clearance

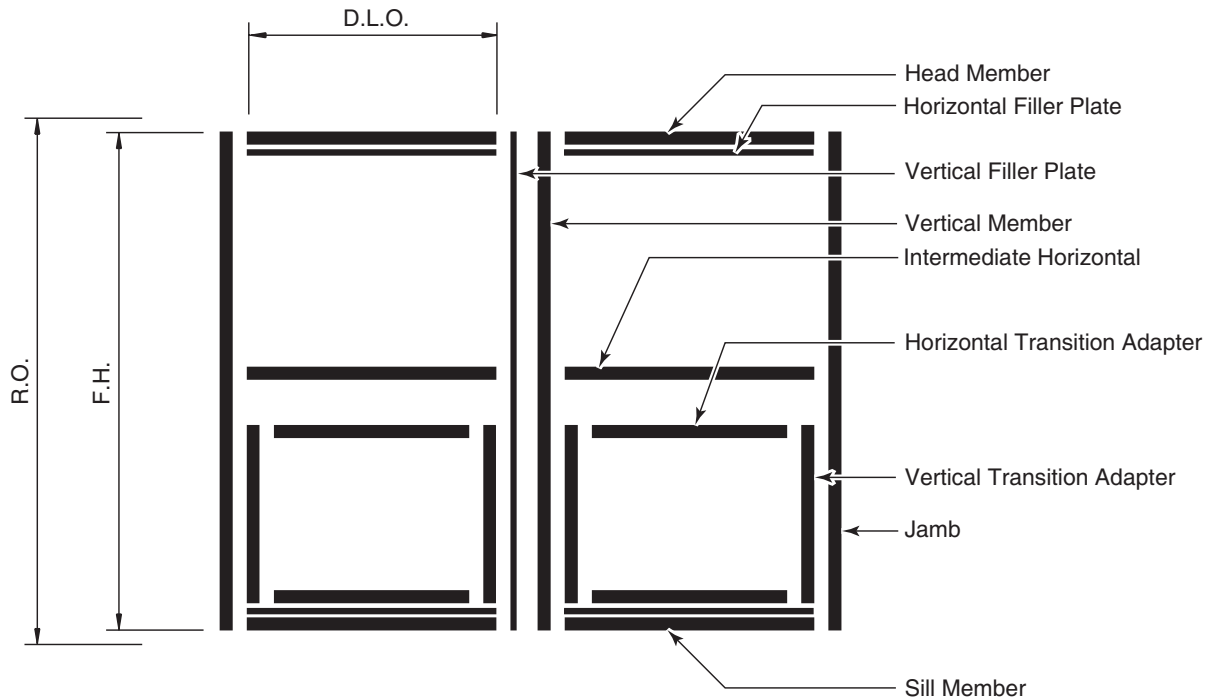

DETAIL R

NOT TO SCALE

FABRICATION FOR SCREW SPLINE (PANEL ERECTED) SYSTEM

2. Fabricate vertical mullions for horizontal attachment as shown. Use Cat. No. **DJ751** Drill Jig.

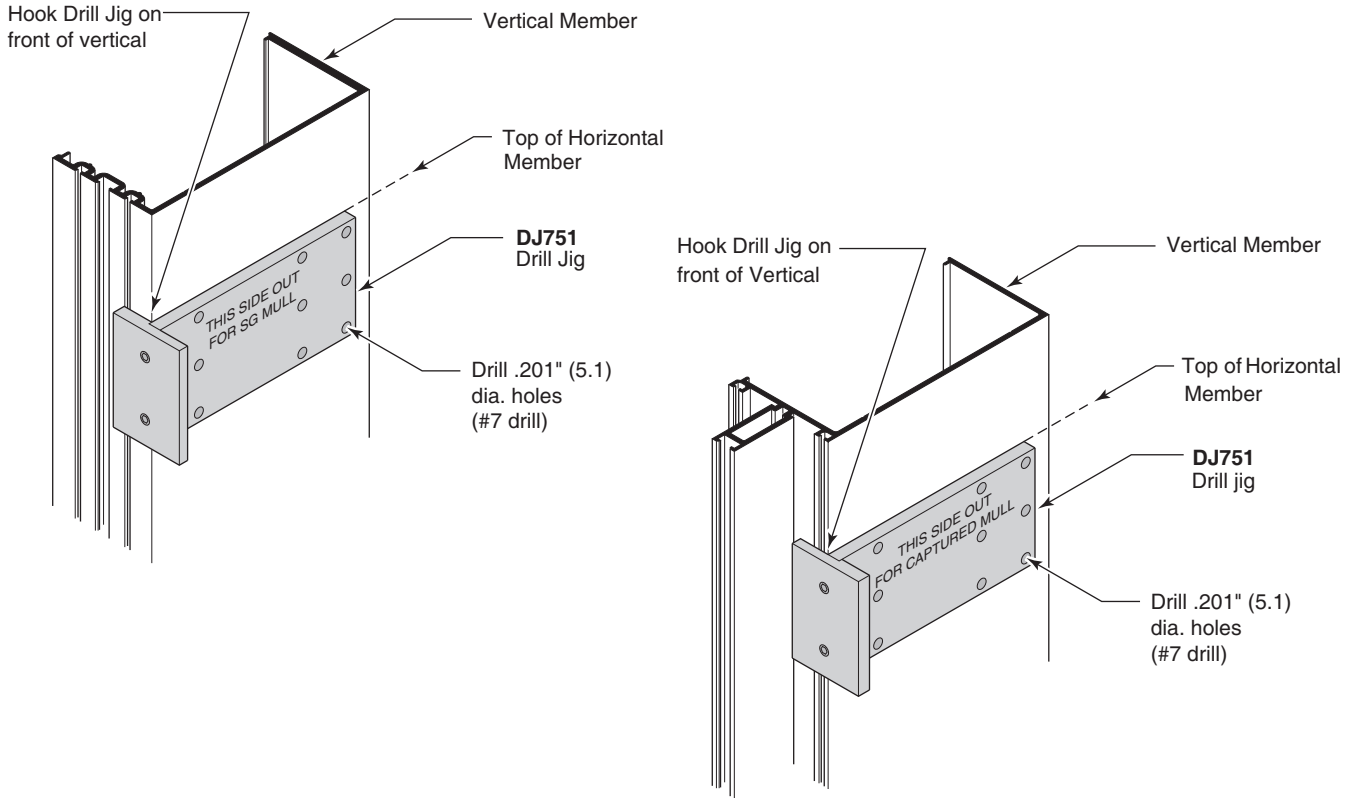

DETAIL S

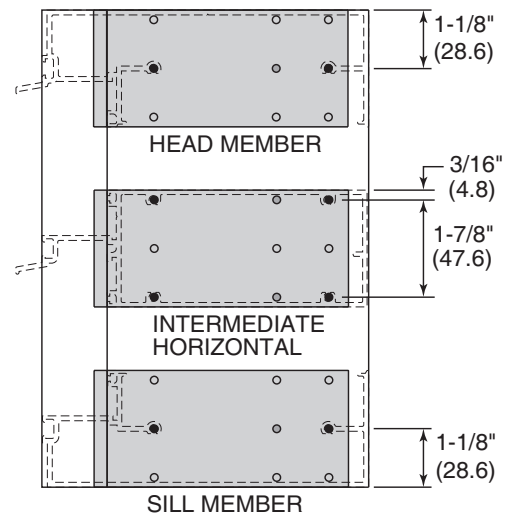
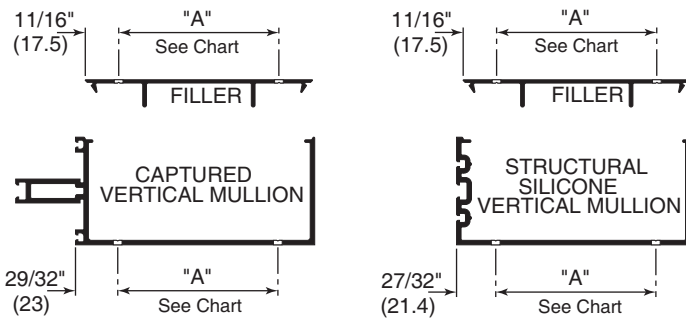

Dim. "A"	Back Member Depth
2-11/32" (59.5)	4" (101.6)
3-11/32" (84.9)	5" (127)

Screw Spline Assembly

NOT TO SCALE

FABRICATION FOR SCREW SPLINE (PANEL ERECTED) SYSTEM

- Fabricate head and sill members for anchor holes. Drill clear holes as shown or per approved shop drawings.

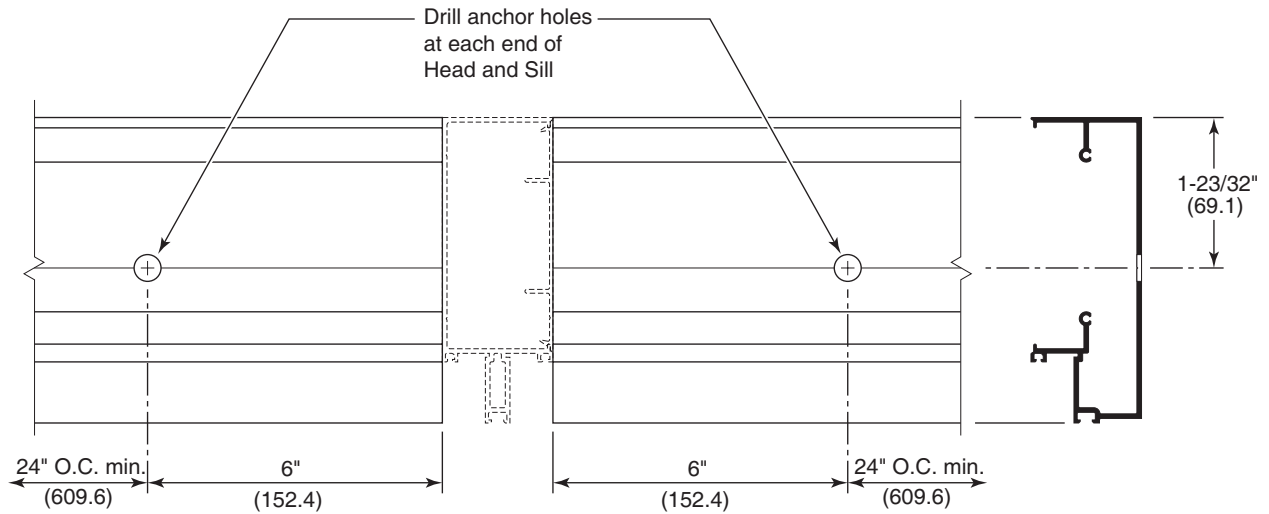

DETAIL T

NOT TO SCALE

ASSEMBLY FOR SCREW SPLINE (PANEL ERECTED) SYSTEM

1. Assemble panels as shown. Apply **RTV408 Silicone Sealant** to the ends of all horizontal members at vertical joints just prior to assembly.

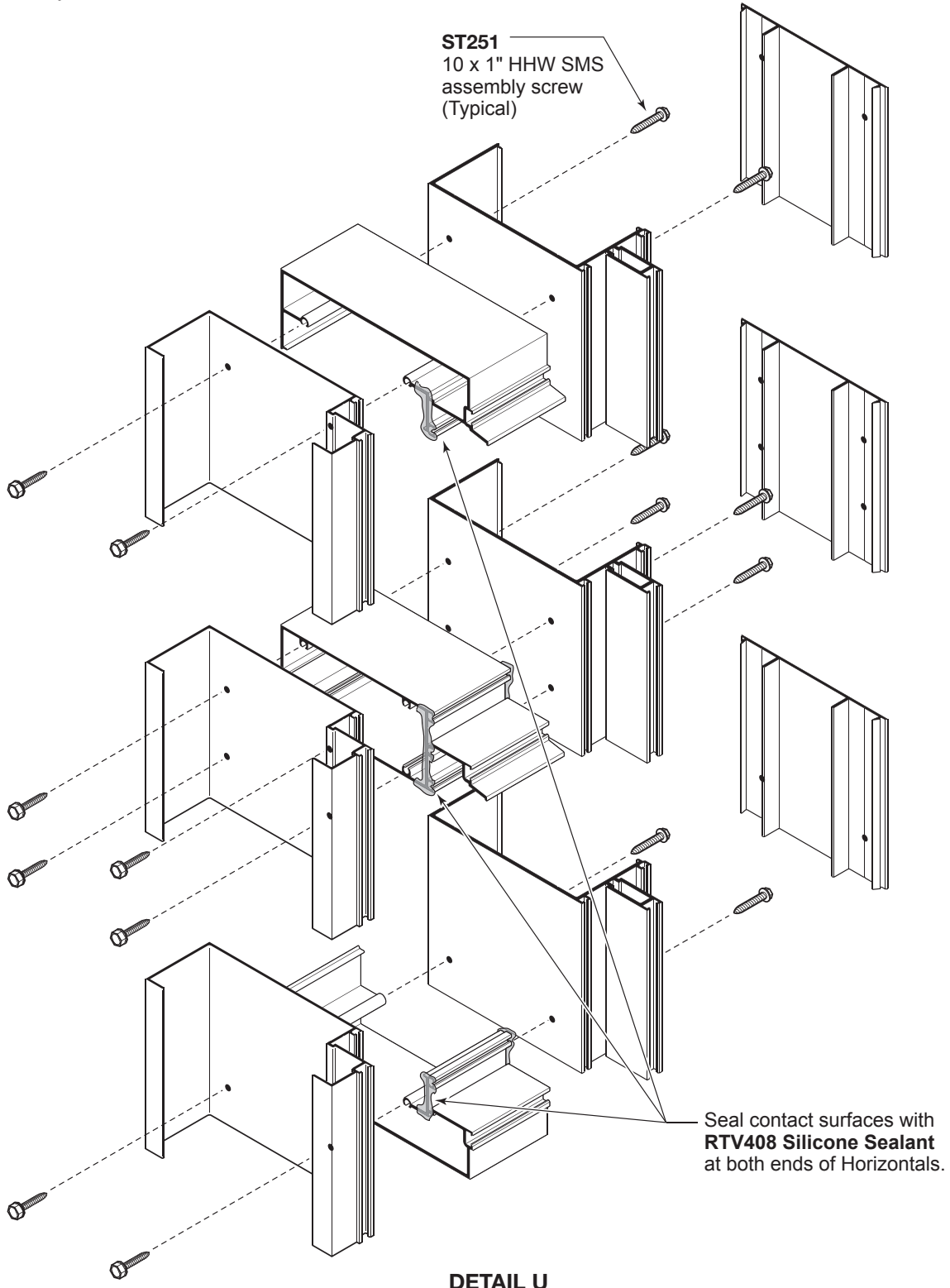

NOT TO SCALE

INSTALLATION FOR SCREW SPLINE (PANEL ERECTED) SYSTEM

- Starting at the wall jamb, set first panel in place, plumb, level and true. Attach head and sill 6" (152.4) from each side of verticals and 24" (609.6) on center, or as shown on approved shop drawings. Always shim at anchor points.

NOTE: Install jamb anchors first if required. Jamb anchors are required if deflection exceeds one half of caulk joint space. See approved shop drawings for jamb anchor locations.

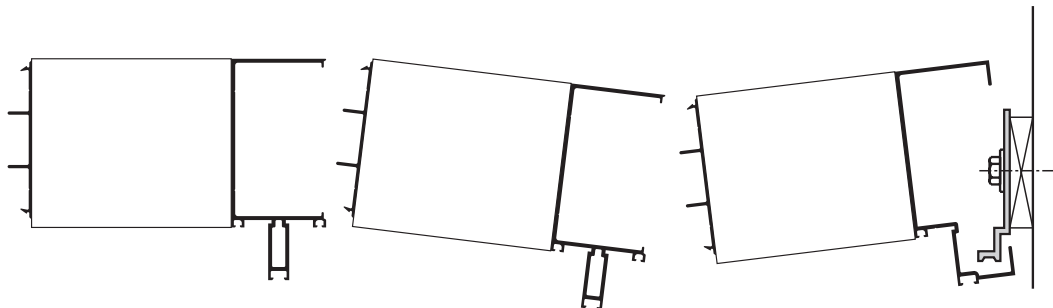
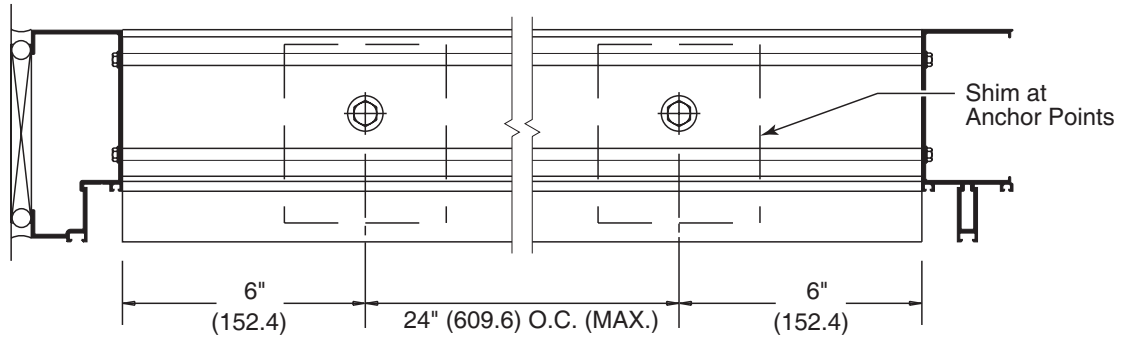

Assembling last bay using optional jamb anchor

DETAIL V

Apply **RTV408 Silicone Sealant** full length prior to frame installation.

Attach with three #12 x 1" FH Phillips **Cat. No. 12X1FHPSMS** (included in package).
Tool excess sealant.

- Install remainder of panels. It may be necessary to install the last two bays as a unit.
- Install head and sill fillers.

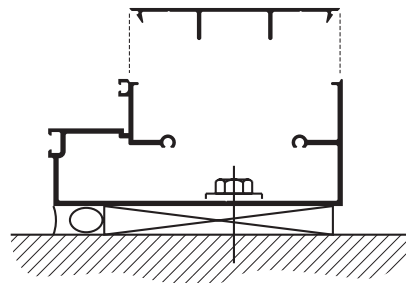

DETAIL W

NOT TO SCALE

INSTALLATION OF WATER DEFLECTORS AND PERIMETER SEALS (ALL SYSTEMS)

1. Apply **RTV408 Silicone Sealant** at three contact surfaces of the plastic water deflectors. Fill the vertical gasket reglet with **RTV408 Silicone Sealant** at the water deflector locations. Seal joints at the face of perimeter water deflectors where it intersects the head and sill members.
2. Snap tabs on the water deflectors into front lip of tongue on vertical and slide down into place. Water deflectors should rest on the horizontal member tongue.

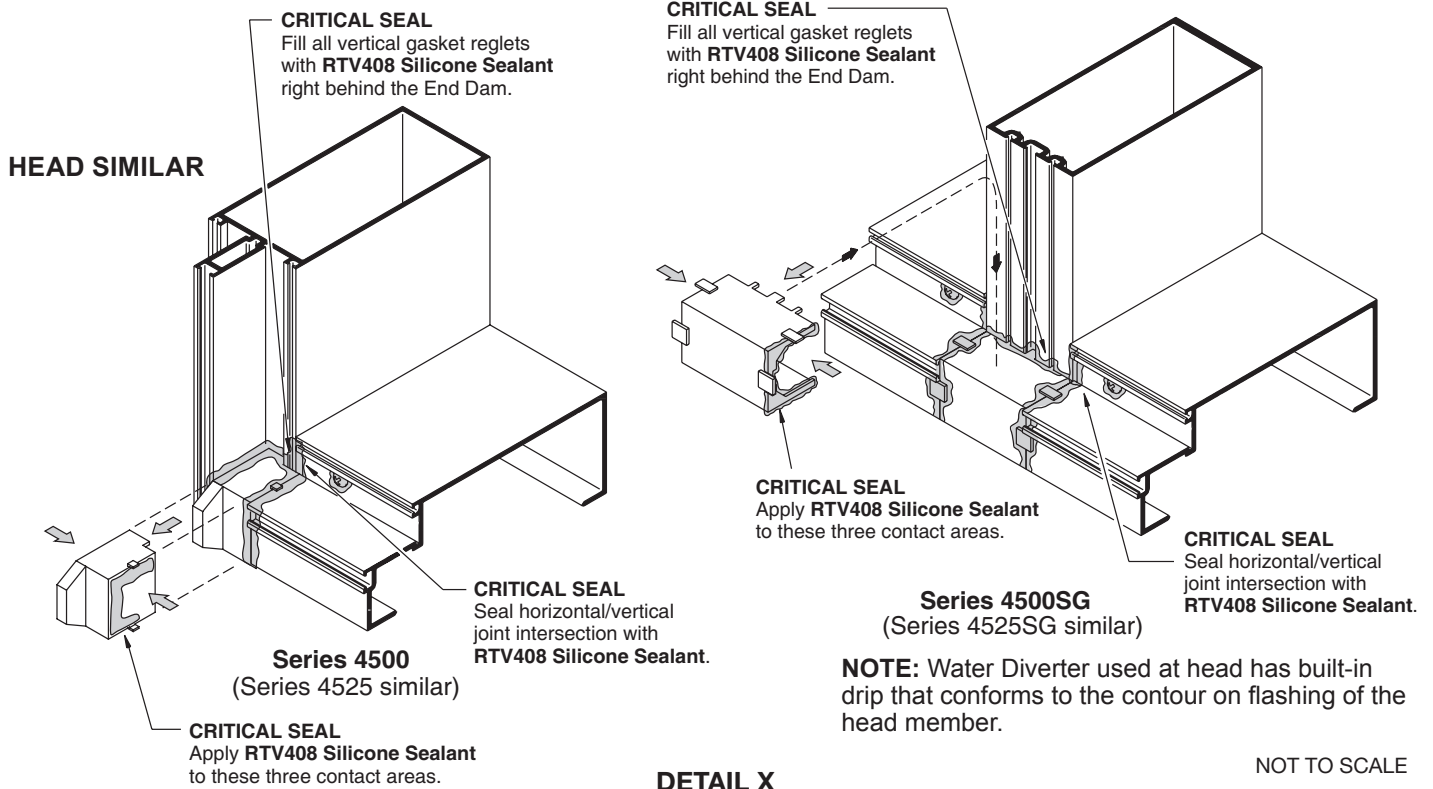
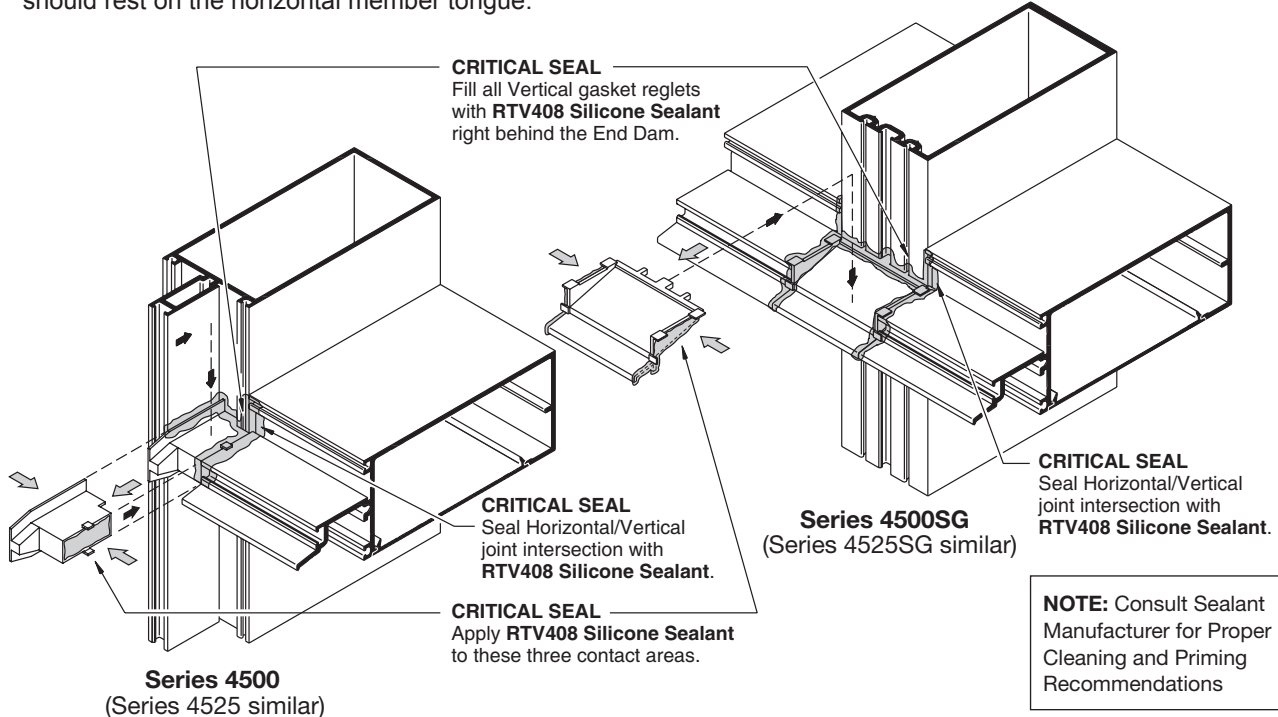

INSTALLATION OF WATER DAMS AND PERIMETER SEALS (ALL SYSTEMS)

3. After all water deflectors are installed, apply continuous perimeter seal with **Cat. No. 95C Silicone Sealant**. Or **M64/M66 Modified Polyurethane Sealant** See **DETAIL Y**.

PERIMETER CAULKING MUST BE INSTALLED PRIOR TO INSTALLING GLASS OR FACE COVERS.

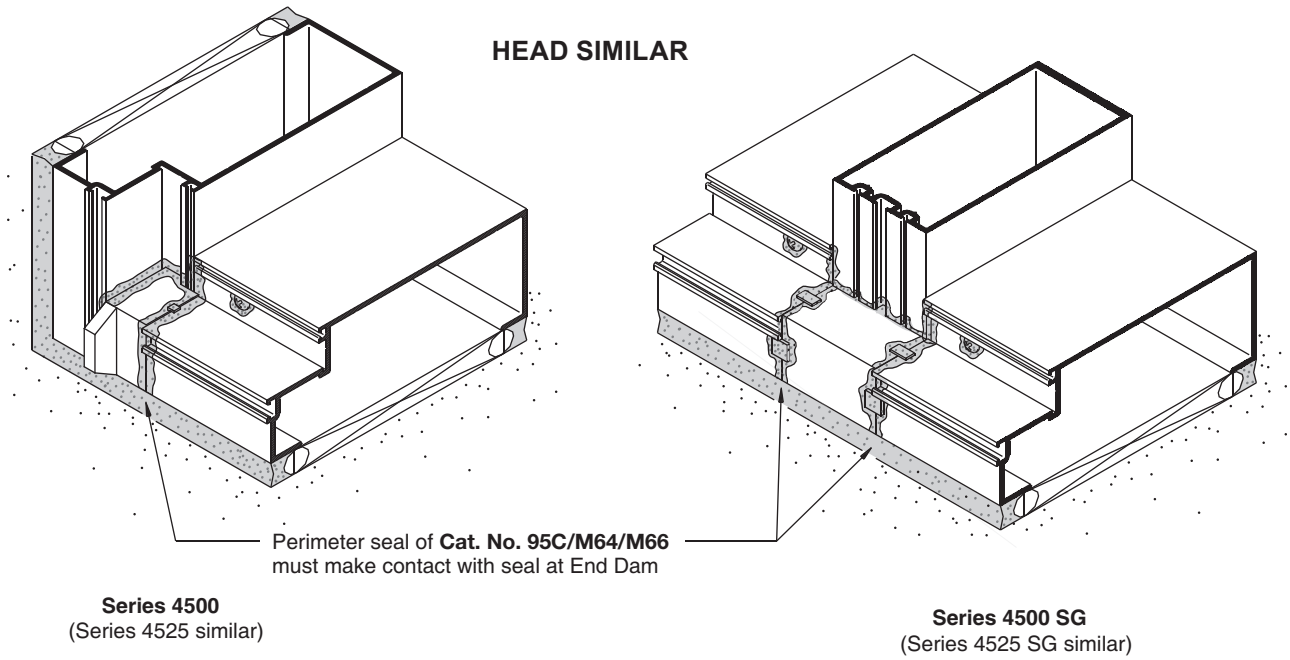

DETAIL Y

NOT TO SCALE

GLASS INSTALLATION (ALL SYSTEMS)

CAPTURED GLASS WIDTH AND HEIGHT = DAYLIGHT OPENING + (PLUS) 1" (25.4)
SILICONE GLAZED GLASS HEIGHT = DAYLIGHT OPENING + (PLUS) 1" (25.4)
GLASS WIDTH = DAYLIGHT OPENING + (PLUS) CALCULATED BITES
GLASS BITES VARY AT CORNER CONDITIONS

These formulas do not take into consideration glass tolerances. Consult glass manufacturer before ordering glass.
 Glass sizes for special conditions must be calculated according to approved drawings.
 In temperatures below 40 degrees Fahrenheit gaskets (4 degrees Celsius) should be warmed and installed before they are allowed to cool again.

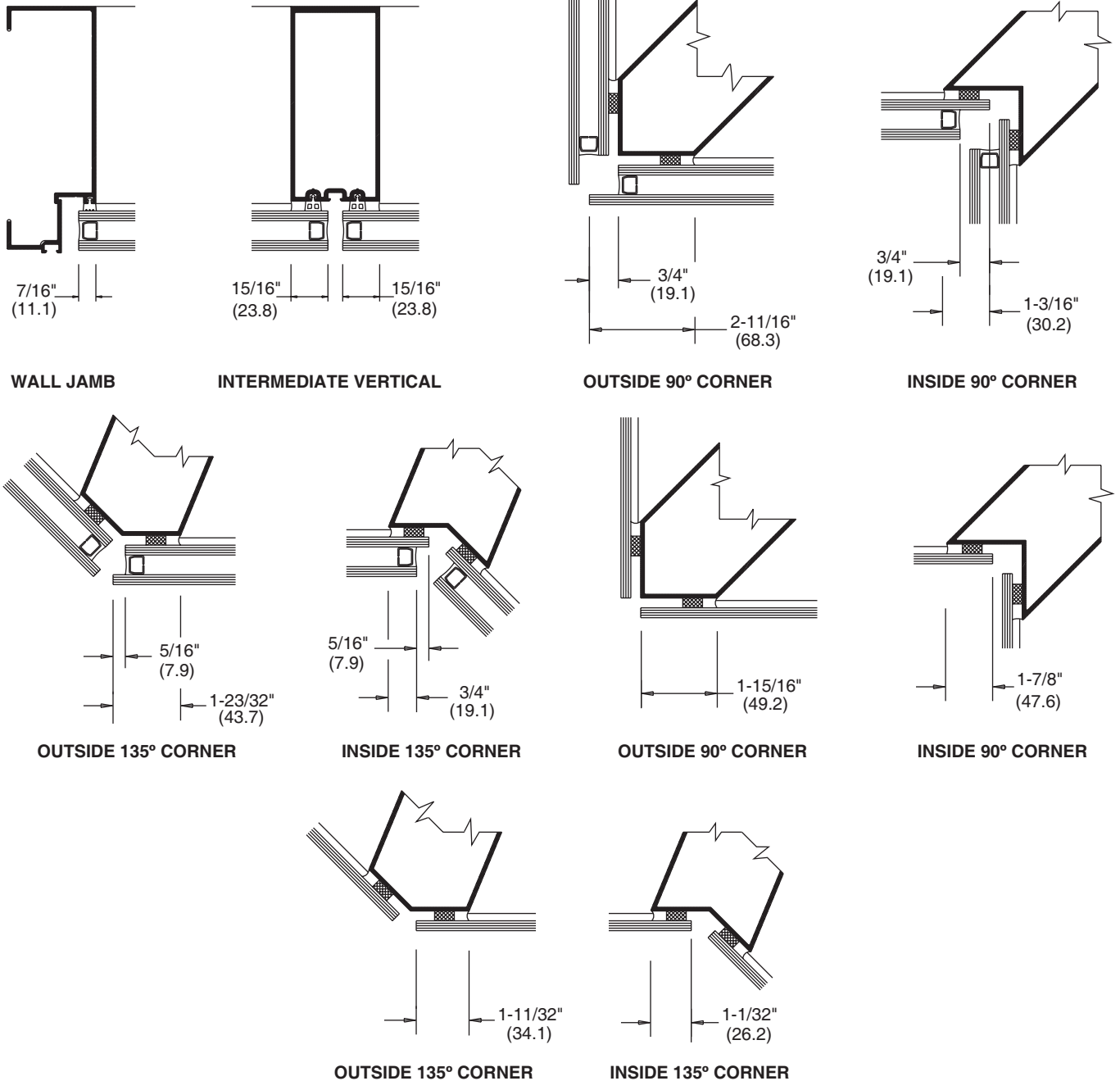

DETAIL Z

NOT TO SCALE

GLASS INSTALLATION (ALL SYSTEMS)

NP716 Sponge Glazing gasket is used on the interior framing members. **NP726** EPDM Glazing gasket is used on the exterior framing members. **SP250** Spacer Gasket is used at structural silicone glazed verticals for the 4500SG and 4525SG Systems.

1. Insert push-in gaskets into all back members and face covers. Vertical gaskets on the mullion run past horizontal gaskets by 1/2" (12.7). Horizontal gaskets butt against vertical gaskets. Face cover gaskets run continuous and should be cut 1" (25.4) long on each end to allow for shrinkage.

NOTE: All glazing gaskets should be cut 1/8" (3.2) longer per foot of aluminum member to allow for shrinkage.

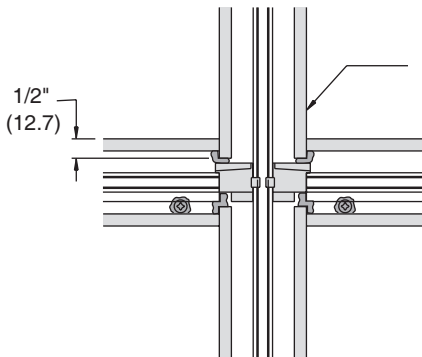

Series 4500

NOTE: Vertical gaskets do not run through to allow for End Dam and Water Diverter installation. They extend approximately 1/2" (12.7) past edge of Horizontal Mullion.

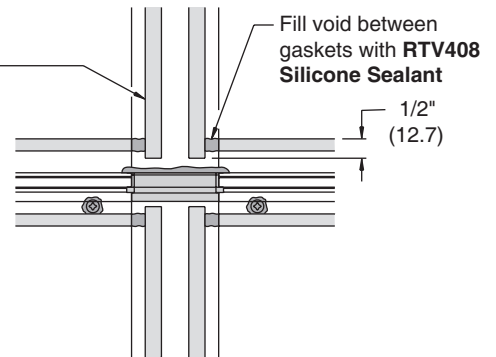

Series 4500SG

Start glazing at bottom and work up.

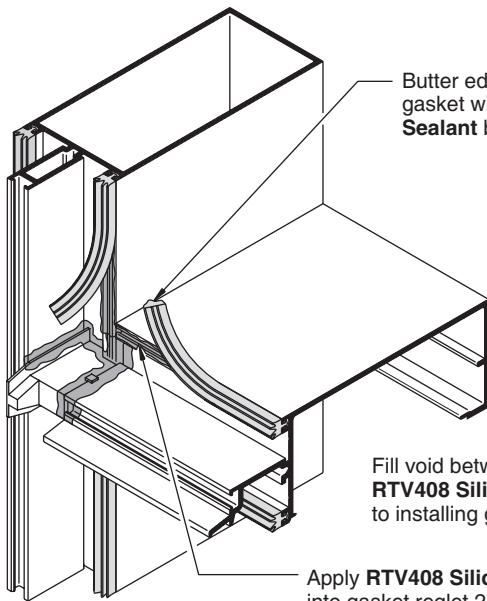

Series 4500
(Series 4525 similar)

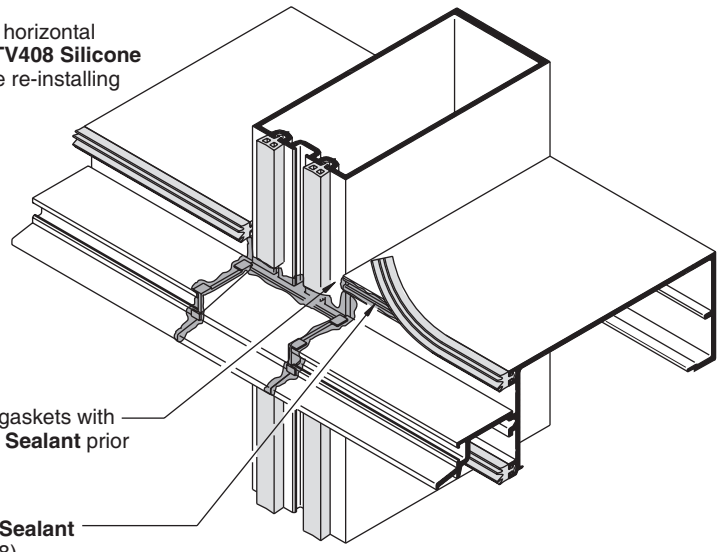

DETAIL AA

Series 4500SG
(Series 4525 SG similar)

NOT TO SCALE

GLASS INSTALLATION (ALL SYSTEMS)

2. Locate two setting blocks at quarter points or as shown on approved shop drawings.

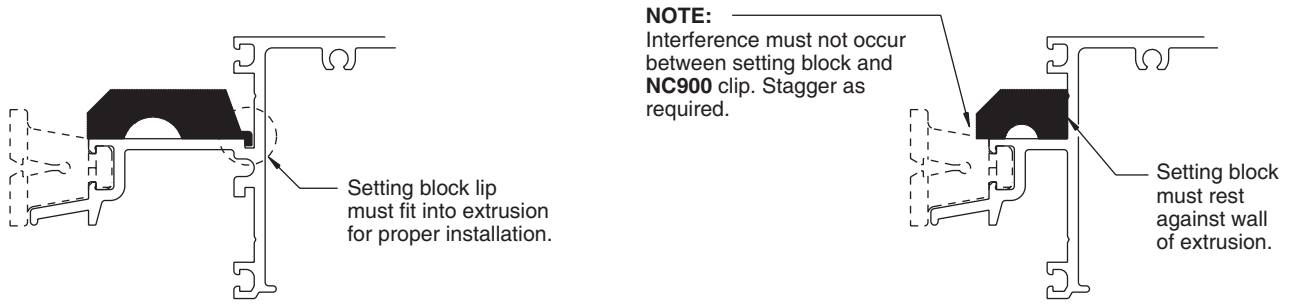

Series 4500 and 4500SG

DETAIL BB

Series 4525 and 4525SG

3. Peel off paper backing from anti-walk blocks and locate one on each vertical at mid-points of the glass height.

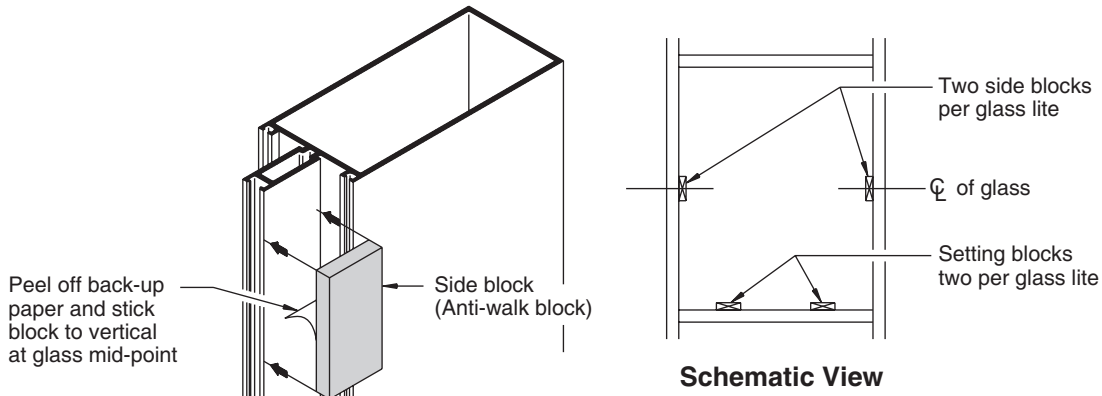

NOTE:
Due to glass tolerances side blocks may be installed after glass is in place.

DETAIL CC

4. Install glass, centering in opening. Hold glass in place temporarily at corners and center of lites with a 3" (76.2) long piece of cover at horizontals and captured verticals. For silicone glazing, hold glass in place with **RG700** glass retainers.

USE THREE RETAINERS IF LITE OF GLASS WEIGHS MORE THAN 350 POUNDS (159 kg).

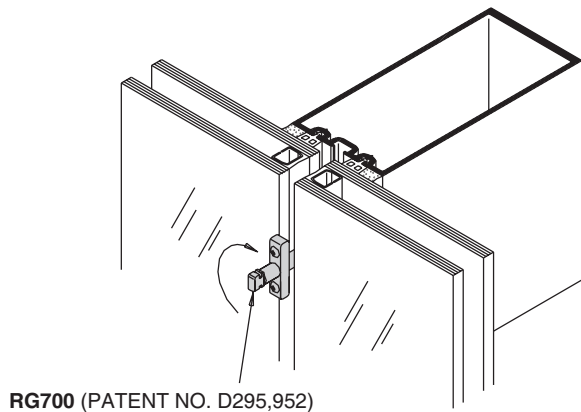

RG700 (PATENT NO. D295,952)
temporary glass retainer for butt
glazed verticals

NOTE: For butt glazed applications, **RG700** should remain in place until the silicone has fully cured. See manufacturer's specifications for curing times. Fill hole after removal of retainer.

DETAIL DD

NOT TO SCALE

GLASS INSTALLATION (ALL SYSTEMS)

5. Install **NC900** Face Cap Clips as described below. To install clips, twist clockwise.

NC900 Face Cap Clip spacing

Horizontal Members:

2" (50.8) from each end

2" (50.8) from center of each lite

6" (152.4) on center

Vertical Members:

2" (50.8) from each end

2" (50.8) from center of horizontal member

6" (152.4) on center

Splice Joints:

2" (50.8) from each side of joint

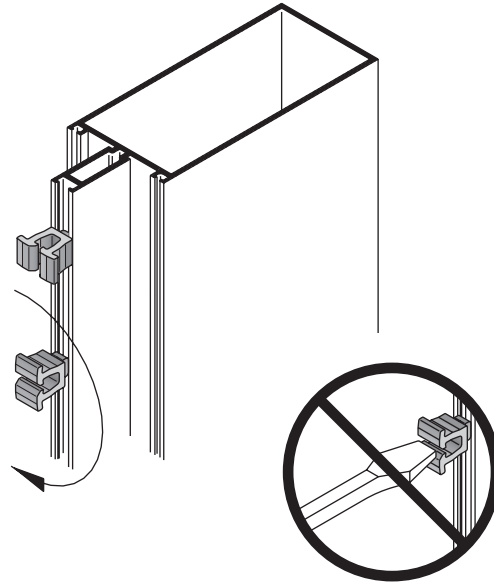

DETAIL EE

6. Mark locations of each **NC900** Face Cap Clip on the glass. This will assist in knowing where clips are when installing covers.

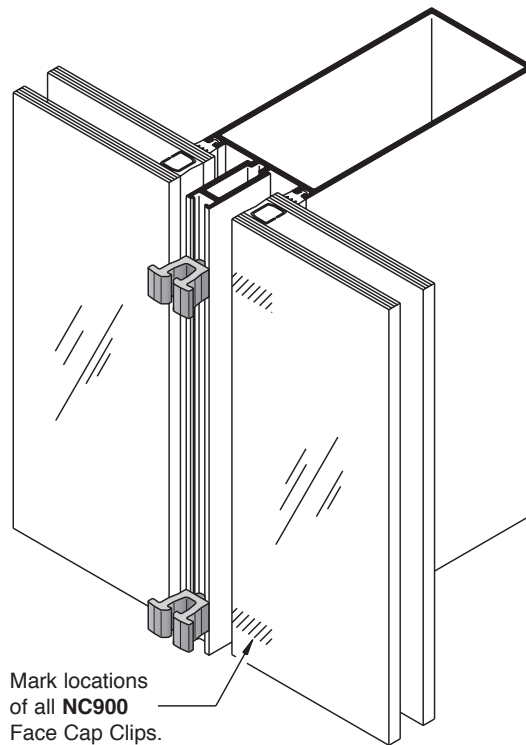

DETAIL FF

NOT TO SCALE

FACE COVER INSTALLATION (ALL SYSTEMS)

1. Remove temporary retainers. Install all vertical face covers first.

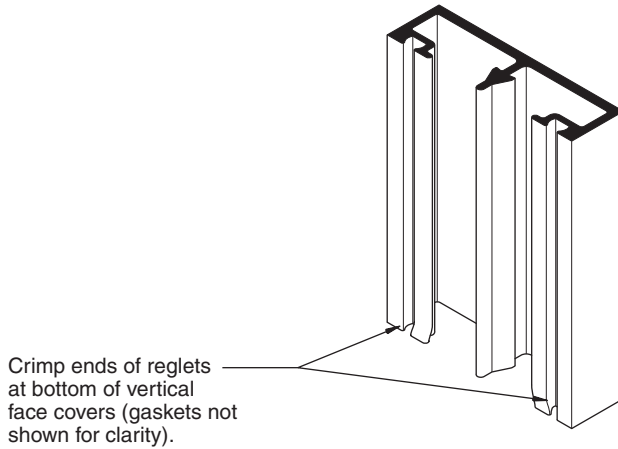

Prior to installing face covers, trim previously installed gaskets to length of cover. On vertical face covers, it may be necessary to crimp each reglet at the bottom of the cover to retain gaskets during installation.

DETAIL GG

Install vertical face covers from top to bottom and horizontal face covers from the center outward. Care must be taken to prevent damage to face covers during installation. Use a 2" (50.8) x 4" (101.6) x 12" (304.8) piece of wood and a **CRL Soft-Face Power Hitter CAT. NO. ST57532** to engage face covers. Use the marks on the glass locating **NC900** Face Cap Clips to engage covers at clips. Only hit covers at clip locations.

2. Pinning of vertical face covers is required to prevent covers from sliding. Use one screw per cut length nearest the center of the length. Locate the screw so that it rests on the top edge of the bottom wall of the horizontal face cover, concealed from view. Install as shown.

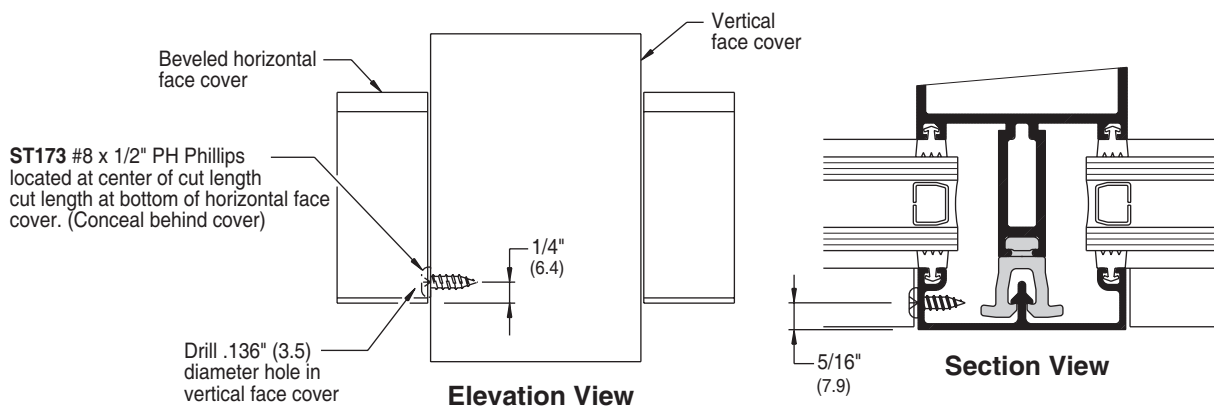

DETAIL HH

NOT TO SCALE

FACE COVER INSTALLATION (ALL SYSTEMS)

3. Install horizontal face covers. Use same procedure as vertical covers, striking the covers only at clip locations. Always install horizontal face covers with beveled edge on top.

When splicing horizontal face covers, always locate splice at centerline of glass butt joints. Splice should be 1/2" (12.7) or based on formula for linear expansion for aluminum specification and sealant movement capability. See page 22 for formula.

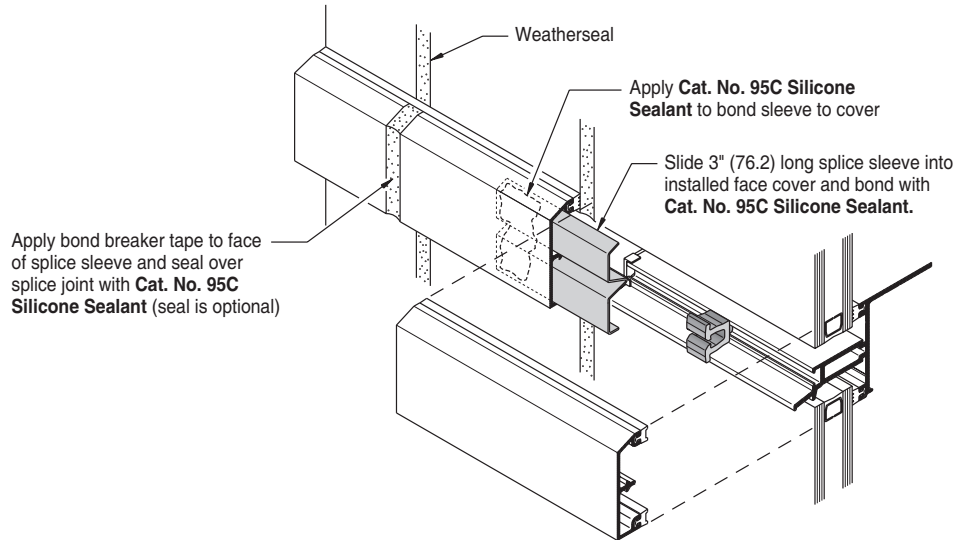

DETAIL II

4. After frame has been glazed and face covers installed, seal corners of all interior gaskets. Tool excess sealant.

NOTE: Exterior gaskets and face covers not shown for clarity

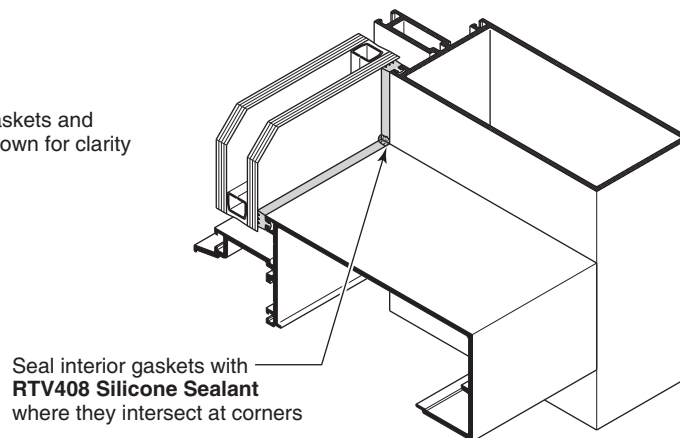

DETAIL JJ

NOT TO SCALE

TRANSITION GLAZING (ALL SYSTEMS)

1. Apply sealant into gasket reglets before installing snap-in transition members.
2. Install vertical adapters first. Center in daylight opening.
3. Install horizontal adapters and seal horizontal to vertical joints with **RTV408 Silicone Sealant**. Tool sealant into joints.
4. Follow normal glazing procedures.

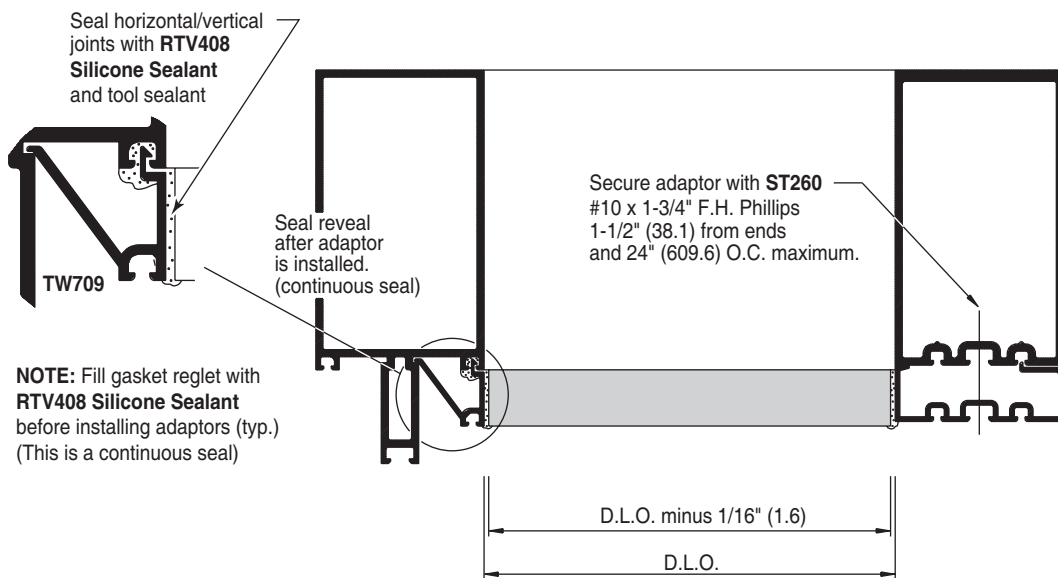
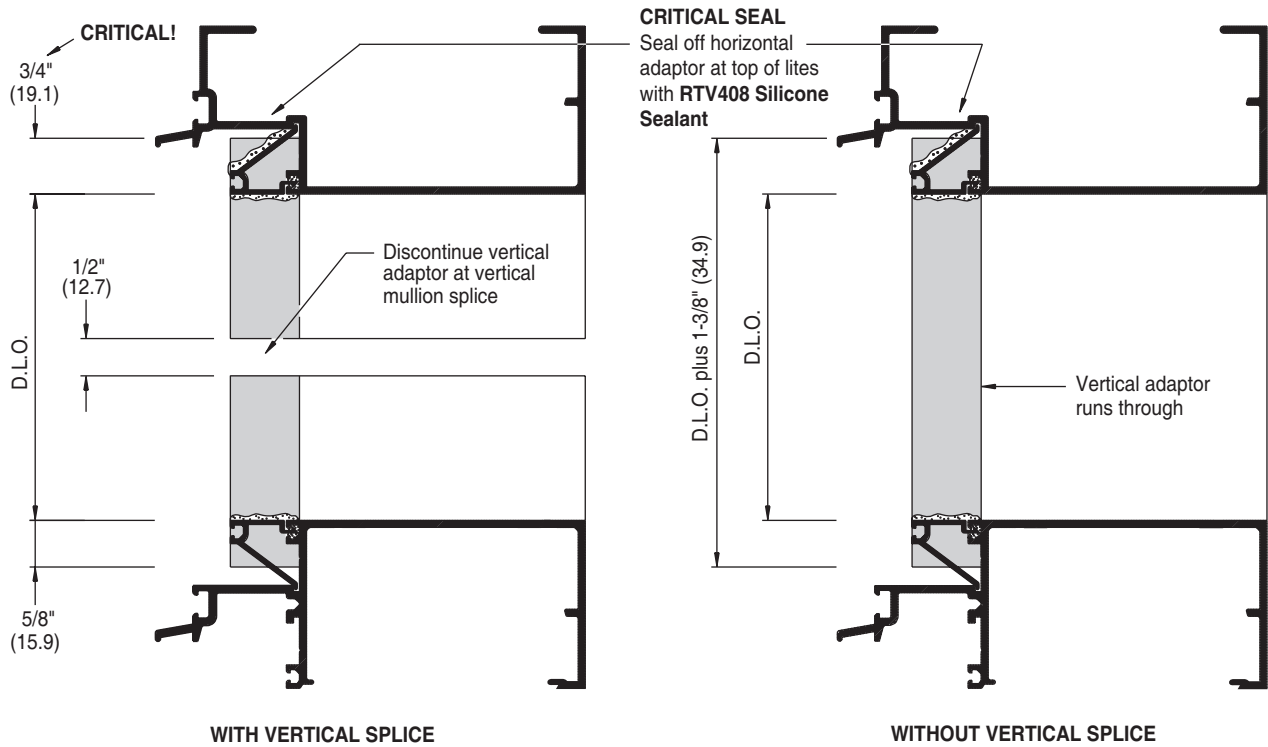

NOT TO SCALE

DOOR FRAME INSTALLATION (ALL SYSTEMS)

1. Cut vertical mullions that will accept door subframe to frame height plus bottom clearance. Mullions that will accept door subframes run to the floor. For multiple span installations, cut to typical mullion length plus clearance.
2. Cut horizontal member above door header subframe to standard cut dimension as shown on page 15.
3. Drill holes at the bottom of the door jamb mullion for anchor screws.
4. **STICK TYPE ERECTION:**
Prior to installing sill horizontal adjacent to door frame, secure and seal vertical mullion door jamb to the floor.
PANEL TYPE ERECTION:
Secure mullion to the floor before the next panel is installed.
5. Prior to installing door frame, apply pocket fillers to curtain wall header and jambs. Seal screw heads at pocket filler for Series 4525 applications.

NOTE: Horizontal member above door frame must be installed with screw heads sealed before pocket fillers can be installed.

6. Assemble and install door frame and door in opening per instructions as shown in the Entrance Doors and Frames section of the Installation Manual.

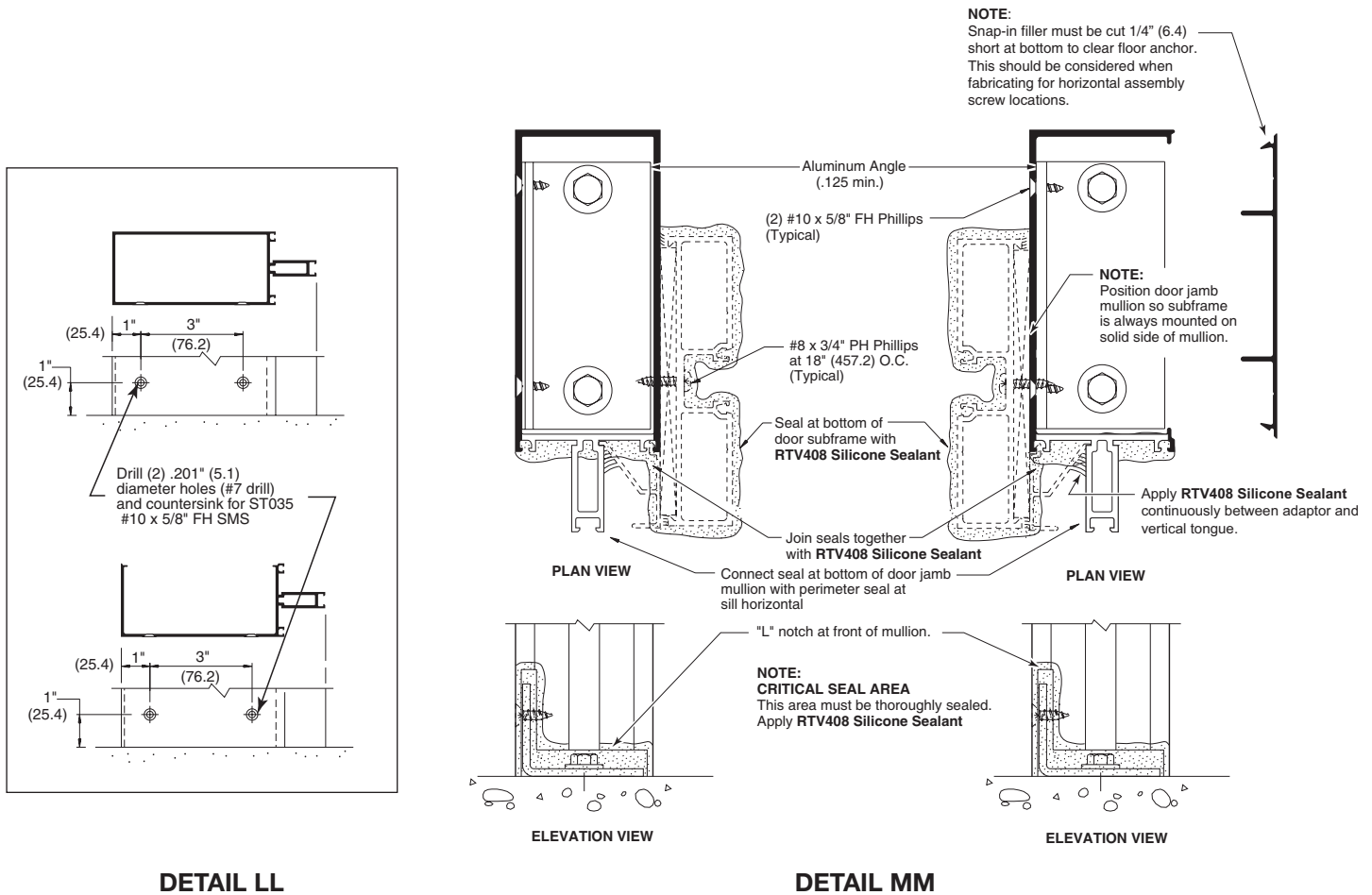

NOT TO SCALE



JOB SITE ESSENTIALS

Helpful Tools and Supplies for Installing CRL-U.S. Aluminum Entrances, Storefronts, Windows, and Curtain Wall Systems



CRL 95C Silicone Building Sealant



CRL RTV408 Neutral Cure Silicone



CRL 33S Acetic Cure Silicone Sealant



CRL M64 Smooth Texture Modified Polyurethane Construction Sealant



CRL M66 Grainy Texture Modified Polyurethane Construction Sealant



**CRL12:1 Ratio Strap Frame Caulking Gun
CAT. NO. GA1203**



CRL BOCBR Series Open Cell Backer Rod



**CRL Backer Rod Roller Tool
CAT. NO. SBRR**



**CRL 8" Vacuum Lifter
CAT. NO. S7950**



CRL Saint-Gobain/Norton V2100 Thermalbond® Structural Glazing Spacer Tape

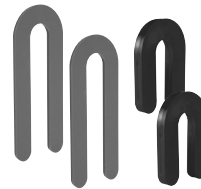

CRL PHS Series Plastic Horseshoe Shims



**CRL Digital Laser Level Tool
CAT. NO. 406065**



**CRL Cordless Screwdriver
CAT. NO. LD823**



**CRL Portable Miter Saw
10" CAT. NO. LS1040**

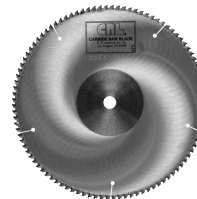

**CRL Nordic Carbide Saw Blade
CAT. NO. CSB10X100AX**

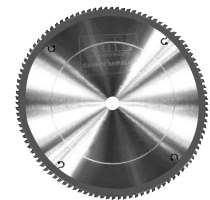

**CRL Cougar Carbide Saw Blade
CAT. NO. CT10X100**



**CRL Door Jack
CAT. NO. DJ1**



**CRL Complete Set of Seven All Stainless Steel Spatulas
CAT. NO. AB958G**



**CRL Portable Ladder
CAT. NO. 6206**



**CRL Hard Hat
CAT. NO. ES3452**



**CRL Soft-Face Power Hitter
CAT. NO. ST57532**

SERIES 4500 CURTAIN WALL



CRL Bond Breaker Tape



CRL Glass Cutters
CAT. NO. TC17B



CRL Running Pliers
CAT. NO. PPG1



CRL Utility Knife
CAT. NO. K82

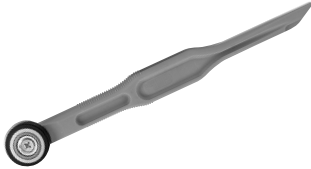

CRL Gasket Roller
CAT. NO. VR10

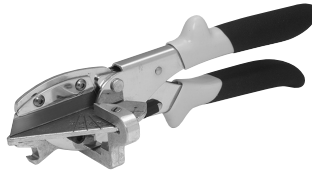

CRL Gasket Cutter
CAT. NO. MC80N



CRL Glass Cleaner
CAT. NO. 1973

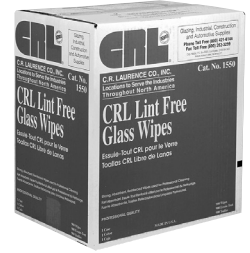

CRL Glass Wipes
CAT. NO. 1550

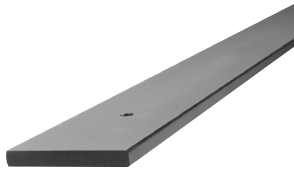

CRL 96" Phenolic Straight Edge
CAT. NO. SEP96



CRL Glazier's Rule Holder
CAT. NO. RH670



CRL Phenolic L Square
CAT. NO. L48



CRL Spring Clamp
CAT. NO. JC3202HT



CRL Tape Measure
CAT. NO. 54125



CRL Glass Marking Pencil
CAT. NO. GM44



CRL Belt Sander
CAT. NO. LD321



CRL Glass Grinding Belts
CAT. NO. CRL3X21120X



CRL Gloves
CAT. NO. KF1TL



CRL Utility Knife Blades
CAT. NO. 1992C



CRL Cordless Driver/Drill
CAT. NO. LD147



CRL All Terrain Dolly
CAT. NO. ATD1