

INSTALLATION INSTRUCTIONS

SERIES 2100/2200 CURTAIN WALL

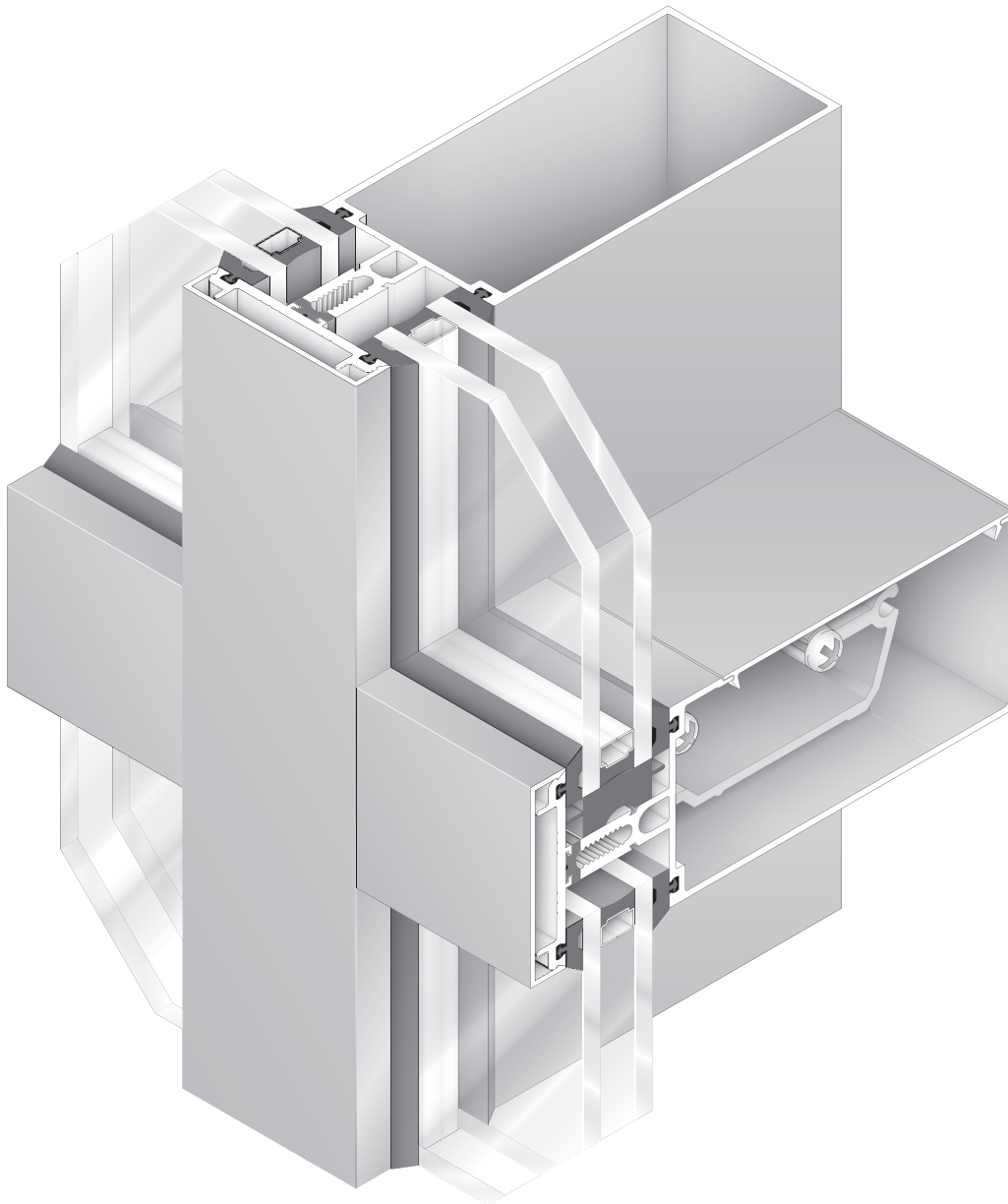

Phone: (800) 262-5151 • Fax: (866) 262-3299
crlaurence.com • usalum.com • crl-arch.com

HANDLING, STORAGE, AND PROTECTION OF ALUMINUM

The following precautions are recommended to protect the material against damage. Following these precautions will help ensure early acceptance of your products and workmanship.

A. HANDLE CAREFULLY.

All aluminum materials at job site must be stored in a safe place, well removed from possible damage by other trades. Cardboard wrapped or paper interleaved materials must be kept dry.

B. CHECK ARRIVING MATERIALS.

Check for quantity counts and keep records of where various materials are stored.

C. KEEP MATERIALS AWAY FROM WATER, MUD, AND SPRAY.

Prevent cement, plaster, or other materials from damaging the finish.

D. PROTECT THE MATERIALS AFTER ERECTION.

Protect erected frame with polyethylene or canvas splatter screen. Cement, plaster, terrazzo, other alkaline solutions, and acid based materials used to clean masonry are harmful to the finish. ***If any of these materials come in contact with the aluminum, immediately remove with water and mild soap.***

The rapidly changing technology within the architectural aluminum products industry demands that C.R. Laurence/U.S. Aluminum reserve the right to revise, discontinue, or change any product line, specification, or electronic media without prior written notice.

NOTE: Dimensions in parentheses () are millimeters unless otherwise noted.

GENERAL INSTALLATION NOTES

Recommended guidelines for all installations:

- 1. REVIEW CONTRACT DOCUMENTS.** Check shop drawings, installation instructions, architectural drawings, and shipping lists to become thoroughly familiar with the project. The shop drawings take precedence and include specific details for the project. Note any **field verified** notes on the shop drawings prior to installing. The installation instructions are of a general nature and cover most conditions.
- 2. INSTALLATION.** All materials are to be installed plumb, level, and true.
- 3. BENCH MARKS.** All work should start from bench marks and/or column lines as established by the architectural drawings and the general contractor with guaranteed accuracy. Working from these datum points and lines determine:
 - a) The plane of the wall in reference to offset lines provided on each floor.
 - b) The finish floor lines in reference to bench marks on the outer building columns.
 - c) Mullion spacing from both ends of masonry opening to prevent dimensional build-up of daylight opening.
- 4. STEEL ANCHORS.** Steel anchors that weld to steel structure are normally line set before mullions are hung. Outstanding leg of anchors must be at 90° to offset lines. Mullion space should be held to $\pm 1/32"$ (0.8). Anchor clips vary per job conditions. Follow approved shop drawings for size and location of clips.
- 5. FIELD WELDING.** All field welding must be adequately shielded to avoid any splatter on glass or aluminum. Results will be unsightly and/or structurally unsound. Advise general contractor and other trades accordingly. All field welds of steel anchors must receive touch-up paint (zinc chromate) to avoid rust.
- 6. SURROUNDING CONDITIONS.** Make certain that construction which will receive your materials is in accordance with the contract documents. If not, notify the general contractor in writing and resolve differences before proceeding with work.
- 7. ISOLATION OF ALUMINUM.** Aluminum to be placed in direct contact with uncured masonry or incompatible materials should be isolated with a heavy coat of zinc chromate or bituminous paint.
- 8. SEALANTS.** Sealants must be compatible with all materials with which they have contact, including other sealant surfaces. Consult with sealant manufacturer for recommendations relative to joint size, shelf life, compatibility, cleaning, priming, tooling, adhesion, etc. It is the responsibility of the **Glazing Contractor** to submit a statement from the sealant manufacturer indicating that glass and glazing materials have been tested for compatibility and adhesion with glazing sealants, and interpreting test results relative to material performance, including recommendations for primers and substrate preparation required to obtain adhesion. The chemical compatibility of all glazing materials and framing sealants with each other and with like materials used in glass fabrication must be established. ***This is required on every project.***
- 9. FASTENING.** Within the body of these instructions "fastening" means any method of securing one part to another or to adjacent materials. Only those fasteners used within the system are specified in these instructions. Due to the varying perimeter conditions and performance requirements, perimeter and anchor fasteners are not specified in these instructions. For perimeter and anchor fasteners refer to the shop drawings or consult the fastener supplier.
- 10. BUILDING CODES.** Due to the diversity in state/provincial, local, and federal laws and codes that govern the design and application of architectural products, it is the responsibility of the individual architect, owner, and installer to assure that products selected for use on projects comply with all the applicable building codes and laws. U.S. Aluminum exercises no control over the use or application of its products, glazing materials, and operating hardware, and assumes no responsibility thereof.
- 11. EXPANSION JOINTS.** Expansion joints and perimeter seals shown in these instructions and in the shop drawings are shown at normal size. Actual dimensions may vary due to perimeter conditions and/or difference in metal temperature between the time of fabrication and the time of installation. Gaps between expansion members should be based on temperature at time of installation.
- 12. WATER HOSE TEST.** As a representative amount of the wall has been glazed (500 square feet or 46.5 m²) a water hose test should be conducted in accordance with AAMA 501.2 specifications to check the installation. On all jobs the hose test should be repeated every 500 square feet (46.5 m²) during the glazing operation.
- 13. COORDINATION WITH OTHER TRADES.** Coordinate with the general contractor any sequence with other trades which offset curtain wall installation (i.e. fire proofing, back-up walls, partitions, ceilings, mechanical ducts, converters, etc.).
- 14. CARE AND MAINTENANCE.** Final cleaning of exposed aluminum surfaces should be done in accordance with AAMA 609.1 for anodized aluminum and 610.1 for painted aluminum.

TYPE "A" FABRICATION PROCEDURES

Shear Block Assembly

All tubular back members and shear block attachment of horizontal members allows for traditional stick type erection.

NOTE: For pre-assembled fabrication method, see page 14.

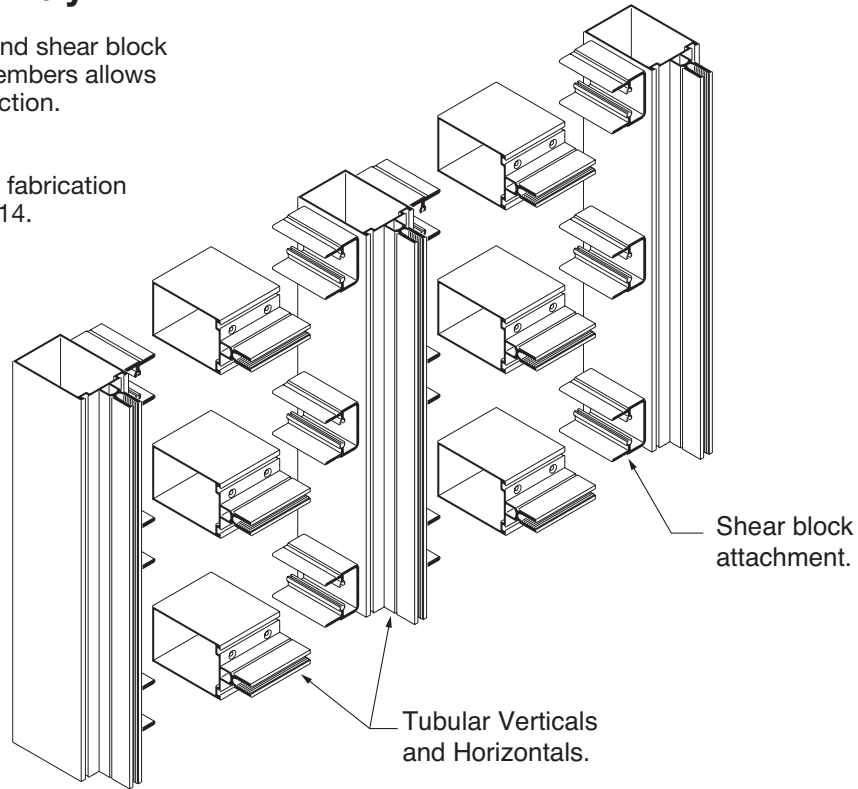

Screw Spine Assembly

With the addition of the two piece mullion, Series 2100/2200 can be completely fabricated and assembled complete with interior seals and end dams in the shop. Assembled panels can then be erected in the field quicker and with less labor, realizing a true cost savings.

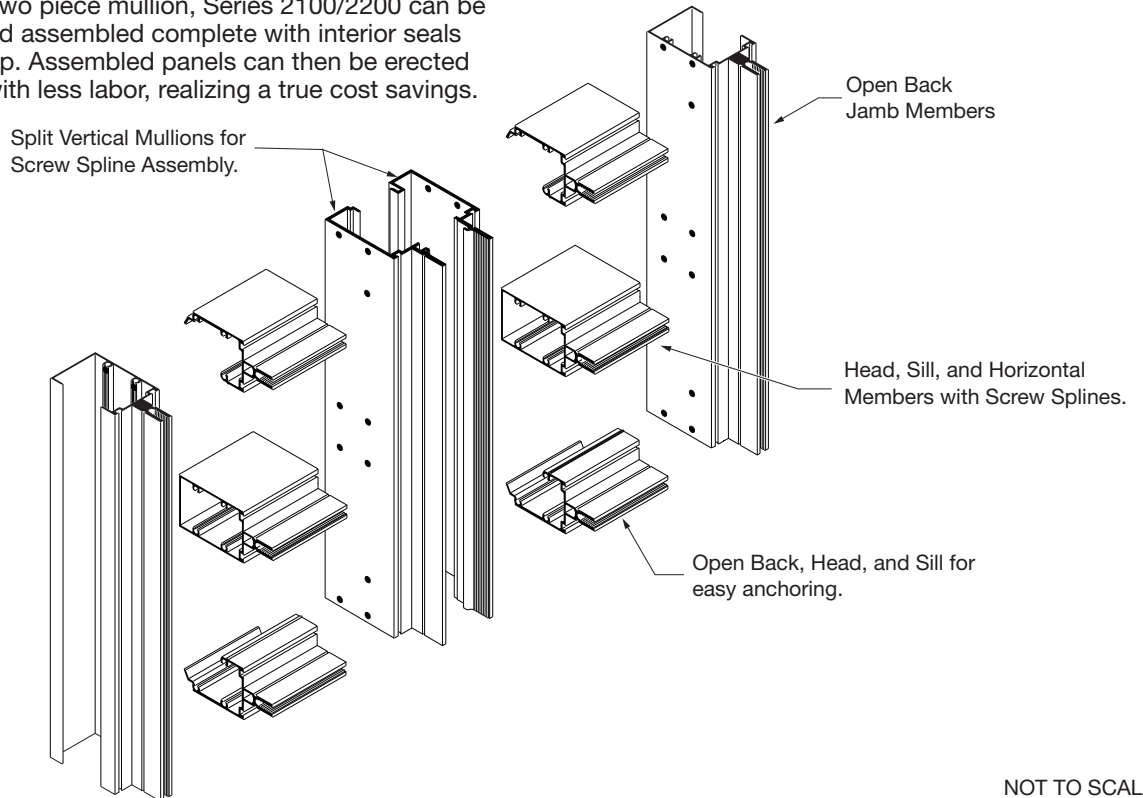

NOT TO SCALE

TYPE "A" FABRICATION PROCEDURES

Cutting Instructions for Shear Block and Screws Spline Assembly

Most of the details shown on these instructions are for 1" (25) Glazing 2-7/8" (73) back members. Details for 4" (102) and 5" (127) back members are similar.

1. Cut members to size:

- Vertical Back Members:** Rough Opening Minus Top and Bottom Clearances (Frame Height)
- Vertical Pressure Bars:** Frame Height Minus 1/4" (6)
- Vertical Face Covers:** Frame Height
- Vertical Transition Adapters:** D.L.O. Plus 1" (25)
- Horizontal Transition Adapters:** D.L.O. Minus 1/16" (2)
- Horizontal Back Members:** D.L.O. Plus 1/32" (0.8)
- Horizontal Pressure Bars:** D.L.O. Minus 1/4" (6)
- SSG Pressure Bars:** Frame Width Minus 4-1/4" (108)
- Horizontal Face Members:** D.L.O. Minus 1/32" (0.8)
- Horizontal Trim Members:** D.L.O. Minus 1/32" (0.8)
- Jamb Perimeter Fillers:** Frame Height Minus 1/4" (6)
- Head and Sill Perimeter Fillers:** D.L.O. Minus 1/8" (3)

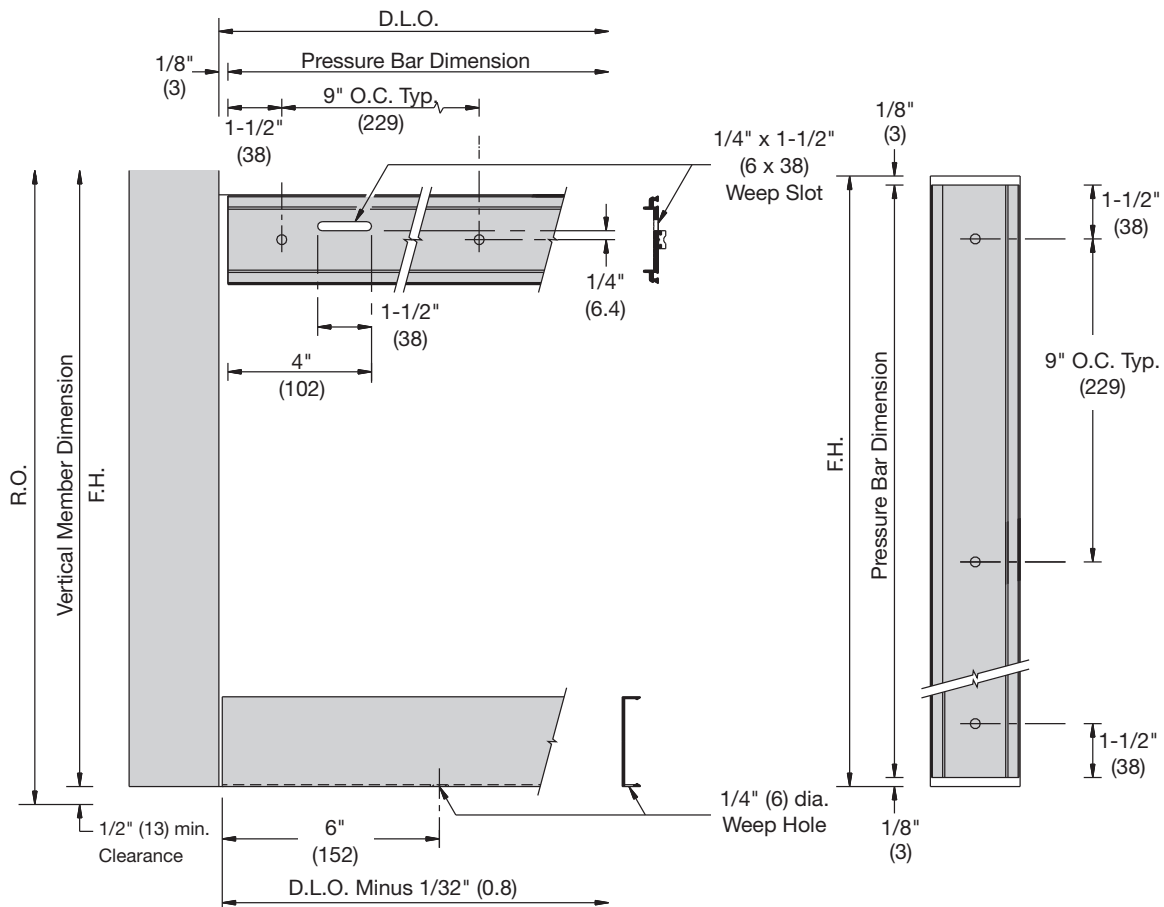

DETAIL A

NOT TO SCALE

DRILL JIG PREPARATION

Shear Block Fabrication

- Fabricate verticals for horizontal members. Mark on verticals the location of horizontal members and drill holes for shear blocks (See **DETAIL B**). Visit usalum.com for additional information.

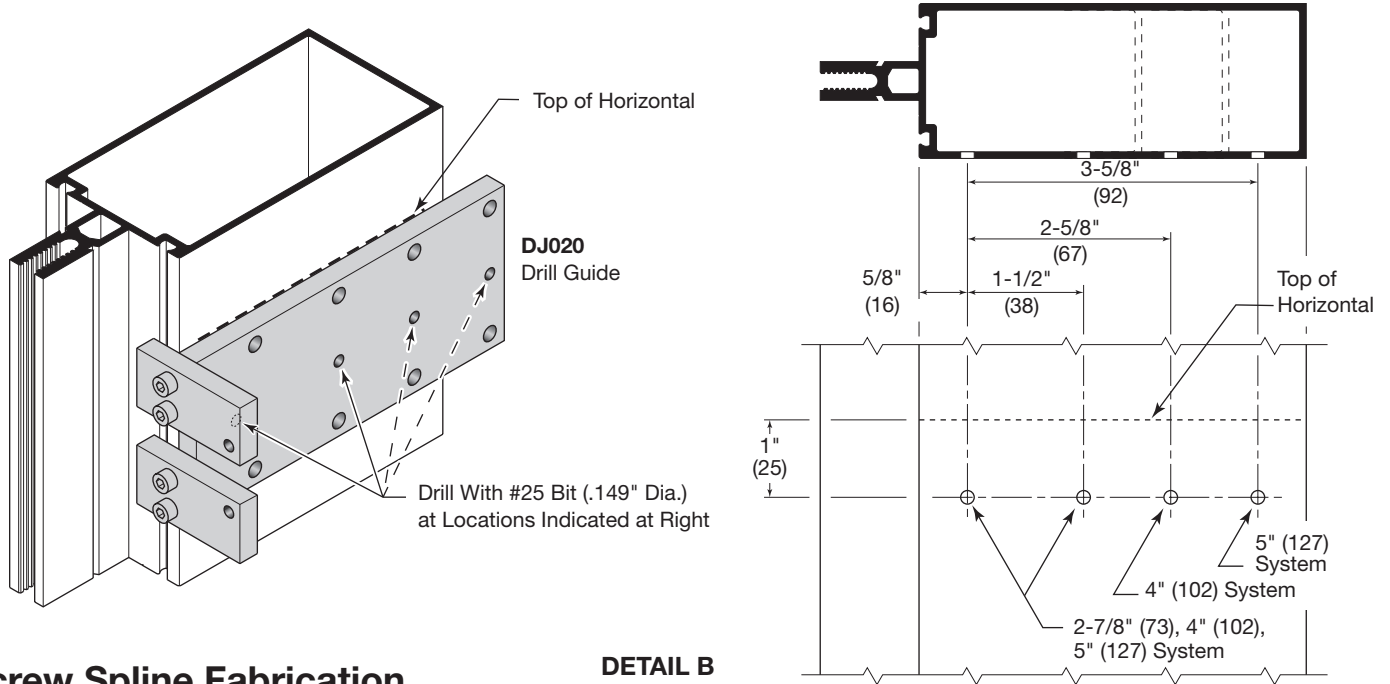

Screw Spine Fabrication

- Fabricate two piece verticals for horizontal members. Mark on verticals the location of horizontal members and drill holes for screw spine (See **DETAIL C**).

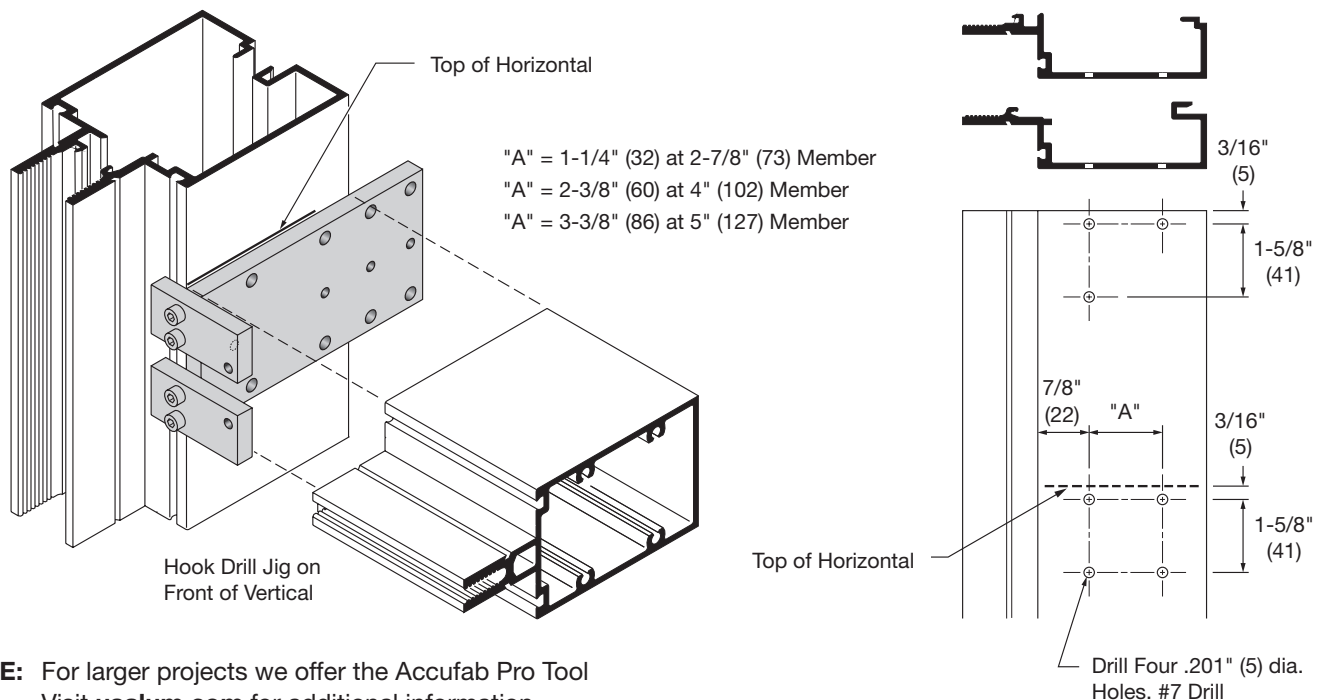

NOTE: For larger projects we offer the Accufab Pro Tool Visit usalum.com for additional information.

NOT TO SCALE

Structural Silicone Fabrication

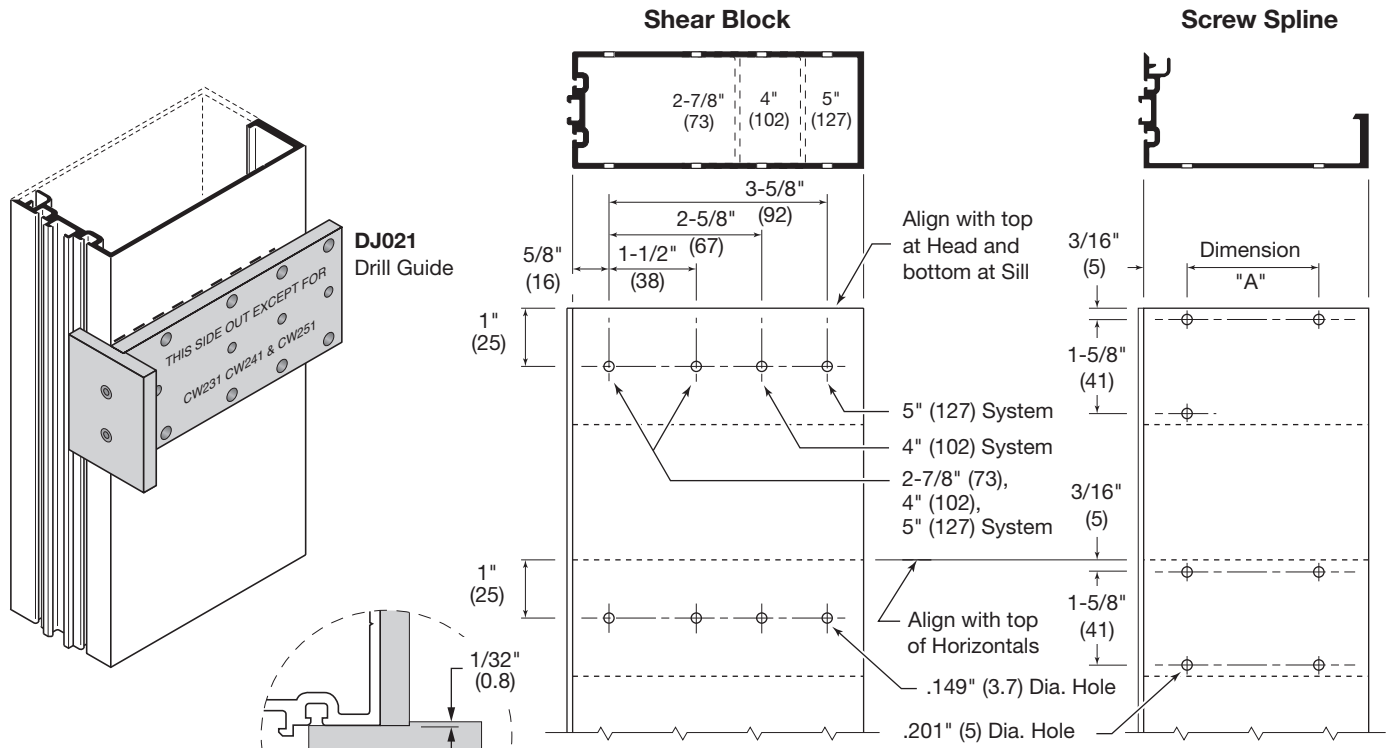

DETAIL D

"A" = 1-1/4" (32) at 2-7/8" (73) Member
 "A" = 2-3/8" (60) at 4" (102) Member
 "A" = 3-3/8" (86) at 5" (127) Member

- Fabricate structural silicone verticals for horizontal members as shown in **DETAIL D** and **E**.

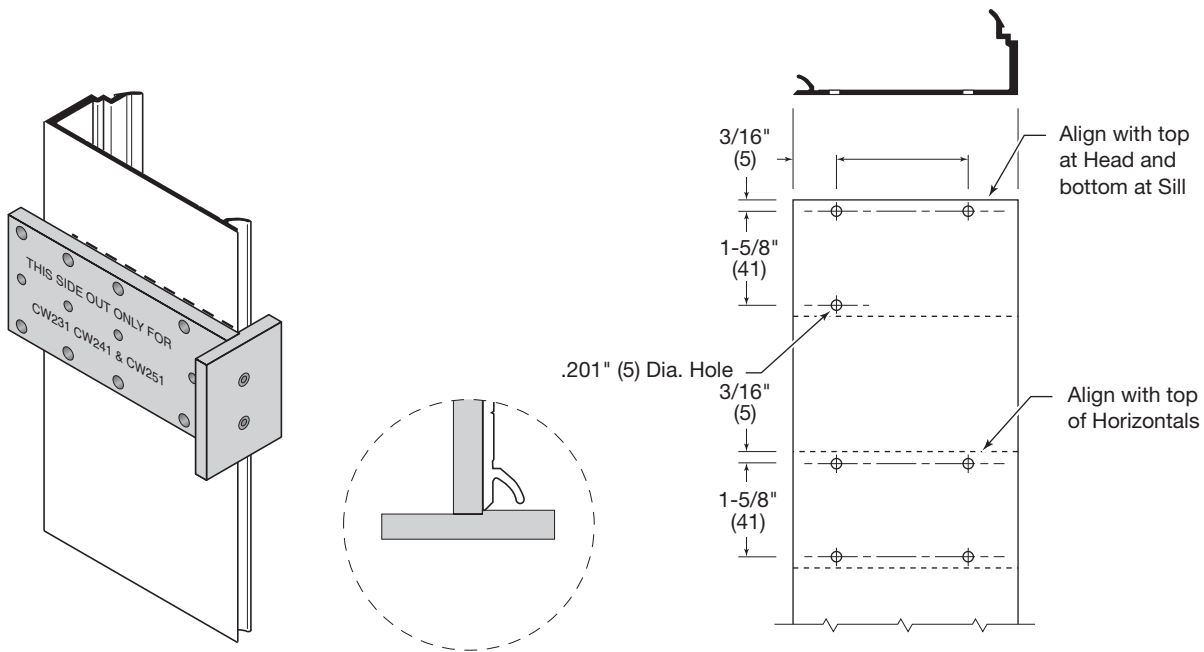

DETAIL E

NOT TO SCALE

For Shear Block Assembly

- Fabricate ends of horizontal members for shear block attachment screws. See **DETAIL F** for drill usage.

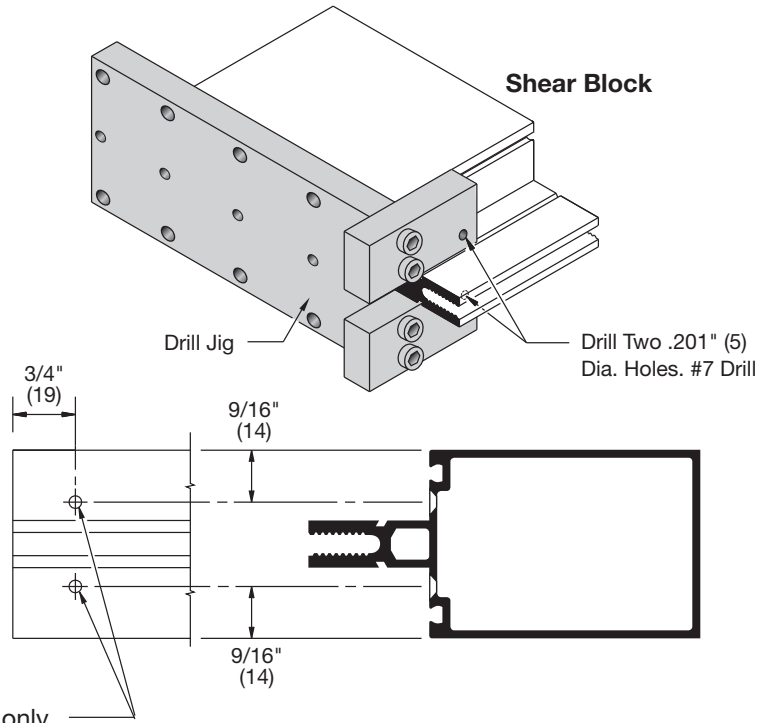

NOTE: Drill lower hole only at head and upper hole only at sill. Countersink for a #8 FHSMS

DETAIL F

- Notch head and sill members as shown. See **DETAIL G**.

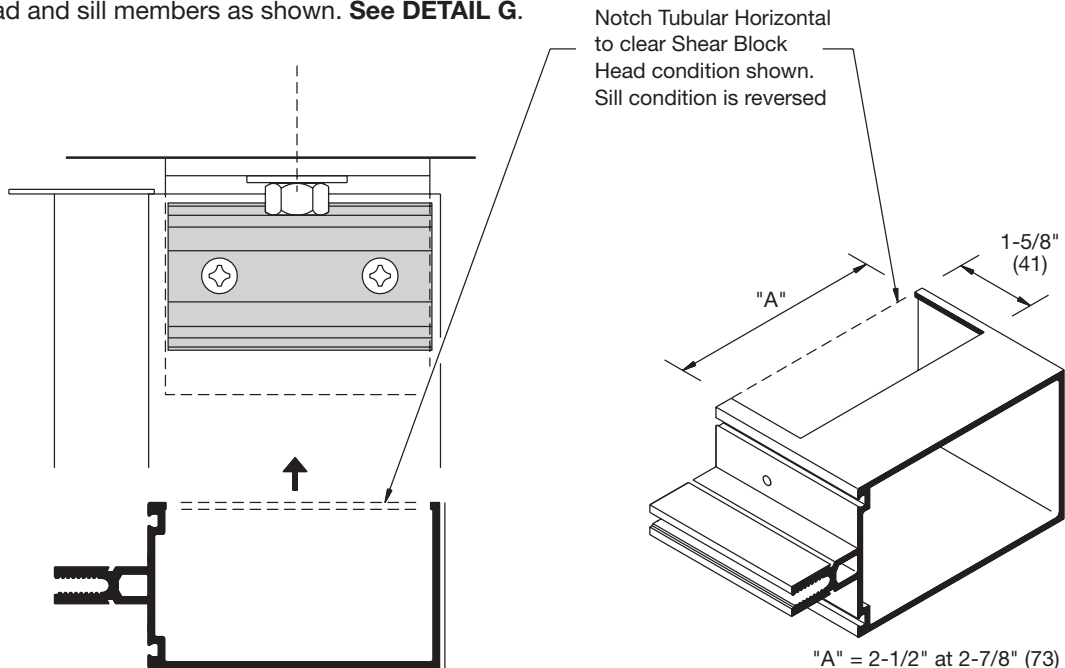

DETAIL G

"A" = 2-1/2" at 2-7/8" (73) Back Member
 "A" = 3-5/8" at 4" (102) Back Member
 "A" = 4-5/8" at 5" (127) Back Member

NOT TO SCALE

SERIES 2100/2200 CURTAIN WALL

7. Notch intermediate horizontal for last bay installation only. See **DETAIL H**.

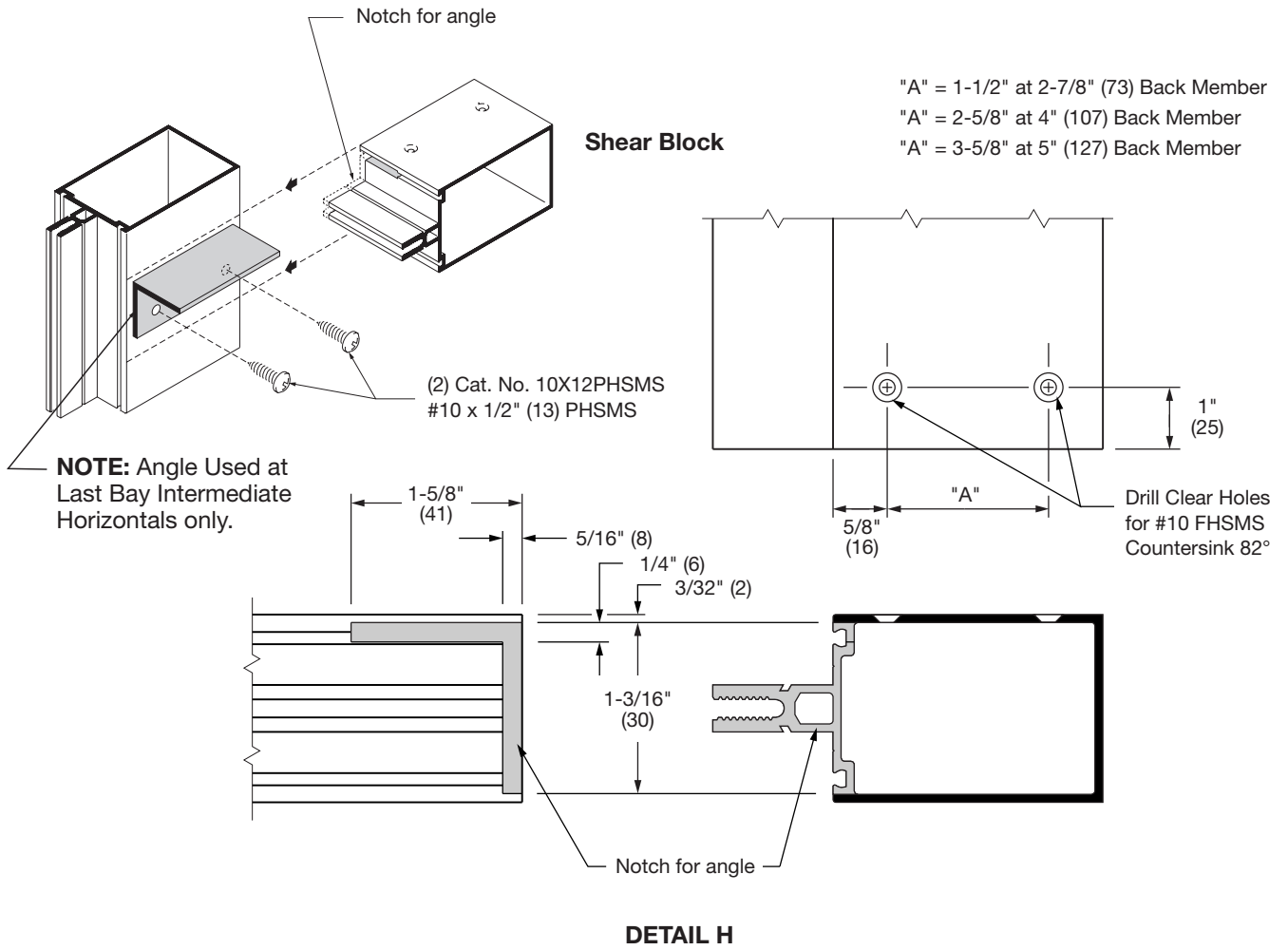

8. Drill 1/4" (6) dia. holes in bottom of horizontal face covers 6" (152) from each end.

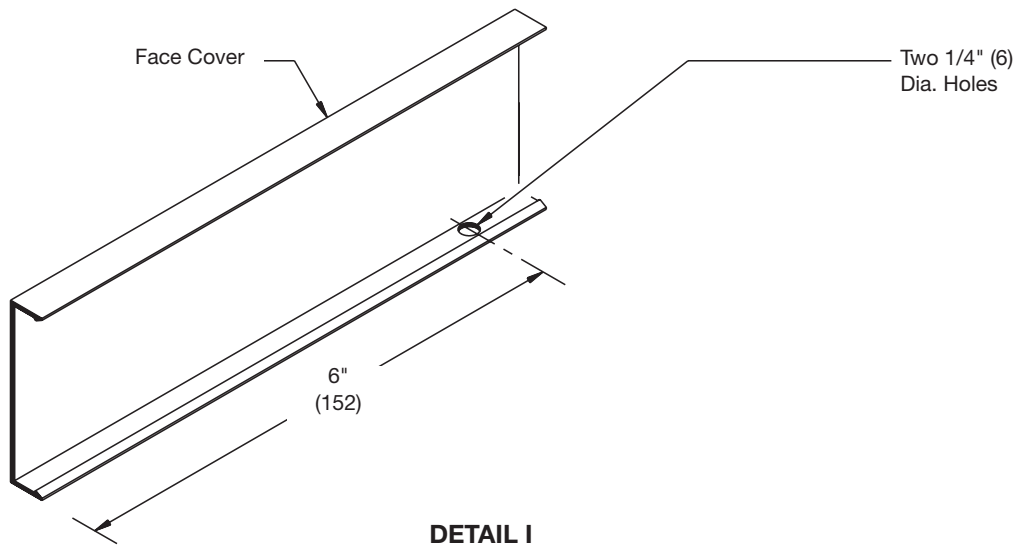

NOT TO SCALE

For Screw Spline Assembly

1. Assemble panels. Apply closer plates to tops and bottoms of vertical mullions. **See Page 12 DETAIL O.** Place jamb panel into opening, shim, plumb, level and true. Anchor head and sill. **See approved shop drawings for correct anchor type and size. See DETAIL L.**

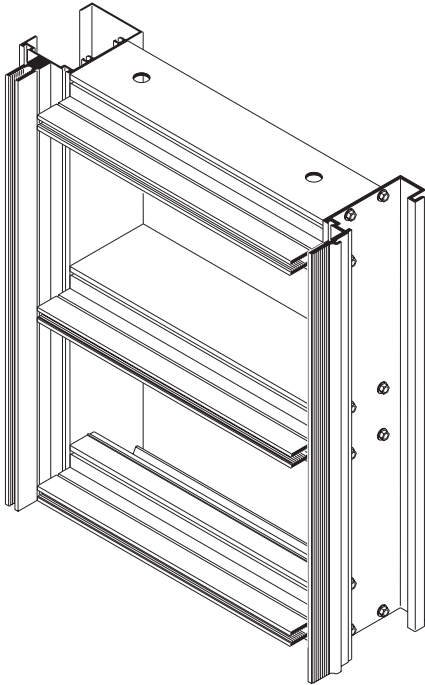

Allow for expansion with shoulder bolts or Pipe Sleeves as shown on approved shop drawings.

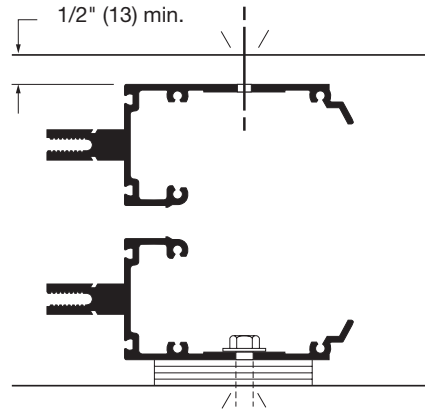

DETAIL L

2. Place next panel into opening, engage with jamb panel, and shim flush with bottom of jamb panel. Attach vertical mullions with screws at horizontal/vertical intersections and one at top and bottom. Be certain that mullion halves are flush at the bottom with each other. Complete this procedure until all panels are installed. **See DETAIL M.**

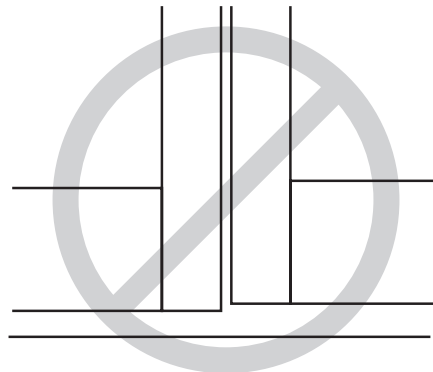
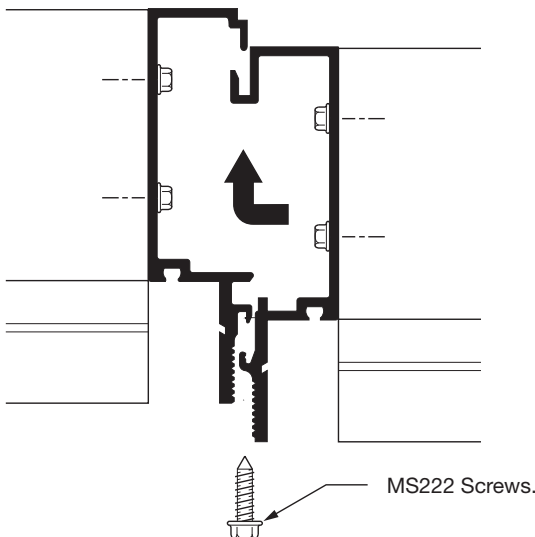

DETAIL M

NOT TO SCALE

Installation Procedure Screw Spline or Shear Block Assembly

3. Apply Backer Rod and Sealant along entire perimeter. Install Perimeter Fillers.

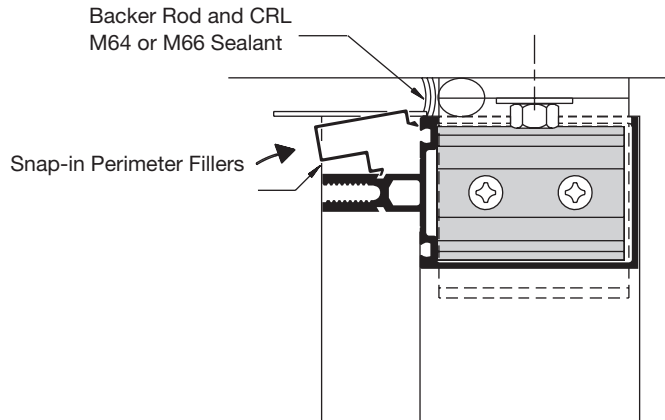

DETAIL N

Installation Procedure for Shear Block Assembly

1. Apply Closure Plates to vertical mullions as shown in DETAIL O.

NOTE: Shear Blocks not shown for clarity.

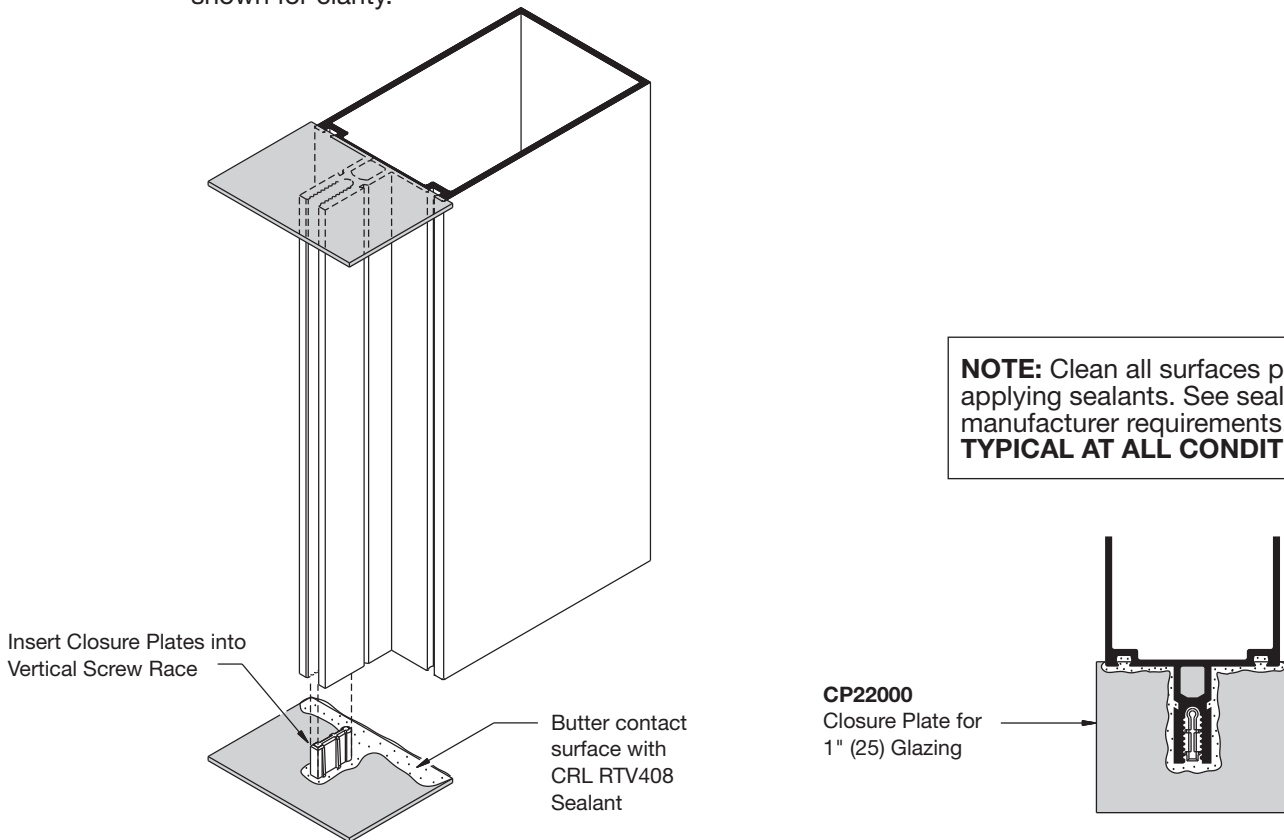

DETAIL O

NOT TO SCALE

Installation Procedure for Shear Block Assembly

- Slide anchors into ends of vertical mullions. If shims are required place them directly under each side of vertical for proper load distribution. Secure anchors to structure plumb, level, and true. See approved shop drawings for anchor bolt type and size.

NOTE: Aluminum anchors must be isolated from dissimilar materials. Typical at top and bottom

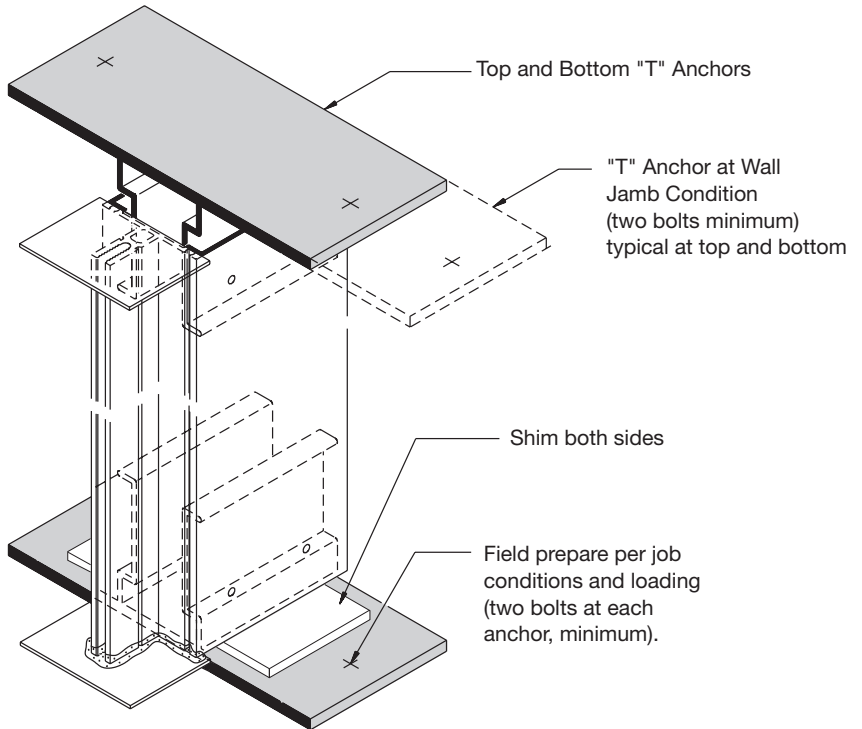

NOTE: Shear Blocks not shown for clarity.

DETAIL P

- Attach Shear Blocks to verticals with screws provided.
NOTE: Tubular intermediate horizontals must be installed per bay along with verticals. Head and sill members are notched. See Page 8. Last bay intermediate horizontal is notched.
- Install backer rod, sealant and perimeter fillers along entire perimeter of opening. **See DETAIL N on Page 12.**

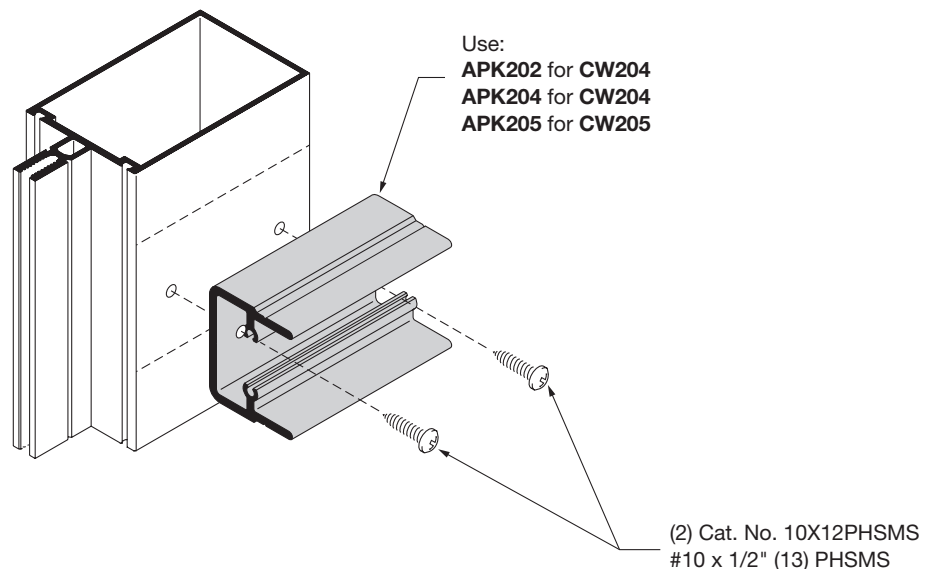

DETAIL Q

NOT TO SCALE

TYPE "B" FABRICATION PROCEDURES

Pre-assembled Multi-Lite Assembly

This assembly method allows for jamb members to run through and intermediate verticals to butt between and be attached through head and sill members as shown below. Intermediate horizontal members are attached with shear blocks. This type assembly is best utilized when the complete frame can be assembled and placed in the opening.

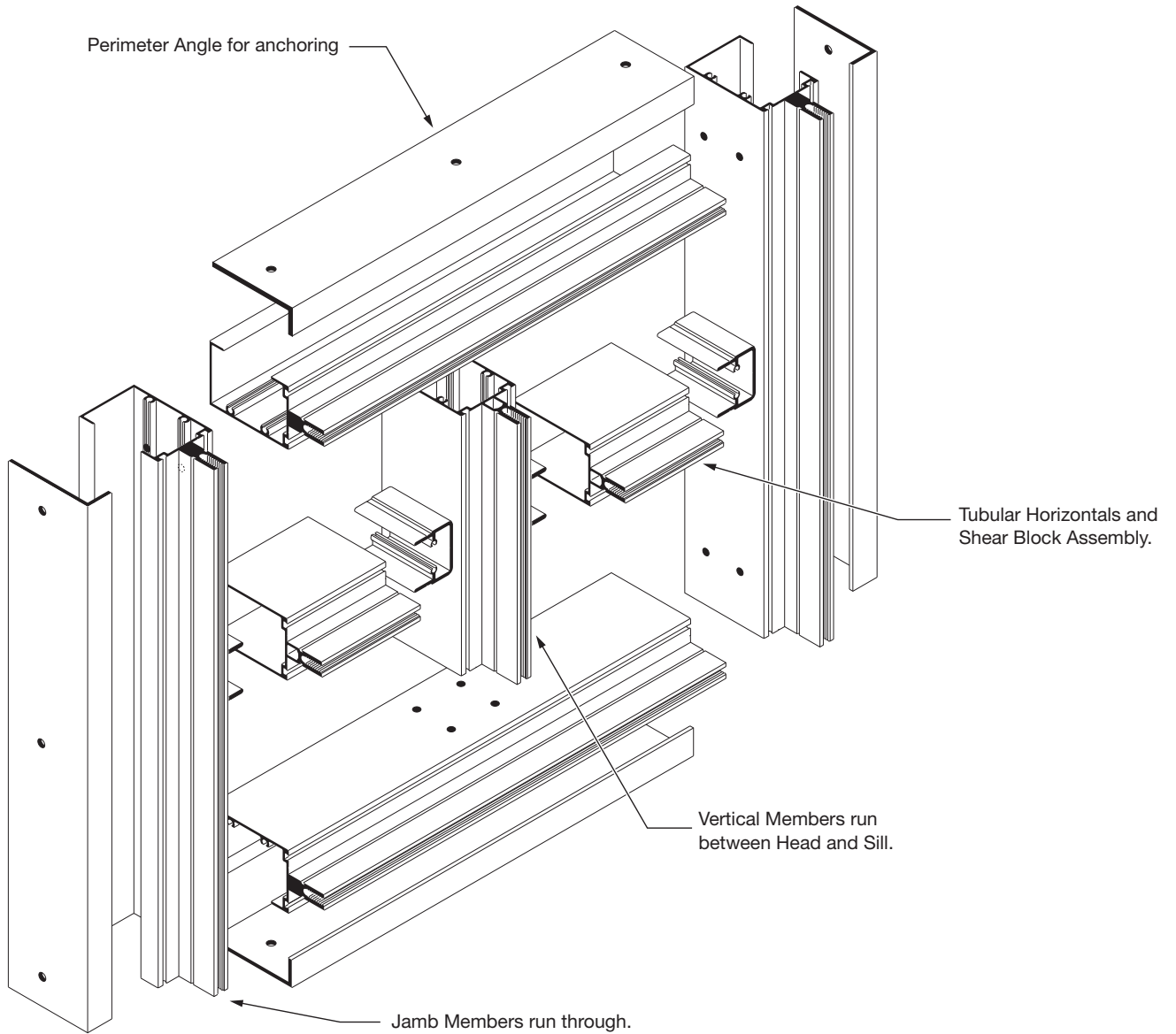

DETAIL R

NOT TO SCALE

TYPE "B" FABRICATION PROCEDURES

Cutting Instructions for Pre-assembled Multi-Lite Assembly

1. Cut members to size:

Wall Jamb Back Member:	Rough Opening Minus Top and Bottom Clearances (Frame Height)
Wall Jamb Pressure Bar:	F.H. Minus 1/4" (6)
Wall Jamb Face Cover:	Frame Height
Wall Jamb Anchor Angle:	Frame Height
Intermediate Vertical Back Member:	Frame Height minus 4" (102) (+ 0" - 1/32")
Intermediate Vertical Pressure Bar:	Frame Height minus 4-1/4" (108)
Intermediate Vertical Cover:	D.L.O. (+ 0" - 1/32") (0.8)
Intermediate Horizontal Back Member:	D.L.O. (+ 0" - 1/32") (0.8)
Intermediate Horizontal Pressure Bar:	D.L.O. Minus 1/4" (6)
Intermediate Horizontal Cover:	D.L.O. Minus 1/32" (0.8)
Head and Sill Back Member:	Frame Width Minus 4" (102)
Head and Sill Pressure Bar:	Frame Width Minus 4-1/4" (108)
Head and Sill Cover:	Frame Width Minus 4" (102) (+ 0" - 1/32")
Head and Sill Filler:	Frame Width Minus 4-1/8" (105)
Head and Sill Anchor Angle:	Frame Width Plus 1/2" (13)
Vertical Transition Adapter:	D.L.O. Plus 1" (25)
Horizontal Transition Adapter:	D.L.O. Minus 1/8" (3)

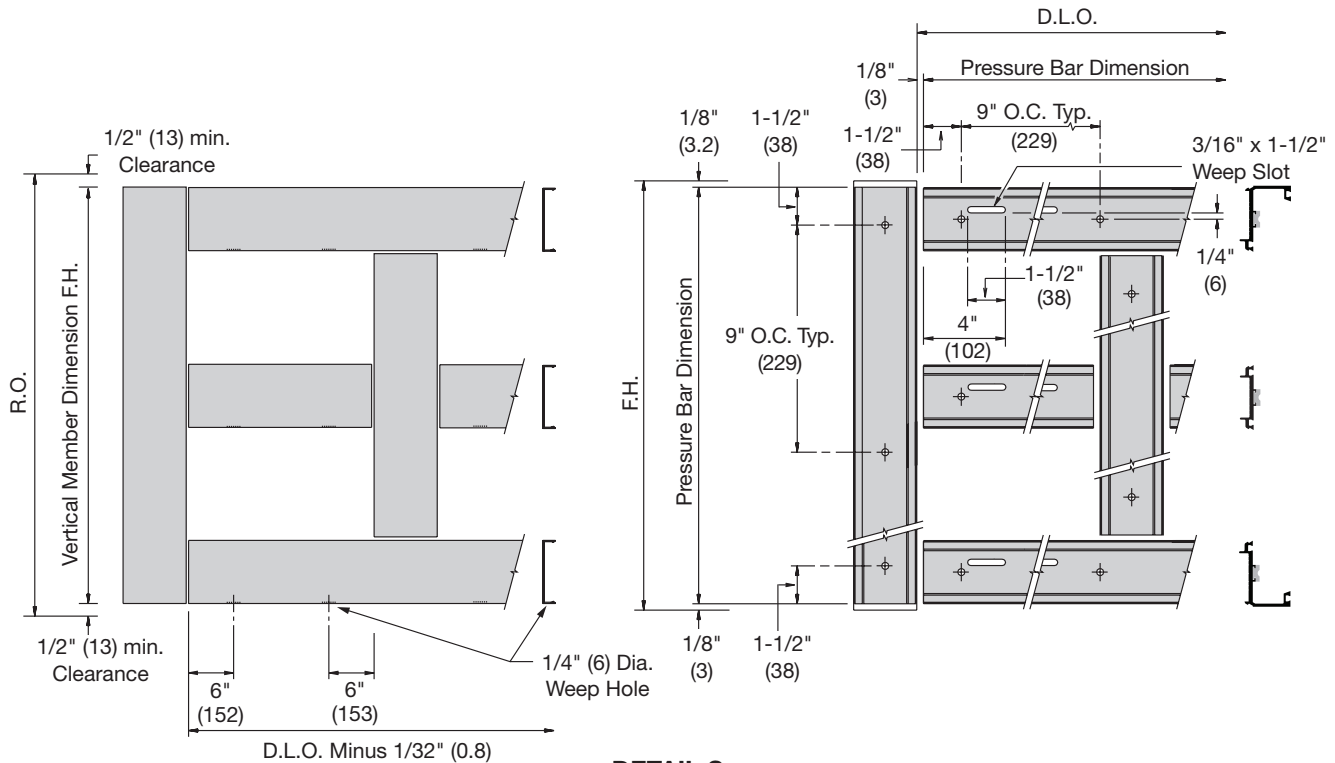

DETAIL S

NOT TO SCALE

SERIES 2100/2200 CURTAIN WALL

2. Mark on verticals locations of horizontal members and drill holes for shear blocks or screw splines.

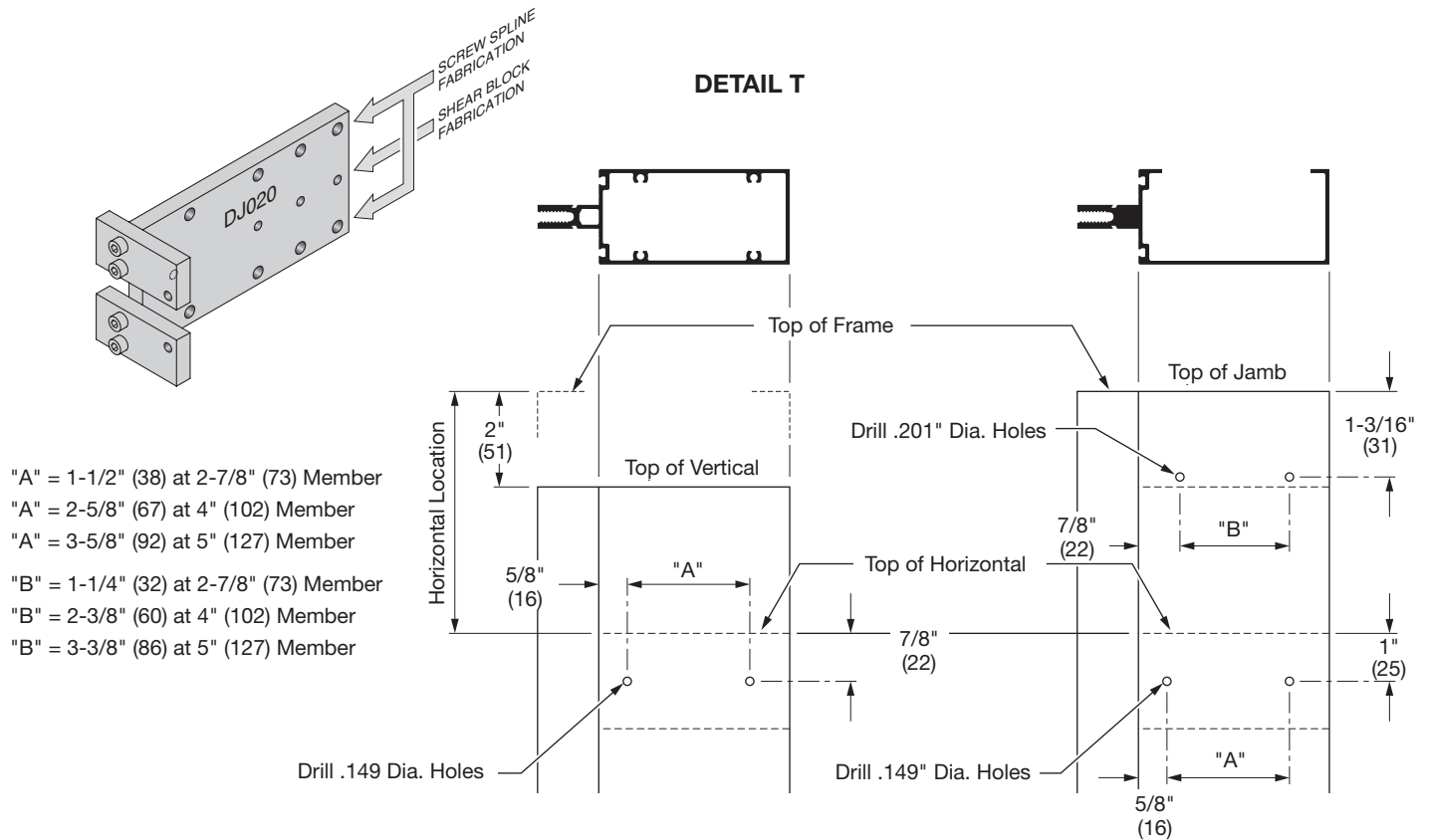

3. Mark on head and sill members locations of intermediate verticals and drill holes.
4. Fabricate intermediate horizontal members for shear block attachment screws. **See DETAIL F on Page 8.**

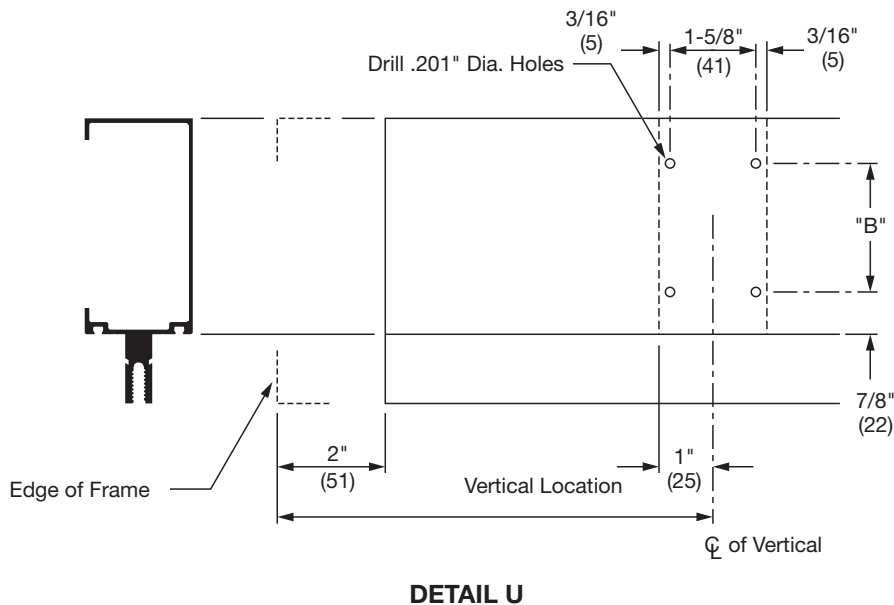

5. Fabricate horizontal pressure bars for slots and attachment holes. **See DETAIL J on Page 10.**

NOT TO SCALE

SERIES 2100/2200 CURTAIN WALL

6. Notch top and bottom of jamb members as **shown in DETAIL V** to clear perimeter angle. Top shown, bottom similar.

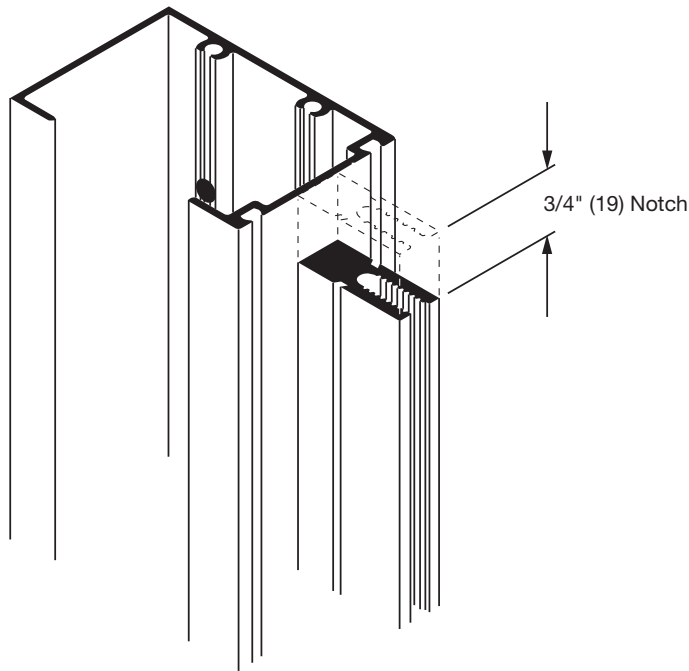

DETAIL V

7. Fabricate perimeter angle as **shown in DETAIL W**. Head portion of anchor does not receive holes on 3/4" (19) leg. Do not attach head member to anchor at head.

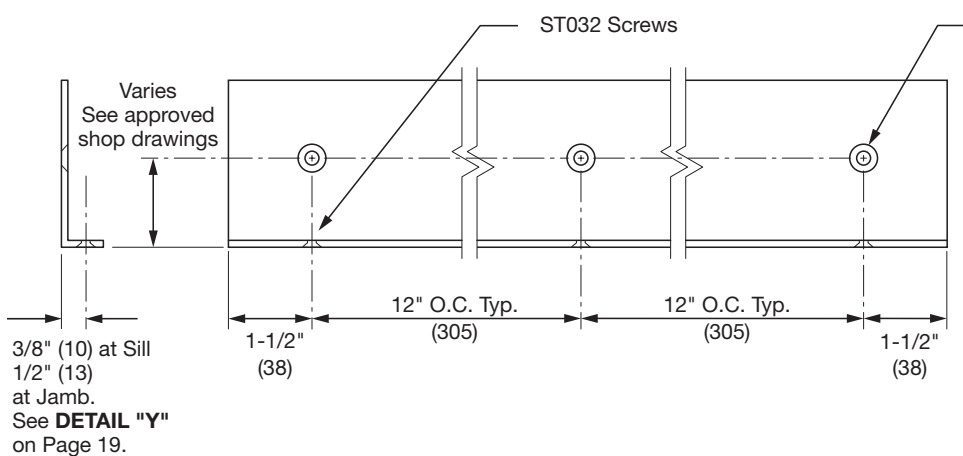

DETAIL W

Diameter of holes varies per anchor size. See approved shop drawings.

NOTE: Countersink Holes to allow frame installation.

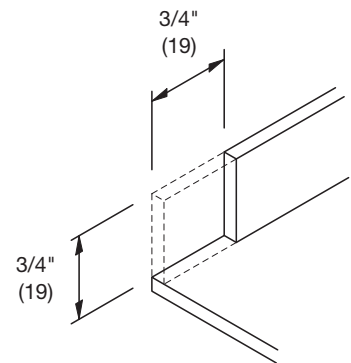

NOT TO SCALE

ASSEMBLY PROCEDURE

Installation Procedure For Pre-assembled Multi-Lite Assembly

1. Attach shear blocks to mullion and jambs as **shown in DETAIL X**.

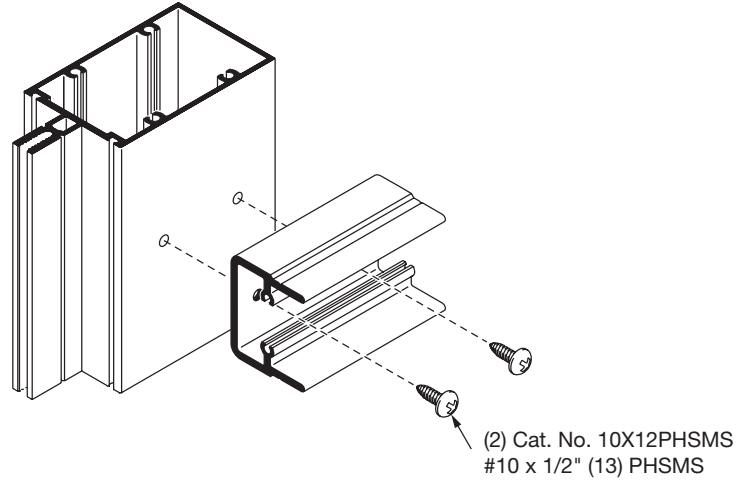

DETAIL X

2. Assemble frame as **shown in DETAIL Y**.

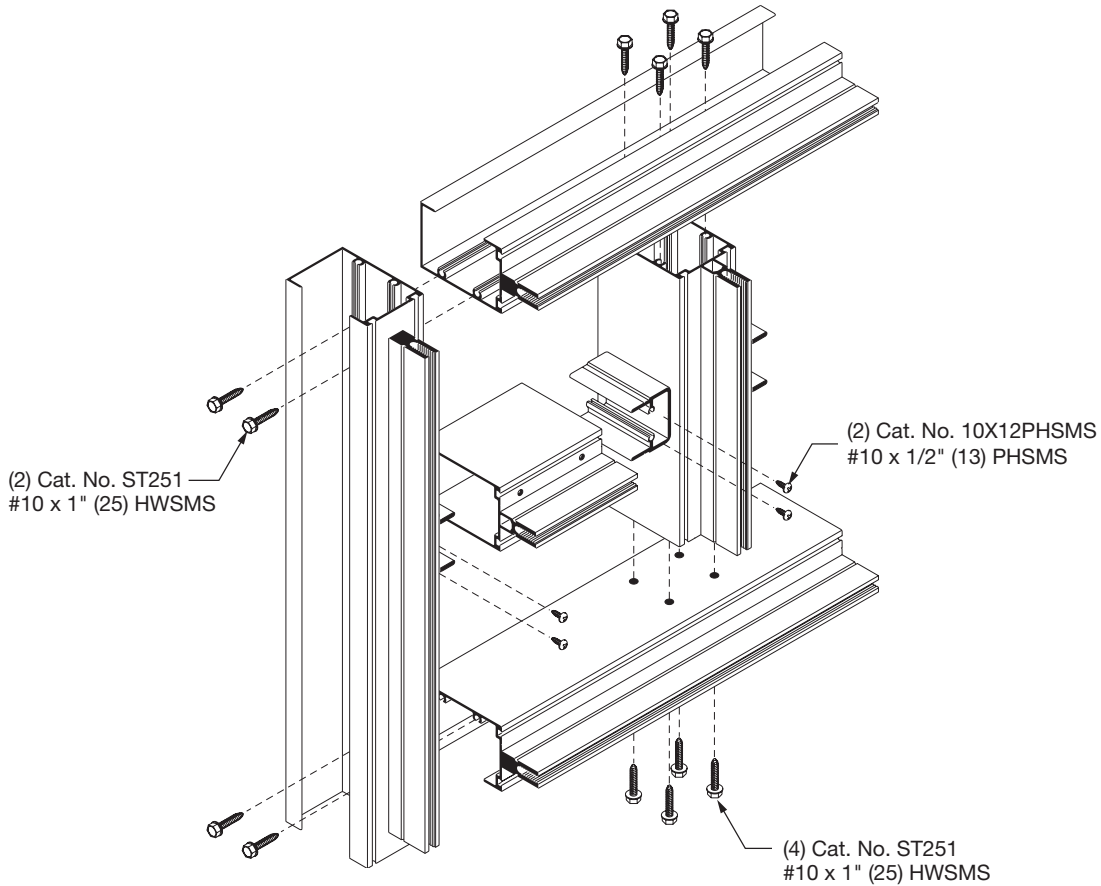

DETAIL Y

NOT TO SCALE

ASSEMBLY PROCEDURE

3. Install perimeter angle into opening. See approved shop drawings for proper anchor bolt and size. Apply sealant to areas as **shown in DETAIL Z**.

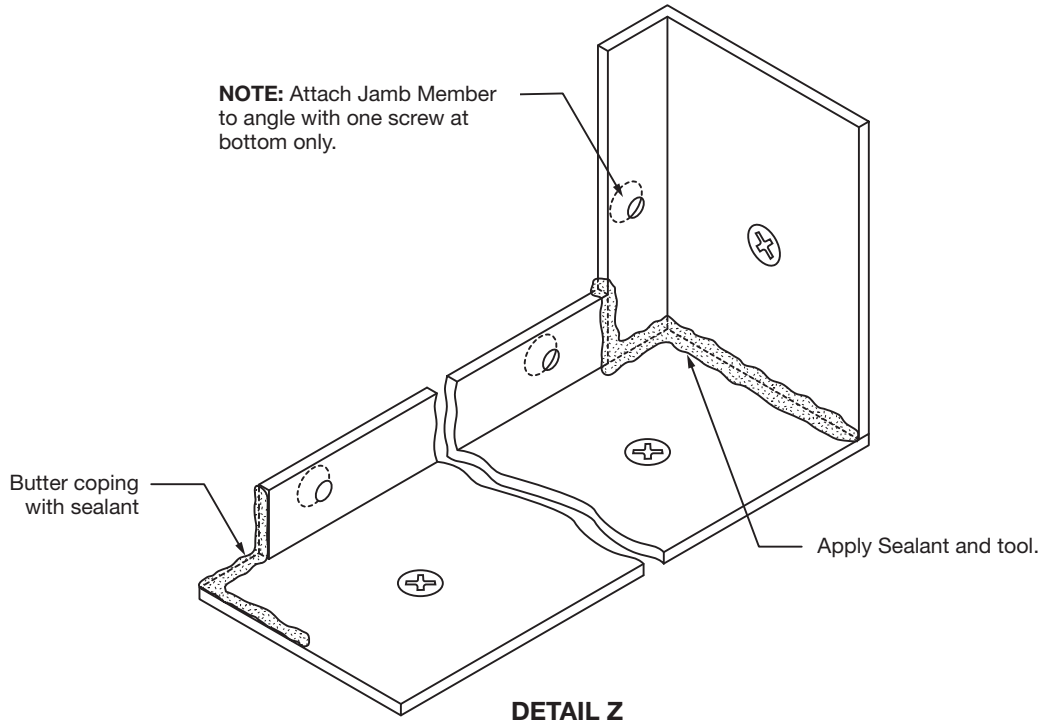

4. Install frame into opening plumb, level and true. Attach frame to angle at sill and one screw at bottom of jambs with Cat. No. ST035 #10 x 5/8" (16) screws, 12" on center. Attach a piece of the perimeter pressure bar at the head to temporarily hold the frame in place.

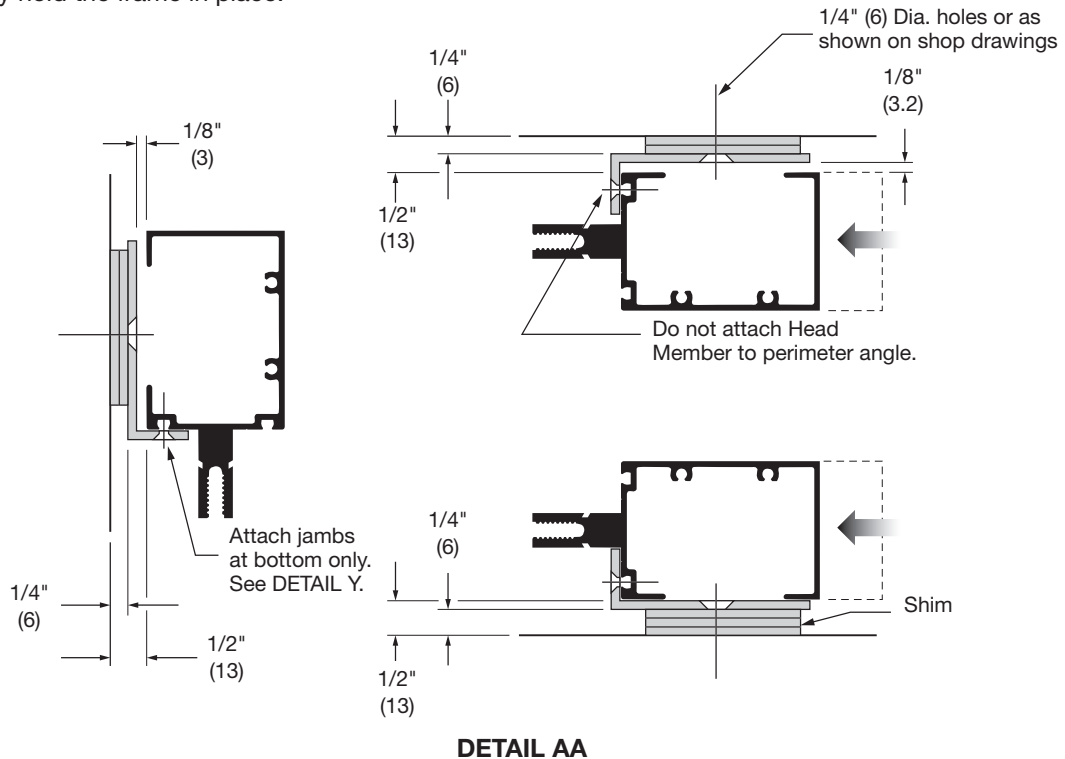

NOT TO SCALE

FRAME SEALANT PROCEDURE

1. Apply CRL RTV408 Seal joint at horizontal and vertical intersection. Seal over heads of screws in the glazing pockets.
See DETAIL BB
2. Apply sealant at the three contact areas of end dams. Fill the vertical gasket reglet with sealant at the end dam location.
3. Slide End Dams into place. **NOTE:** End Dams occur at head and sill also.

NOTE: CONSULT SEALANT MANUFACTURER FOR PROPER CLEANING AND PRIMING RECOMMENDATIONS.

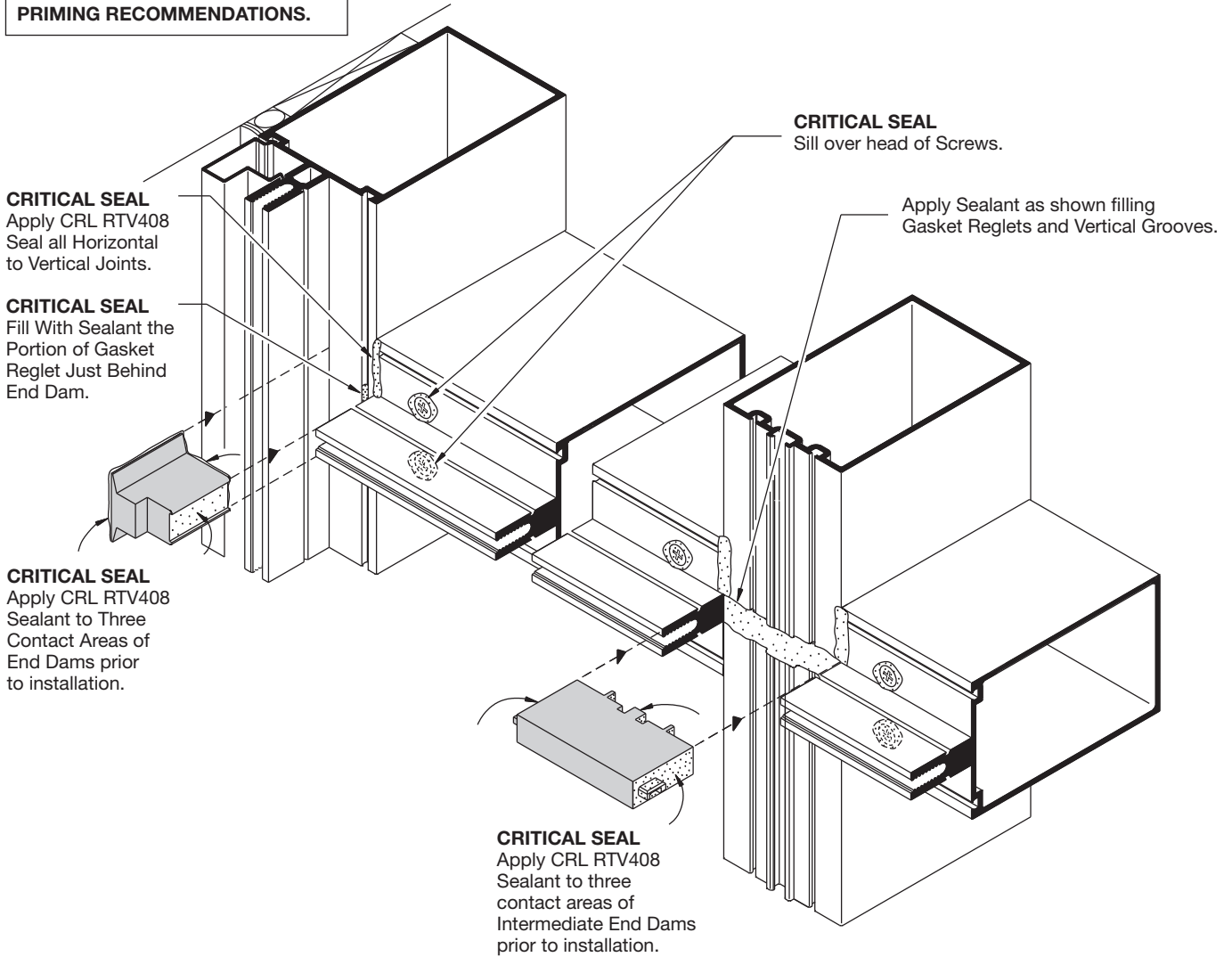

DETAIL BB

NOT TO SCALE

GLAZING

GLASS SIZES (Captured)

GLASS WIDTH & HEIGHT = DAYLIGHT OPENING + 1" (25)

GLASS SIZES (Structural Silicone Glazed)

GLASS HEIGHT = DAYLIGHT OPENING + 1" (25)

GLASS WIDTH = DAYLIGHT OPENING + GLASS BITES

NOTE: These formulas do not take into account glass tolerances. Consult glass manufacturer before ordering glass.

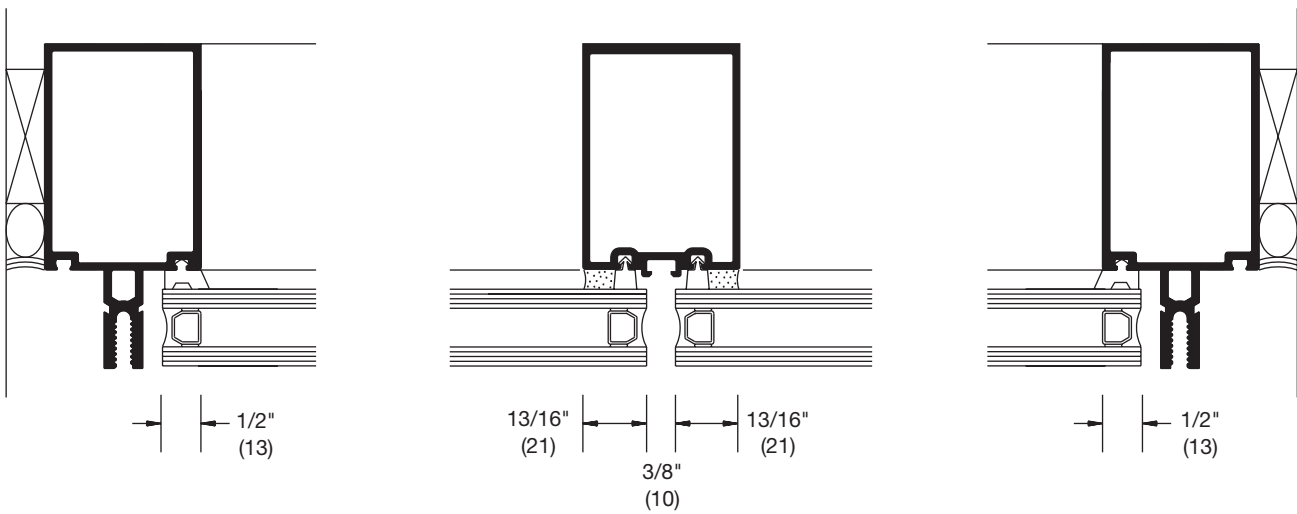

DETAIL CC

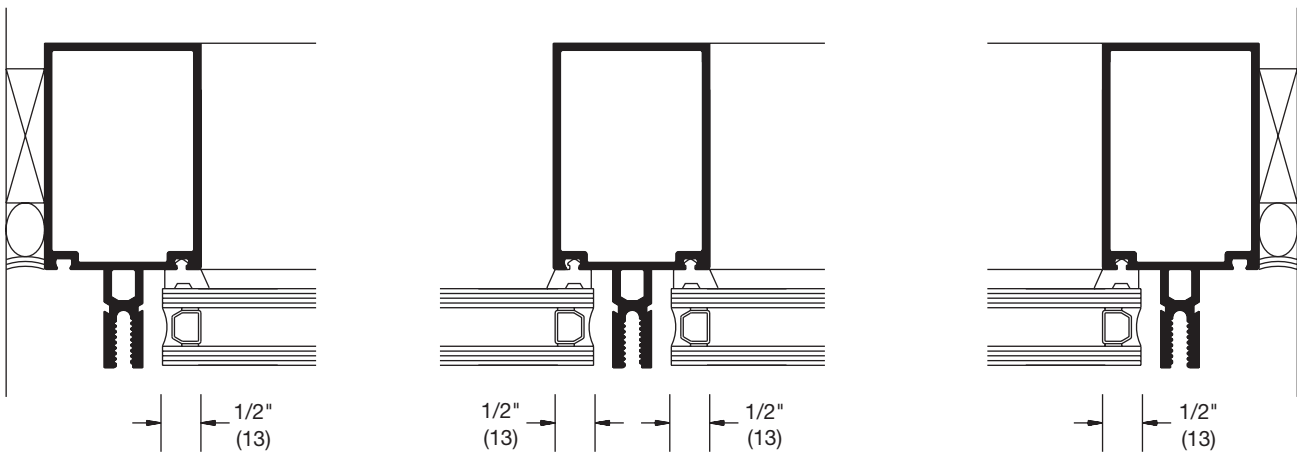

DETAIL DD

NOT TO SCALE

GLAZING

Remove gaskets from carton and lay flat in a clean, dry area in order to recover shape. Allow gaskets to relax at least two hours at temperatures above 50°F (10°C). Glaze with gaskets above 40°F (4.44°C). If necessary warm gaskets in a hot box before installing.

Use **NP430** dense gasket at exterior and **NP420** sponge at interior.

1. Cut gaskets allowing 1/8" (3) extra length per foot of extrusion to allow for shrinkage.
Vertical gaskets on mullion run past horizontal gaskets by 5/8" (16).
Horizontal gaskets butt against vertical gaskets.
2. Install back gaskets into vertical and horizontal members and front gaskets into pressure bars. Horizontal pressure bar gaskets should extend 1/8" (3) beyond each end of the extrusions. Vertical pressure bar gaskets run continuous.
3. Position two setting blocks for each glass lite as directed by the deadload charts and shop drawings.
4. Apply silicone to vertical mullion and press on two side blocks per glass lite, at approximately mid-height of glass. **See DETAIL EE.**

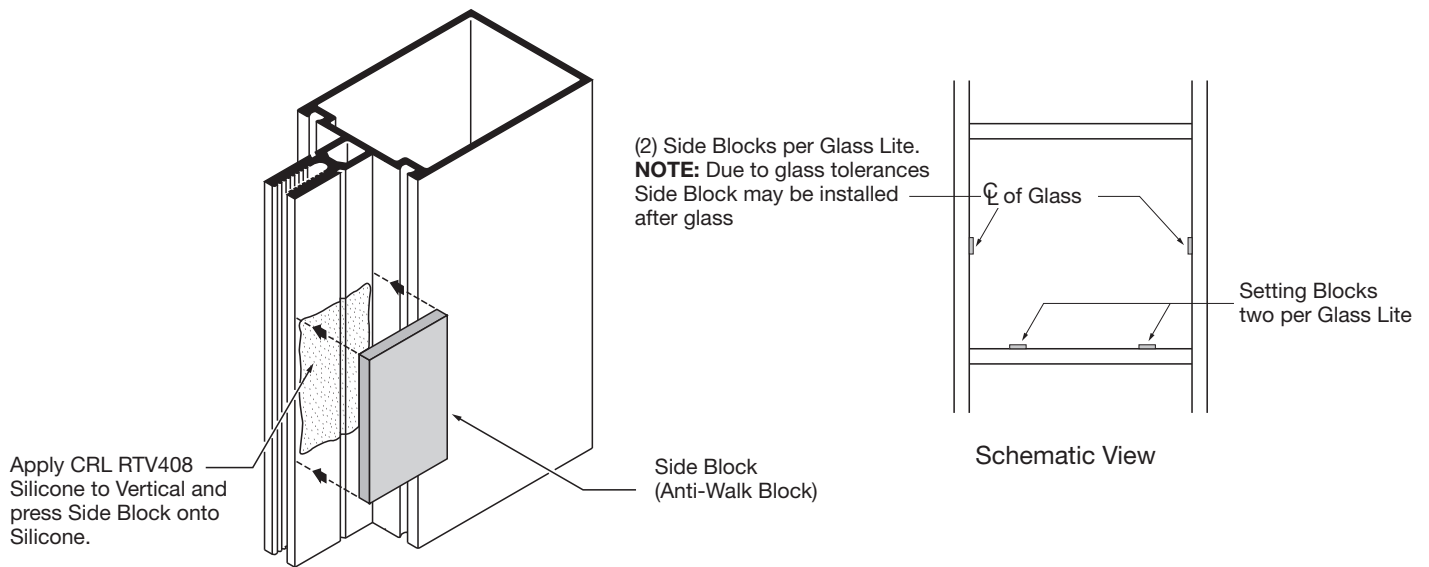

DETAIL EE

5. Apply bead of sealant at interior gaskets corners 2" (51) in each direction. **See DETAIL FF on Page 23.**
6. Install glass and center in opening. Use **CW368** temporary glass retainers to hold glass in place until pressure bars are installed. **See DETAIL GG on Page 23.**

NOT TO SCALE

Glazing Structural Silicone Application

- Structural silicone is applied from the interior. Follow silicone manufacturer's instructions and recommendations for surface preparation and silicone application. Mask glass and aluminum and tool sealant.
- After structural silicone has fully cured remove temporary glass retainers from intermediate verticals; insert open cell polyurethane rod between glass edges; mask glass adjacent to joint, and apply outside weatherseal.

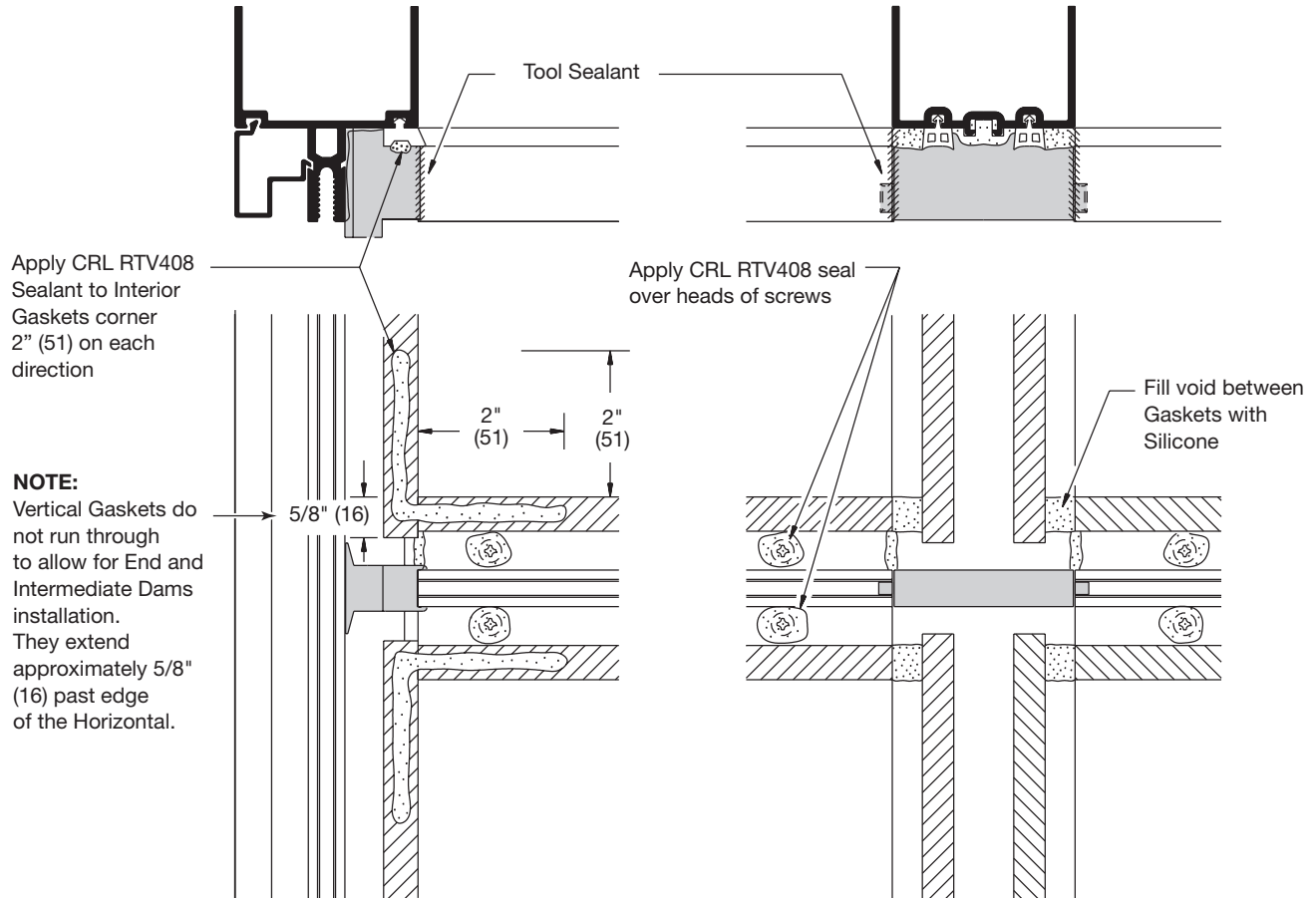

DETAIL FF

CW368 Temporary Glass Retainer.
Torque to 30 in. Pound (3.4 N.m)
NOTE: Do Not Over Torque Glass Retainers Bolts.
Use one Retainer per each 150 lbs. (667.2 N) of load.
(I.E. if glass height x glass width x windload = 350 lbs. use three retainers)

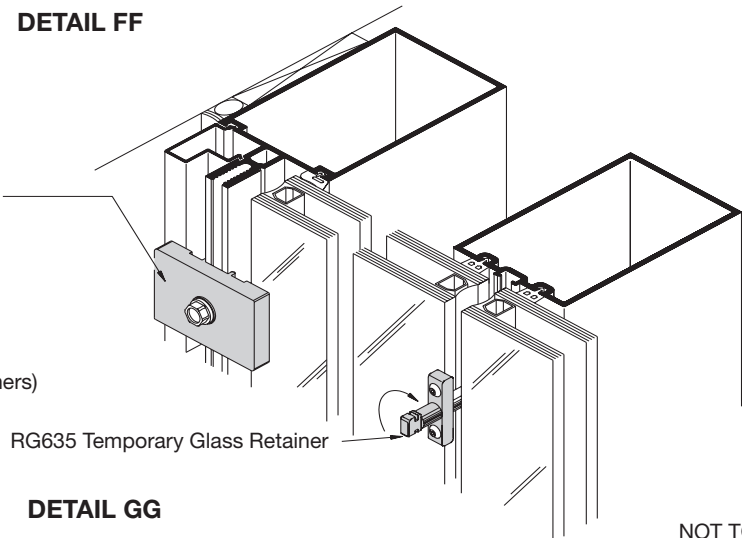

DETAIL GG

NOT TO SCALE

PRESSURE BAR INSTALLATION

Apply CRL RTV408 sealant to faces of end dams prior to installing pressure bars. Pressure bars should be installed while sealant is wet.

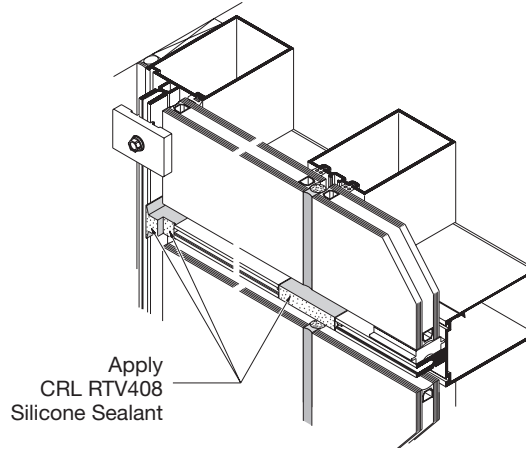

Install vertical pressure bar bolts from bottom to top and horizontal pressure bar bolts from center outward. Always locate bolts 1-1/2" (38) maximum from vertical/horizontal intersections to ensure proper pressure over end dams. **See DETAIL HH. Be sure pressure bar spacer is not disengaged.**

1. Install vertical pressure bars first leaving 1/8" (3) gaps at top and bottom. Using a torque wrench, torque bolts to 30 inch pound (3.4 N.m). Increase torque to 50 to 60 inch pound (5.7 to 6.8 N.m) minimum after all four sides have been secured.
2. Center horizontal pressure bars in opening, leaving 1/8" (3) gaps at each end.

NOTE: Weep slots must be on top side of all horizontal pressure bars and level with bottom of glazing pocket to ensure proper drainage. **See DETAIL HH.**

3. Seal gaps at vertical/horizontal intersections and at top and bottom of vertical pressure bars. **See DETAIL HH.**

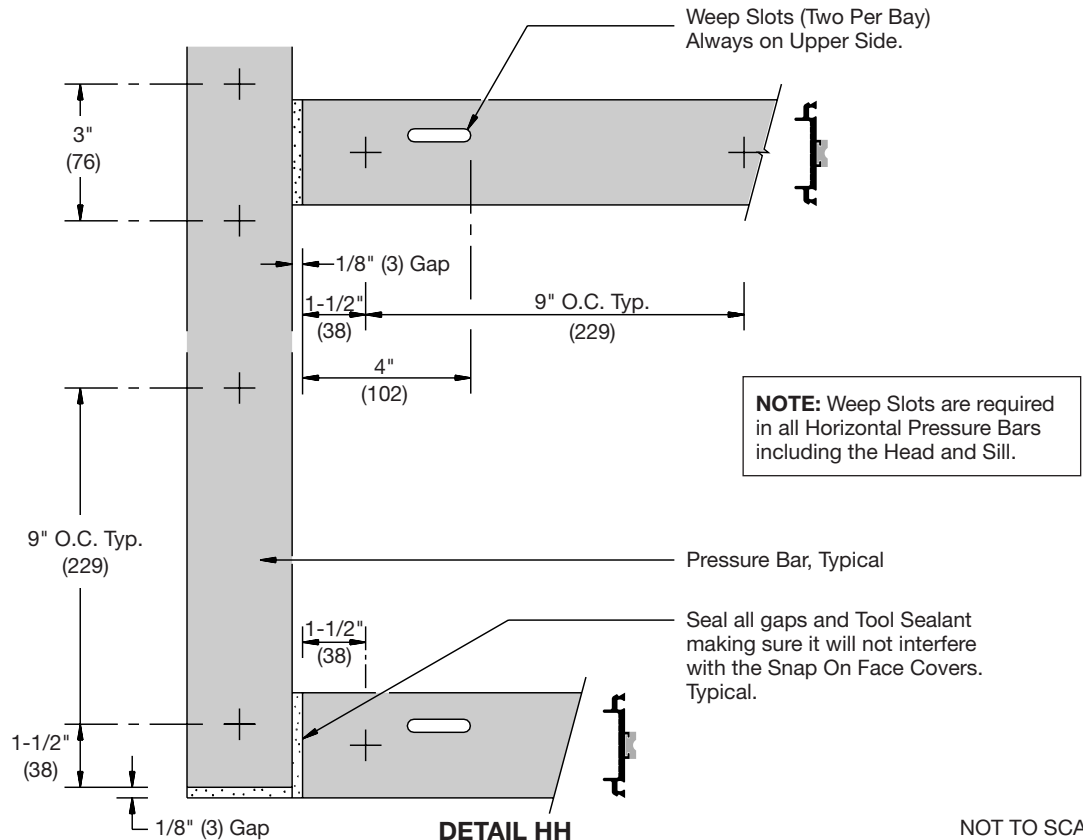

NOT TO SCALE

FACE COVER INSTALLATION

Care must be taken to prevent damage of face covers during installation. Use a piece of wood such as 2" x 4" x 12" (51 x 102 x 305) and Cat. No. ST57550 Compo-Cast dead blow soft face hammer.

1. Install vertical face covers first. Do not disturb top and bottom closure plates when installing face covers. Pinning of vertical face cover is required to prevent slippage. Use one pin on each side per cut length, concealed behind horizontal face cover closer to center line or as shown on shop drawings. **See DETAIL II.**
2. Install snap-in horizontal face covers with the weep holes located on the bottom side.

NOTE: Extended face covers require a special pressure bar. Pin vertical extended covers with one 1/8" (3) Dia. pop rivet on each side per cut length (optional #10 x 1/2" FHSMS) **See DETAIL JJ.** Extended horizontal covers must be pinned on top side at both ends.

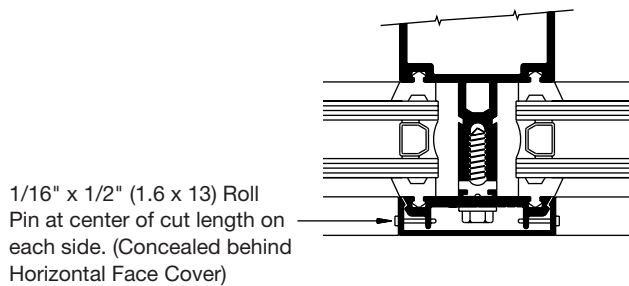

DETAIL II

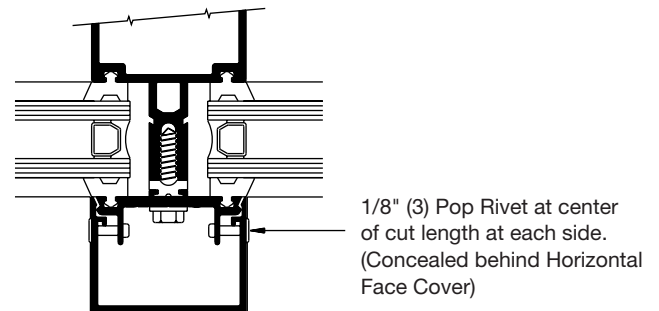

DETAIL JJ

NOTE: Locate splice joints at center line of vertical members. Splice joint width should be based on linear expansion for aluminum specifications and sealant movement capability. Do not align face cover splices with pressure bar splices. Offset by 6" (152) minimum. Set backer rod between face cover and pressure bars at joint and seal.

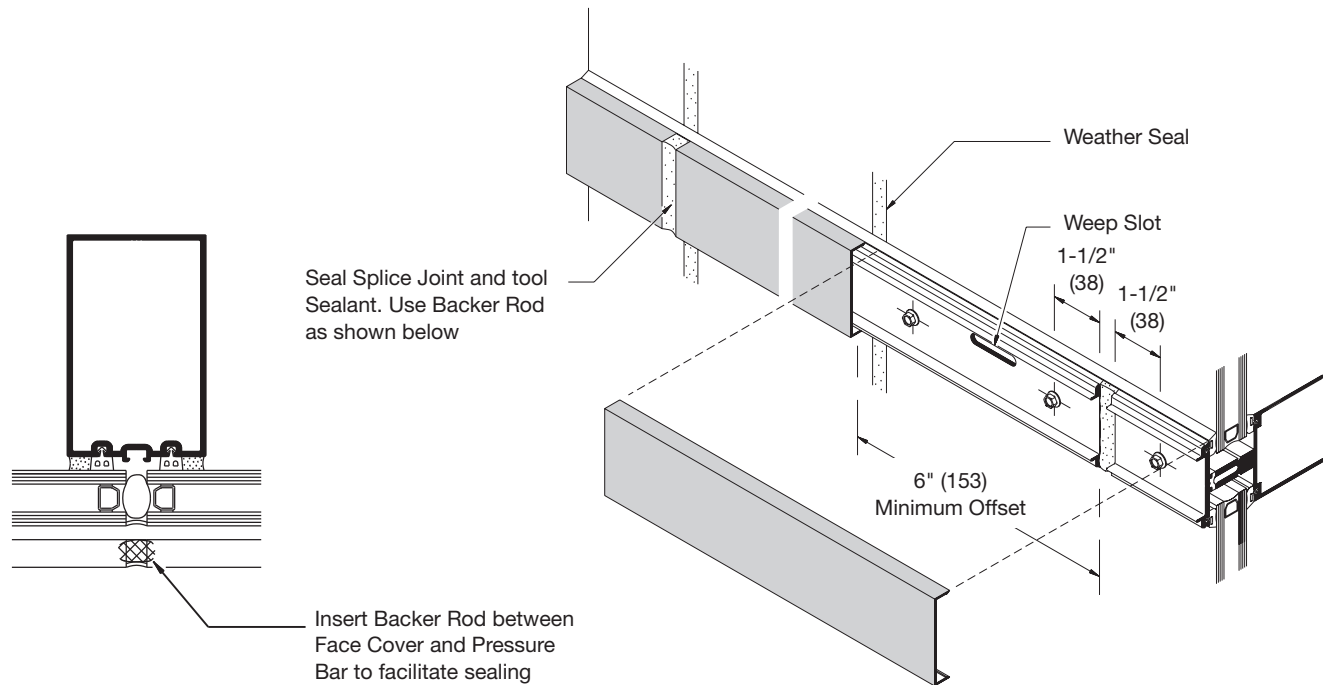

DETAIL KK

NOT TO SCALE

TRANSITION GLAZING

1. Apply CRL RTV408 sealant into gasket reglets before installing snap-in transition adapters.
2. Install vertical adapters first.
3. Install horizontal adapters and seal horizontal/vertical joints. Tool sealant. **See DETAIL LL**

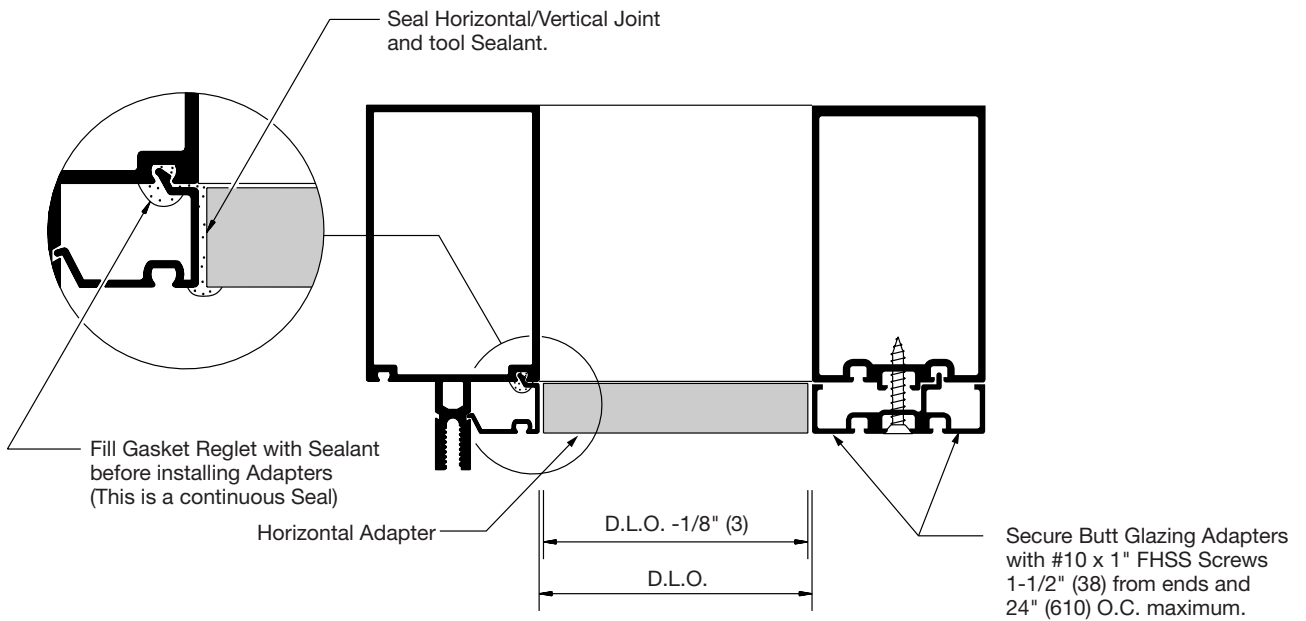
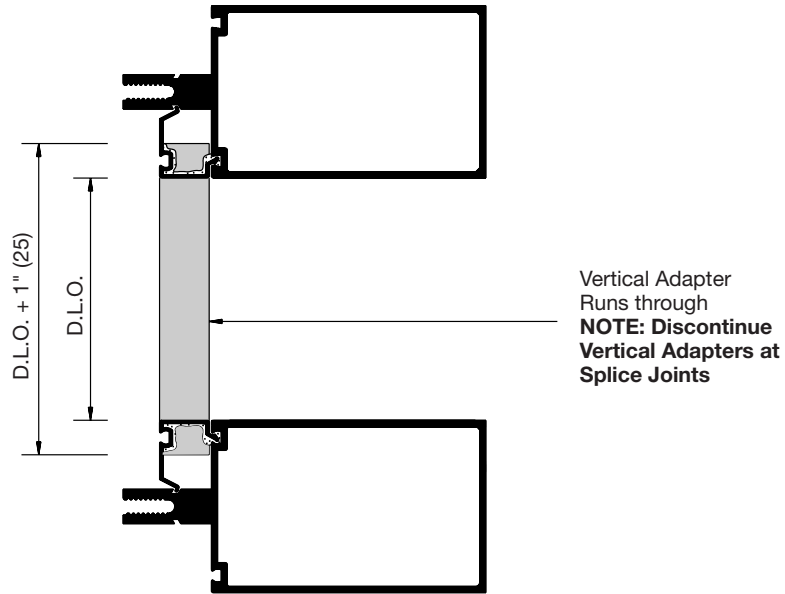

DETAIL LL

NOT TO SCALE

VERTICAL SPLICE JOINTS

Splice joint width should be based on sealant movement capability and on the following formula:

Linear expansion for aluminum, in inches	=	Length (") x F° difference in temperature x .0000129
Linear expansion for aluminum, in millimeters	=	Length (mm) x C° difference in temperature x .0232

A 1/2" (13) minimum joint is recommended. Use a 1/2" (13) spacer shim to set and hold the mullion joint constant during erection. Remove the shim after attaching the verticals to the anchors. **Splice joints must occur at spandrel areas.**

NOTE: Splice joints are designed to accommodate thermal movement only. They do not compensate for variations in floor levels.

1. Clean splice sleeves and all joint surfaces. Apply bond breaker tape to areas where sleeve will be sealed to avoid three side adhesion. **See DETAIL MM.**
2. Slide sleeve into the upper member before it is installed and tape to hold it in retracted position. **See DETAIL LL.**

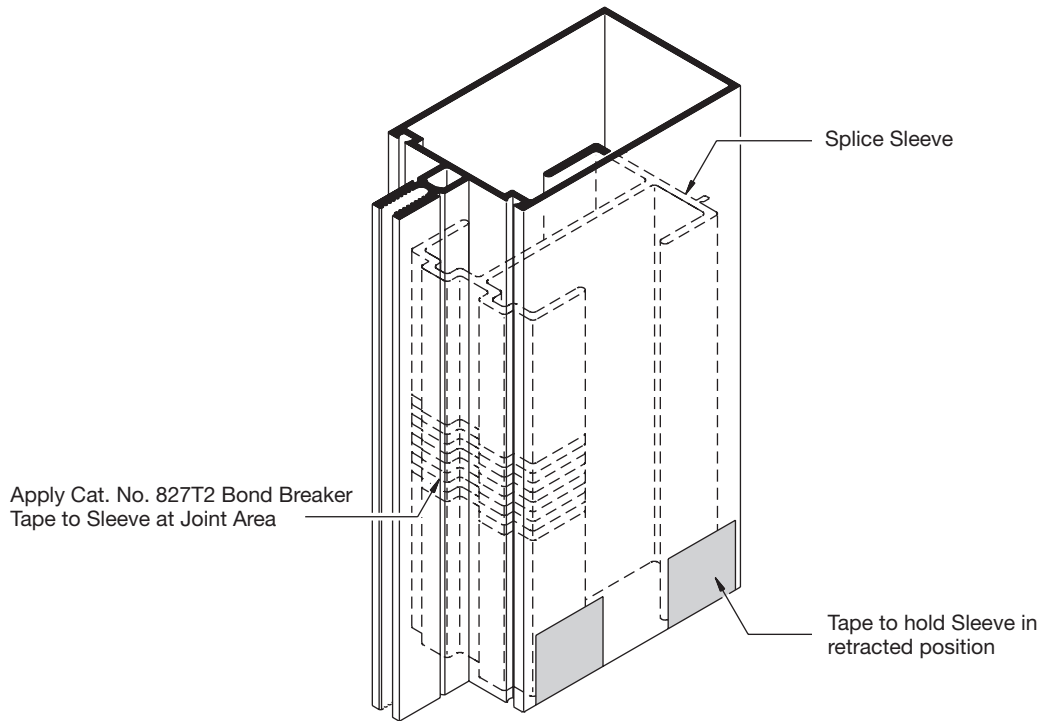

DETAIL MM

3. Install stop screw, 2-3/4" (70) down from top of extrusion at inside of lower member. **See DETAIL OO on Page 28.**
4. Install upper member and let extruded sleeve slide down until it sits on top of stop screw.
5. Seal joint over sleeve as shown in **DETAIL NN on Page 28.** When transition adapters for 1/4" (6) spandrel are used they should be discontinued at splice joint and installed after splice joint is sealed. Stagger joints on back members, pressure bars and face caps as shown in **DETAIL OO on Page 28.**
6. Seal pressure bar joint. **See DETAIL OO on Page 28.**
7. Install face covers and seal joint using backer rod as required. **See DETAIL OO on Page 28.**

NOT TO SCALE

SERIES 2100/2200 CURTAIN WALL

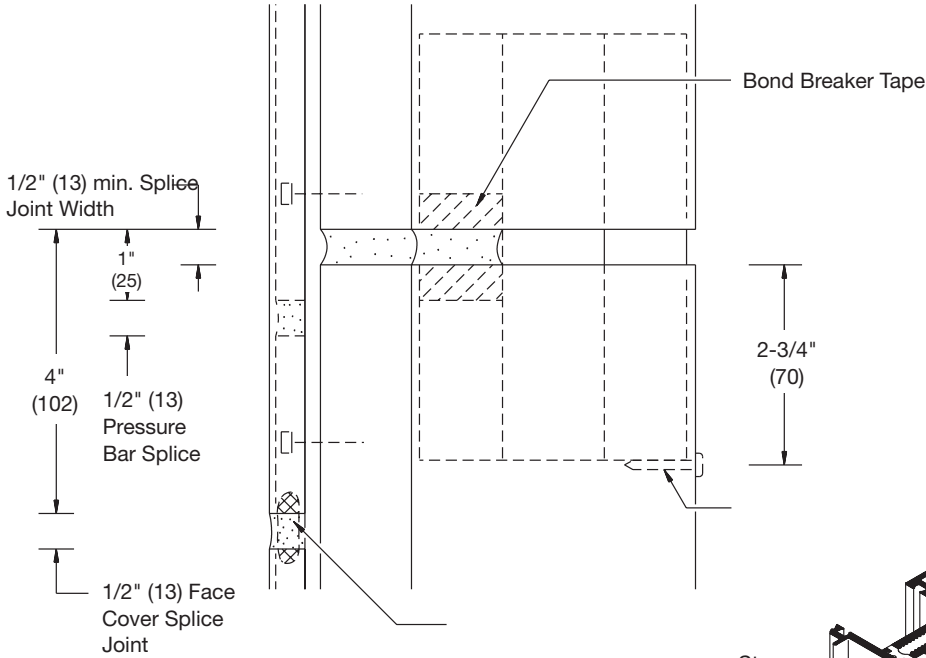
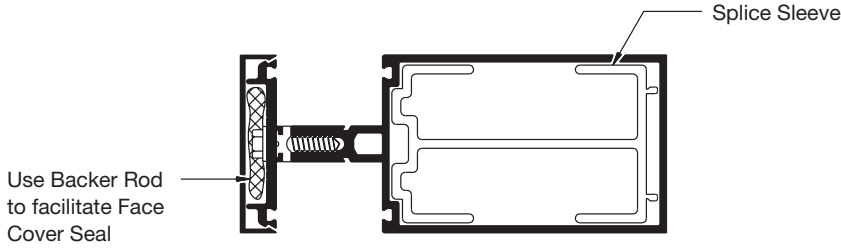

DETAIL PP

NOTE: Seal Face Cover Joint and tool (Use Backer Rods as required)

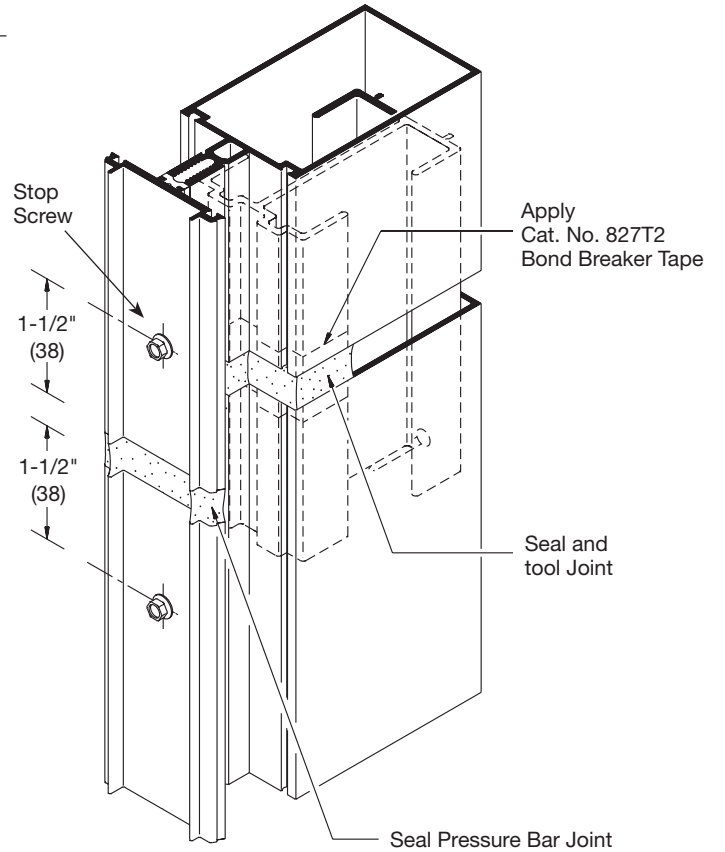

DETAIL OO

NOT TO SCALE

MULTI-SPAN CONDITION

DETAIL PP and QQ show fixed (deadload) and expansion (windload) anchors. Anchor type and size vary per job requirements. Details shown are to be used as a guide only. See approved shop drawings for actual conditions.

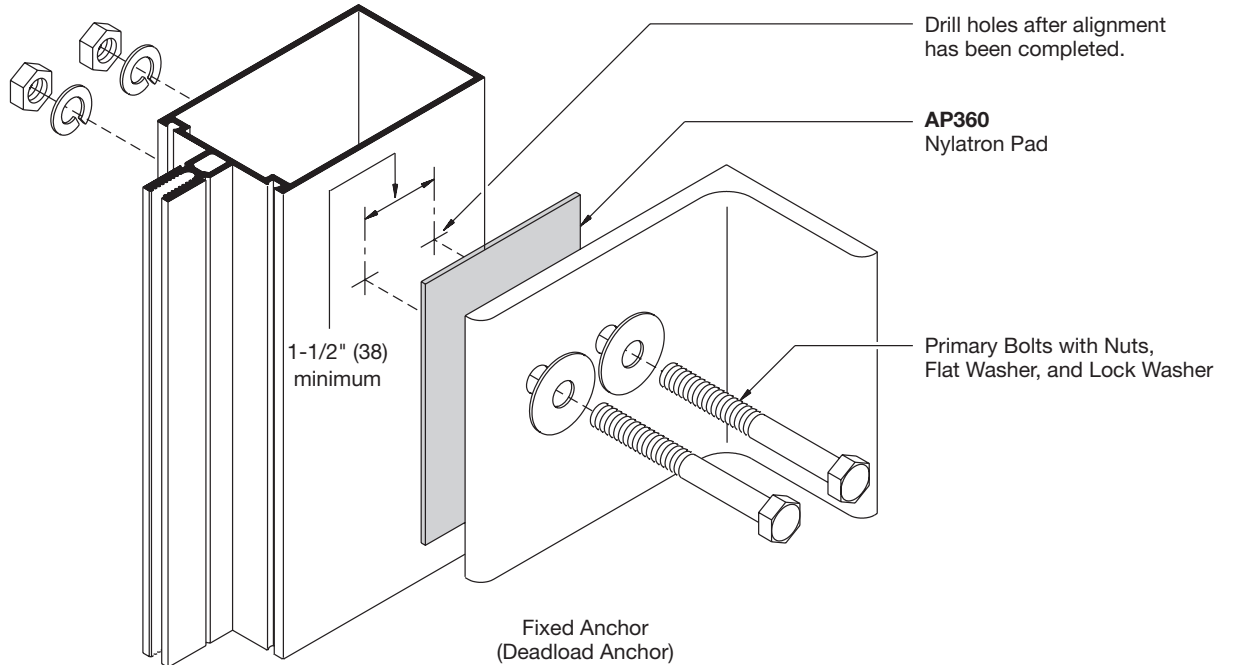

DETAIL PP

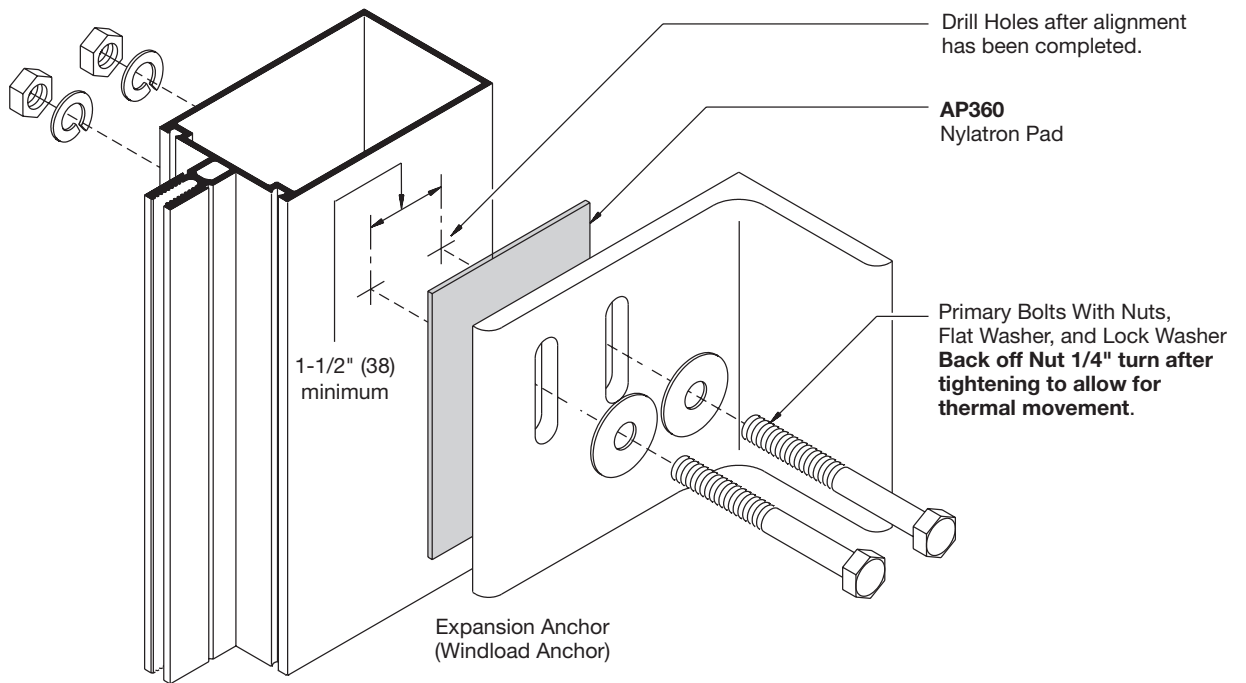

DETAIL QQ

Secure verticals to anchor clips after alignment has been completed.

NOTE: Mullion spacing must be held to within +1/32" (0.8). Check overall frame dimension every four bays to monitor dimension build up.

NOT TO SCALE

ENTRANCE FRAMES

Refer to Entrances, for Entrance Frame fabrication and installation.

Entrance Frames may be installed simultaneously with Curtain Wall or after Curtain Wall installation has been completed.

Use **CW917** or **CW916** pocket fillers to close glazing pocket at door side.

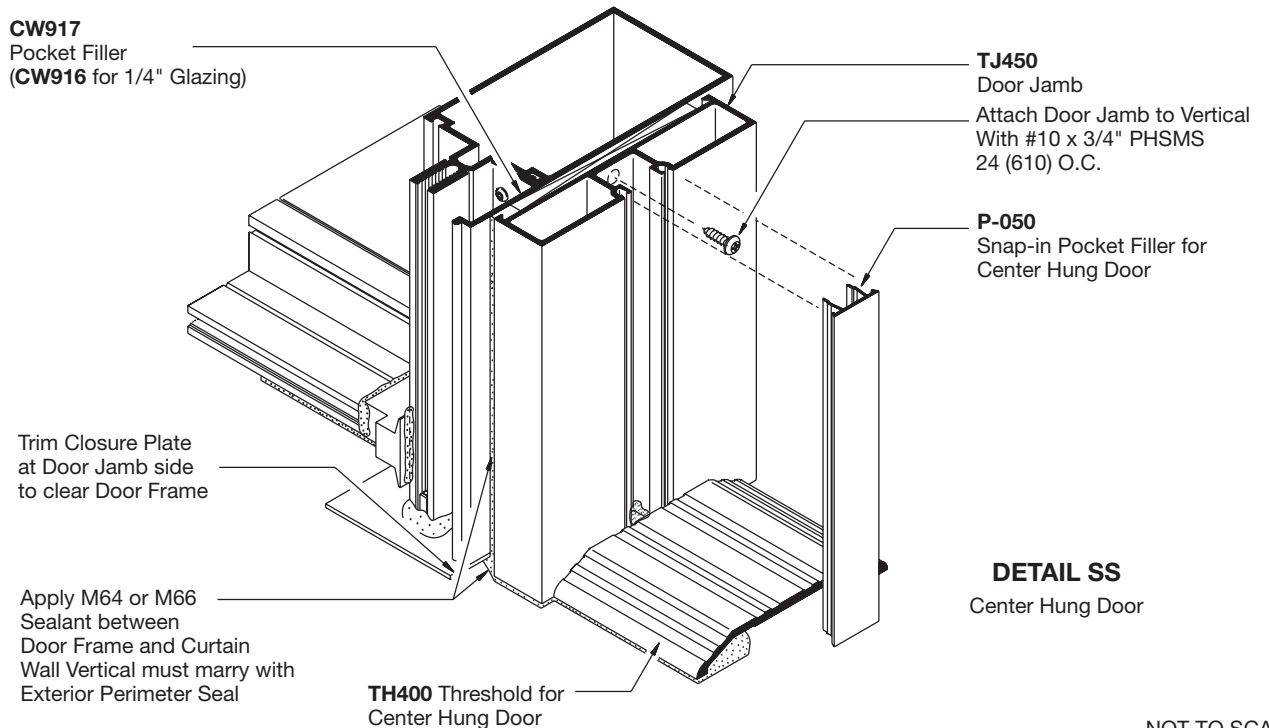
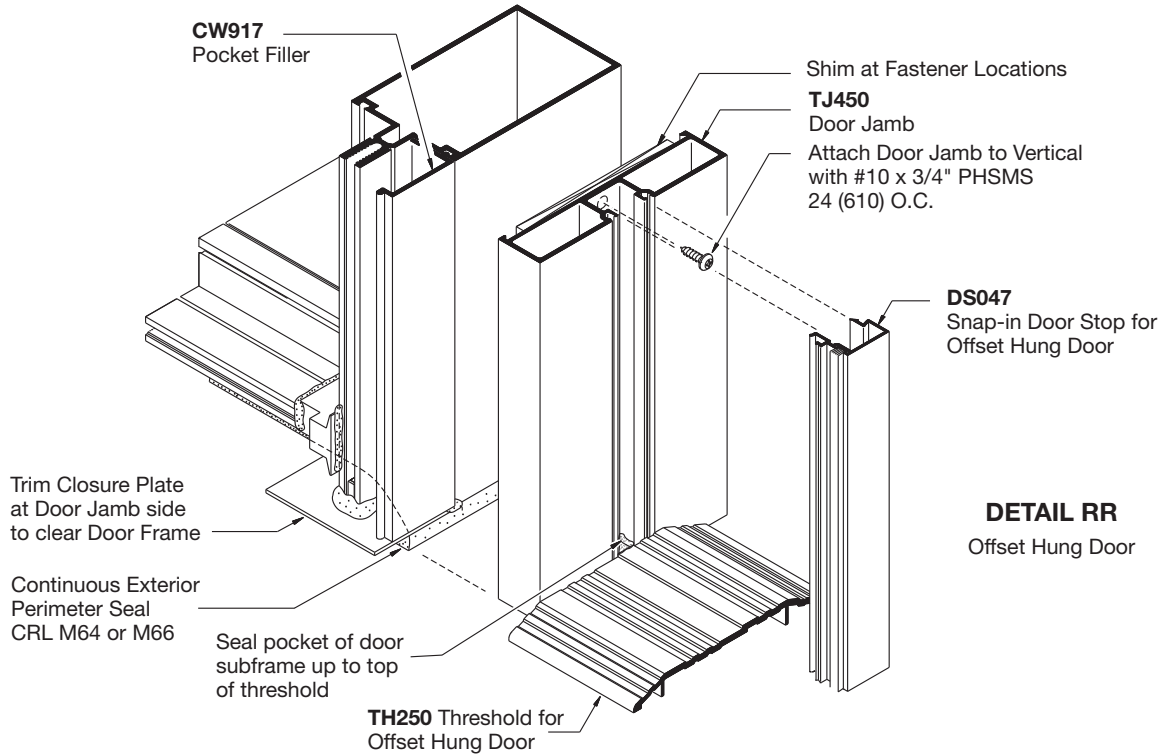

NOT TO SCALE

FLUSH DOOR ADAPTOR FABRICATION AND INSTALLATION

Fabrication

NOTE: Flush door adaptors are not available for Series 2100 butt glaze applications

1. Cut door adaptor members to length.

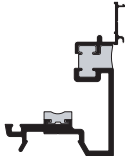

CW207

Header Adaptor Length = DOOR OPENING WIDTH MINUS 1/32" (0.8).

Jamb Adaptor Length = DOOR OPENING HEIGHT Plus 7/16" (11).



CW206

Header Cap Length = DOOR OPENING WIDTH MINUS 1/32" (0.8).

Jamb Cap Length = DOOR OPENING HEIGHT Plus 7/16" (11).

(Field cutting may be required to obtain a tight joint with vertical cap above)



CW209

Header DoorStop Length = DOOR OPENING WIDTH MINUS 1/32" (0.8).

Jamb DoorStop Length = DOOR OPENING HEIGHT MINUS 1-1/32" (29).

2. Drill 5/16" (8) diameter anchor holes in all cut to length adaptors 1-1/2" (38) from each end and 9" (229) O.C. See **DETAIL A**.

NOTE: Isolator must be in place prior to drilling anchor holes.

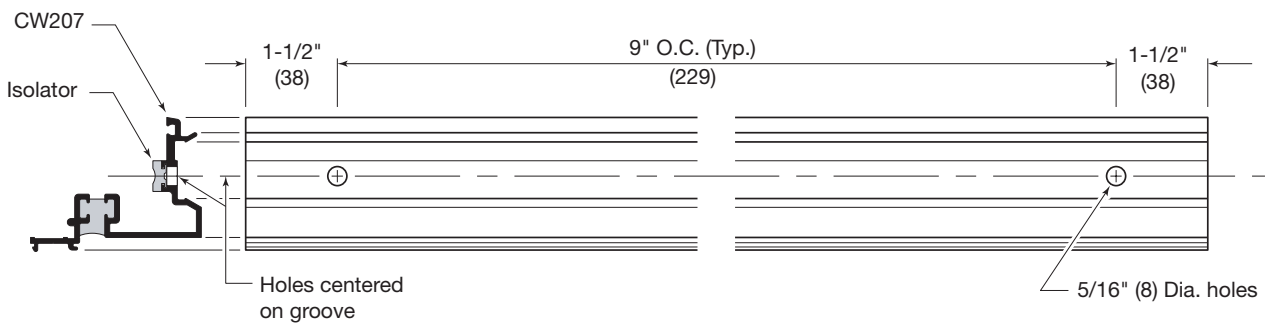

DETAIL TT

NOT TO SCALE

FLUSH DOOR ADAPTOR FABRICATION AND INSTALLATION

Fabrication

- For butt hung doors, fabricate header adaptor for weep slots and additional anchor holes as **shown in DETAIL UU**. (Refer to the *Entrances and Frames* section of this manual for flush bolt and panic rod strike fabrication.)

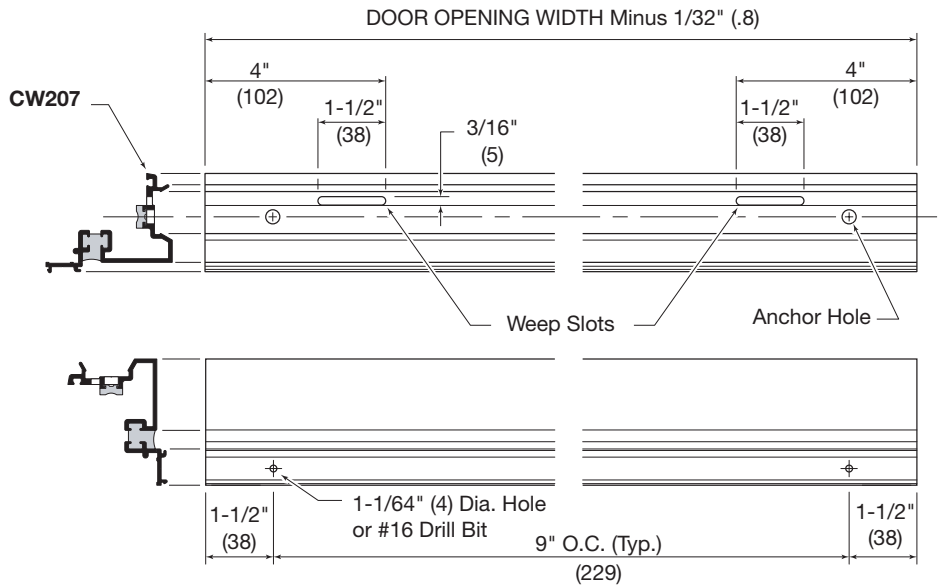

DETAIL UU

- For offset pivot doors, fabricate header adaptor for pivot (Left hand shown), weep slots and additional anchor holes as **shown in DETAIL VV**. Notch face cap for pivot clearance as **shown in DETAIL WW**. (Refer to the *Entrances and Frames* section of this manual for flush bolt and panic rod strike fabrication.)

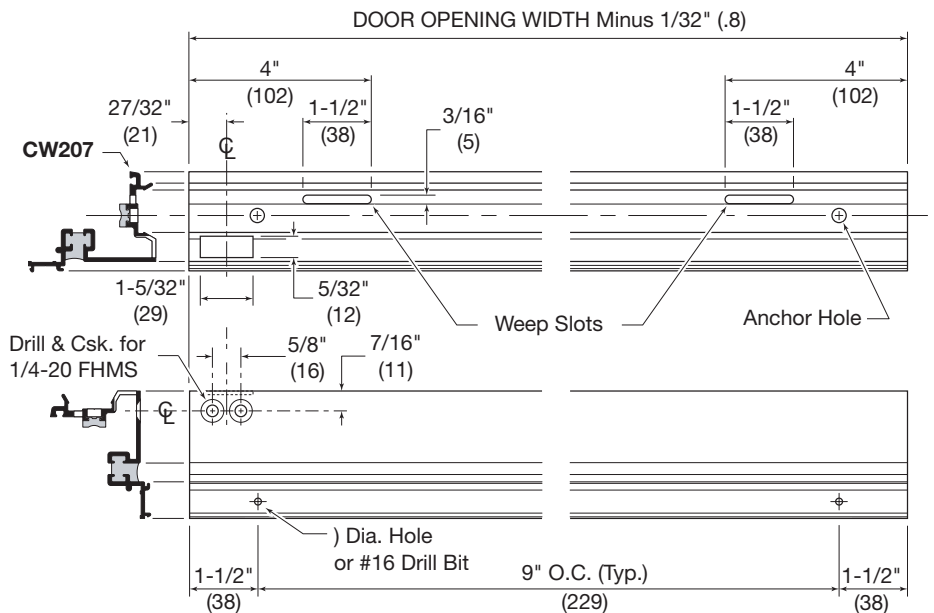

DETAIL VV

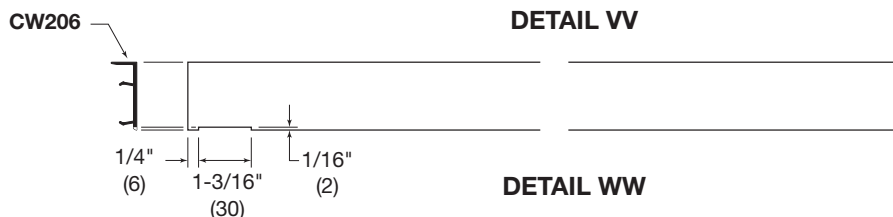

DETAIL WW

NOT TO SCALE

FLUSH DOOR ADAPTOR FABRICATION AND INSTALLATION

5. Fabricate for lock jamb **see DETAIL XX.**
(Right hand shown; left hand opposite)

6. Fabricate for butt hinges **see DETAIL YY.**
(Left hand shown; right hand opposite)

Fabrication

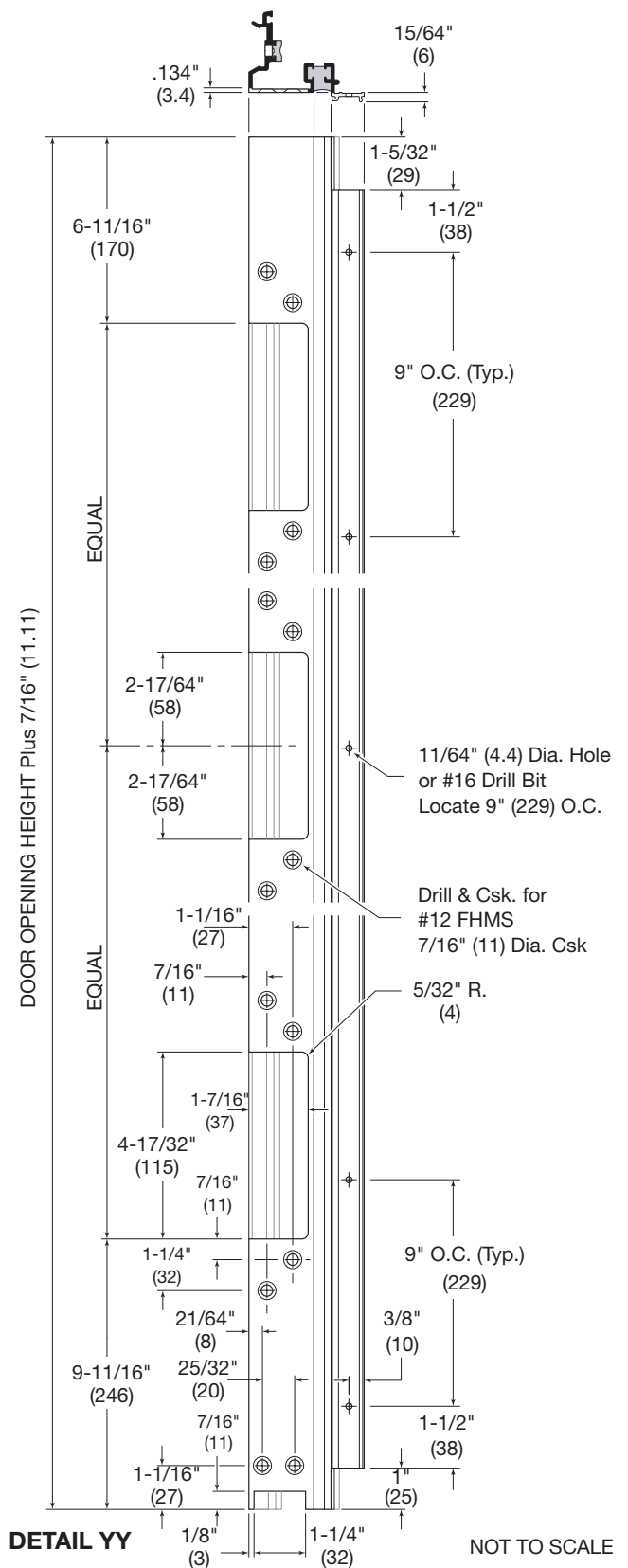
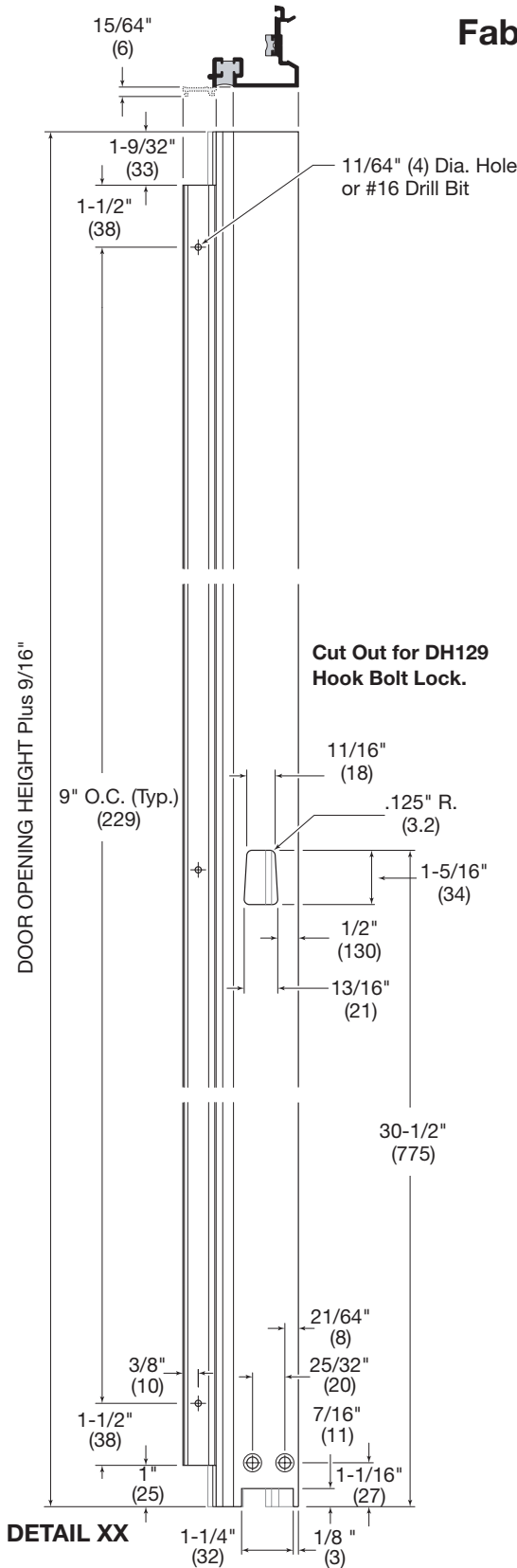

FLUSH DOOR ADAPTOR FABRICATION AND INSTALLATION

Fabrication

7. Fabricate for offset pivots see **DETAIL ZZ**. (Left hand shown; right hand opposite)

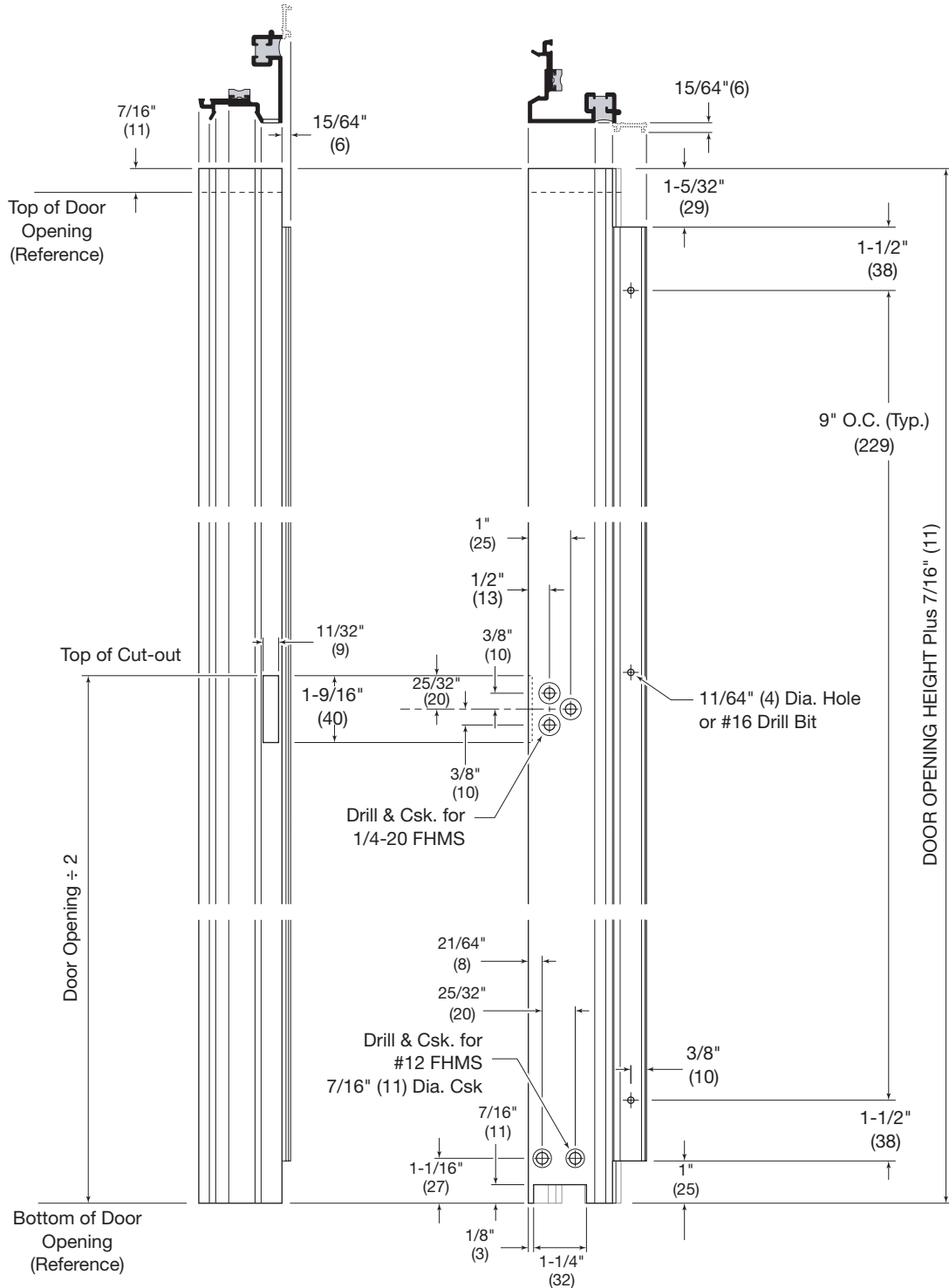

DETAIL ZZ

NOT TO SCALE

FLUSH DOOR ADAPTOR FABRICATION AND INSTALLATION

Fabrication

- For butt hung application, install hinge back up plates and threshold clips as **shown in DETAIL A** and **DETAIL B**. For offset pivot application, install bottom frame portion pivot(s) as **shown in DETAIL J**. Single doors require threshold clip at lock jamb. **See DETAIL C**.
- Install gaskets in door adaptors.

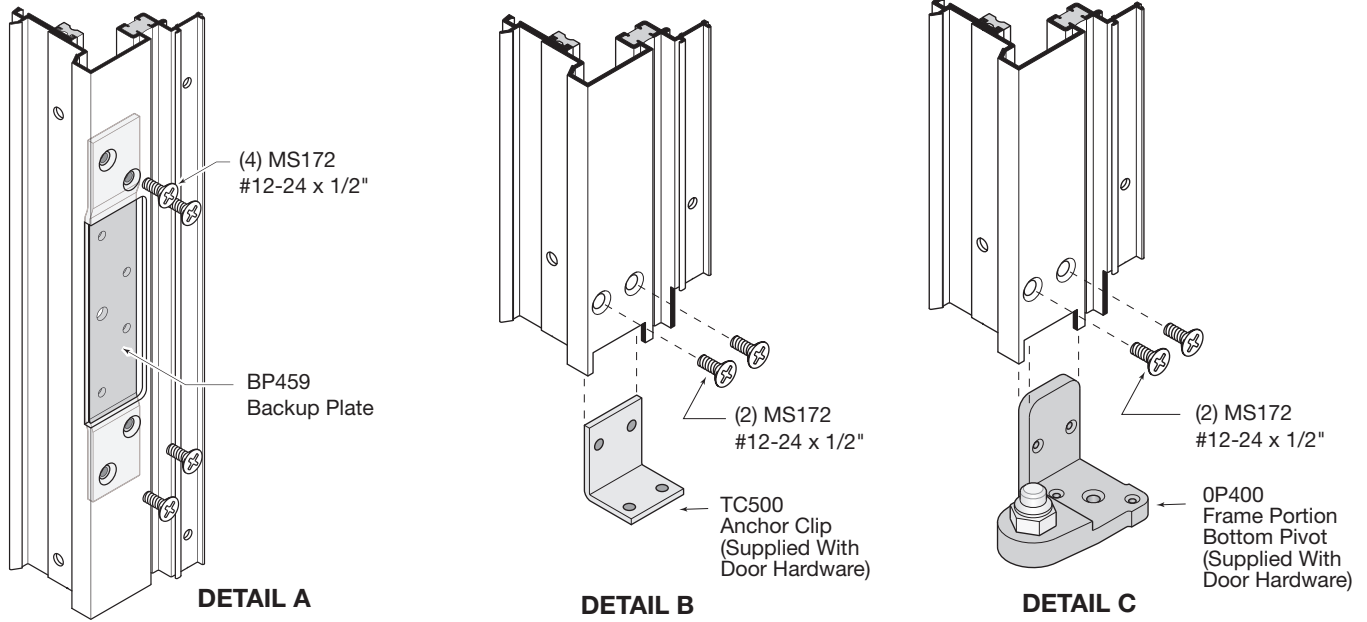

These hardware items must be applied prior to door adaptor installation.

Installation

NOTE: Prior to adaptor installation all end dams must be installed and sealed. Transom and sidelight glass must be in place.

- Seal face of end dams as **shown in DETAIL D**.
- Install jamb and head adaptors using MS222 pressure bar bolts as **shown in DETAIL K**. Refer to page 24 of the glazing portion of this section for bolt tightening procedures. Vertical adaptors extend from floor to 7/16" above bottom of door header/horizontal and must be installed prior to head adaptor installation.
- Secure adaptors to mullion side walls with ST194 tek screws as **shown in DETAIL K**.

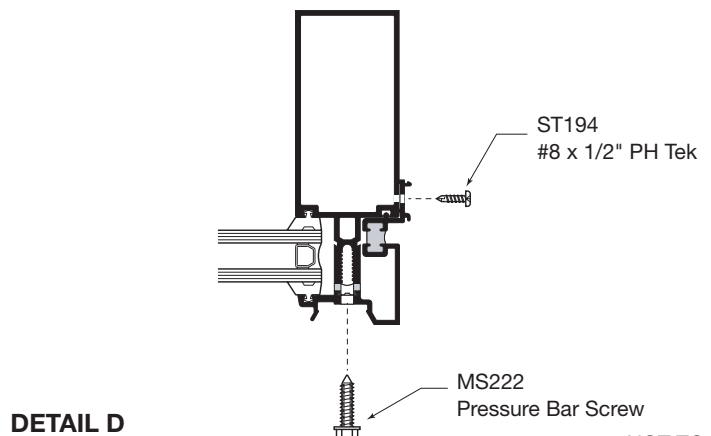
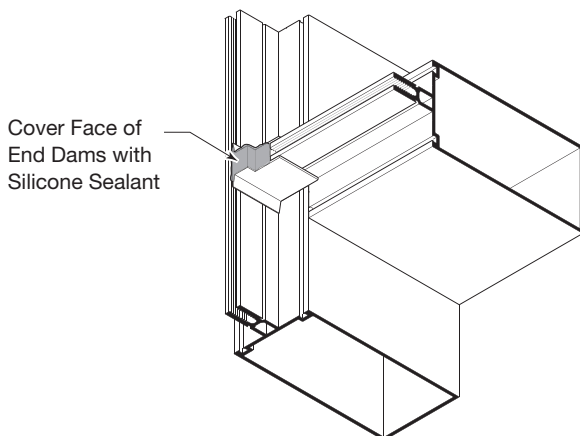

NOT TO SCALE

FLUSH DOOR ADAPTOR FABRICATION AND INSTALLATION

Installation

4. Seal all pressure bar bolt heads. **See DETAIL E.**
5. Seal gaps at intersections of pressure bars and door adaptors.
NOTE: THIS IS A CRITICAL SEAL.

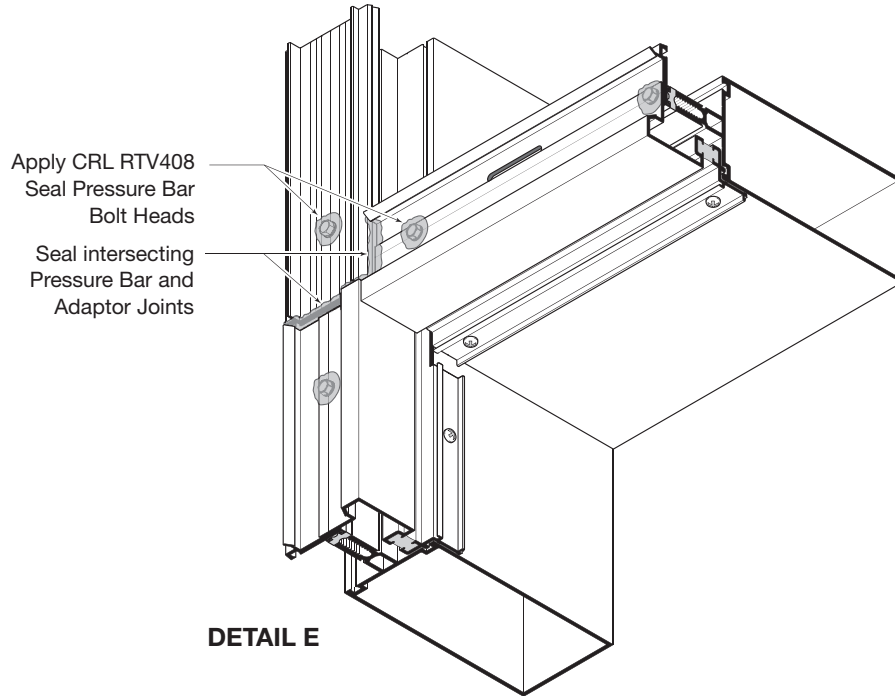

6. Install thresholds into opening using screws provided with door hardware.
See DETAIL F for butt hung, DETAIL G for offset pivot application.

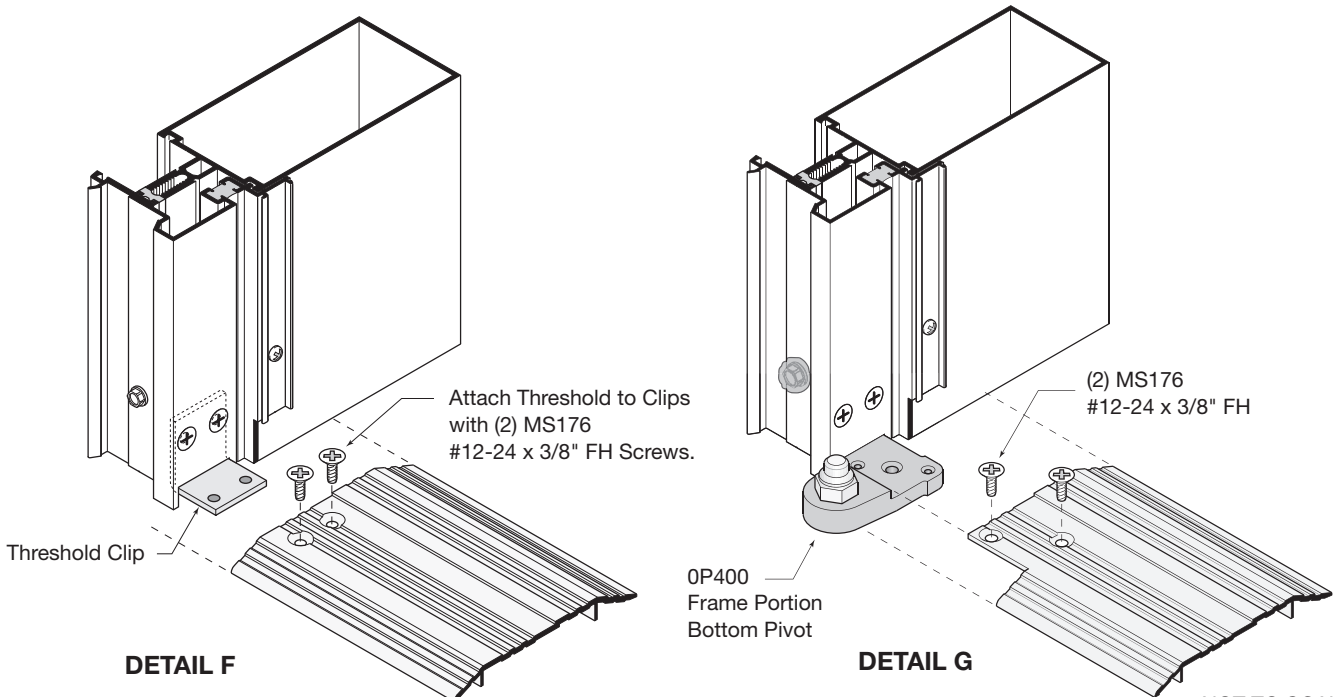

FLUSH DOOR ADAPTOR FABRICATION AND INSTALLATION

Installation

7. Snap on face caps. **See DETAIL H.** Vertical face caps run from floor to 9/16" (14) above bottom of header.
(Field cutting to length is recommended)
8. Snap door stop on header adaptor. **See DETAIL H.** (Head door stop runs through)
9. Snap door stops on jamb members. **See DETAIL H.**

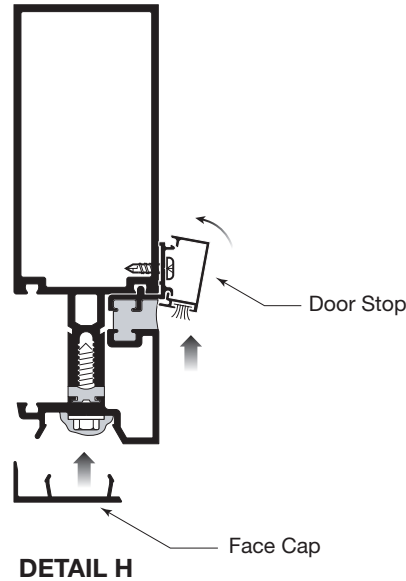

10. For offset pivot doors, install frame portion pivots **as shown.** **See DETAIL I.**

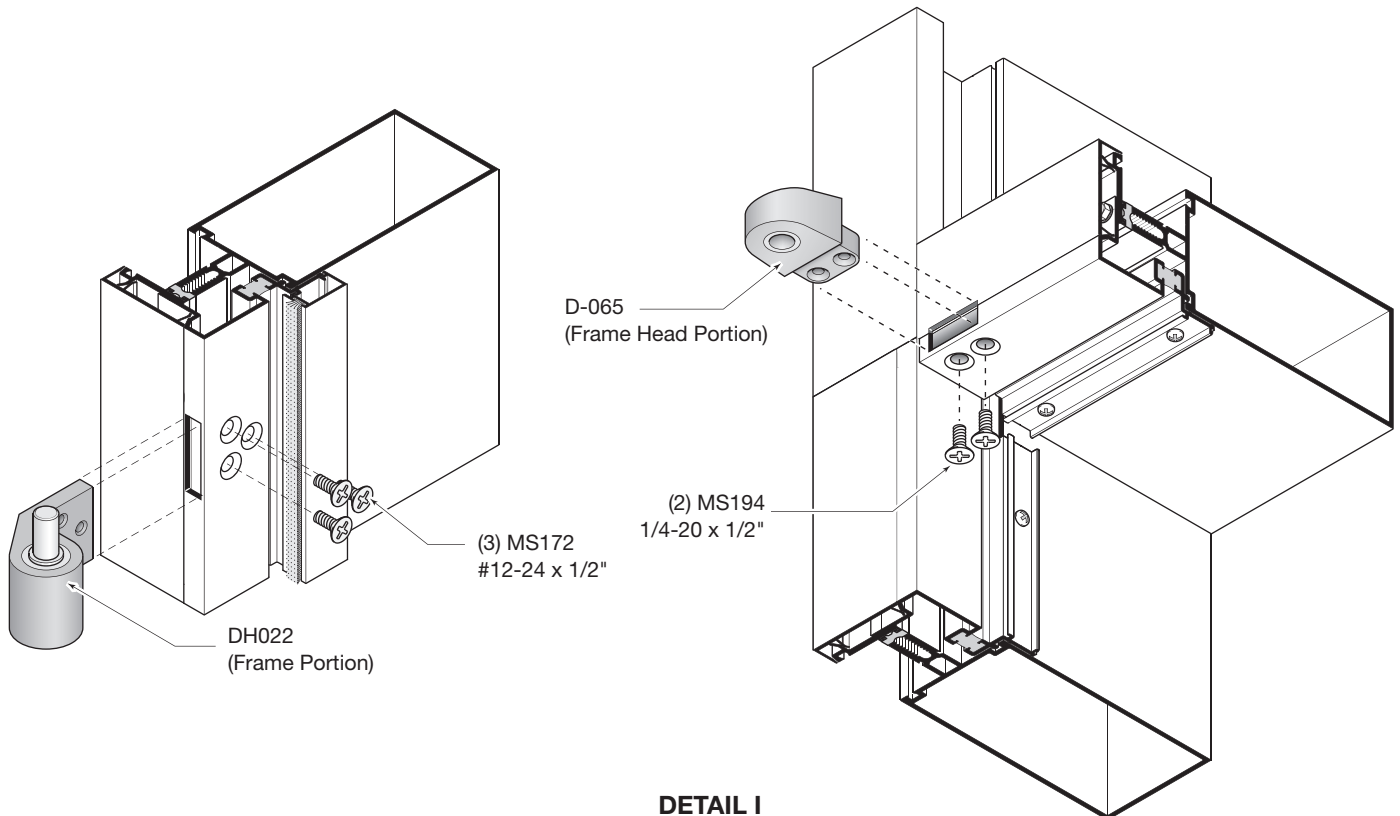

NOT TO SCALE



GUIDE TO SEALANTS

NOTE: All sealants must be tooled to ensure proper adhesion.

WATERPROOFING

- **33S ACETIC CURE SILICONE**

Sill to Subsill, End Dams, Screw Heads, and Threshold to Door Frame Sealing.

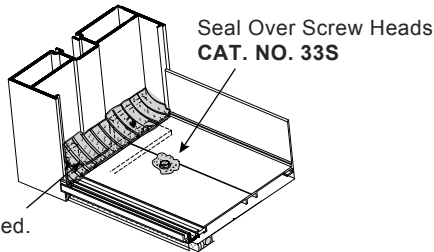

NOTE: Not for use near insulating glass units with butyl sealant.

EXPANSION

- **95C SILICONE BUILDING SEALANT**

Expansion Joints.

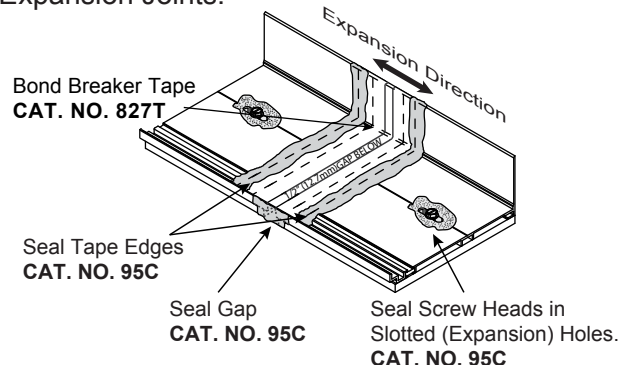

JOINT ADHESIVE

- **RTV408 NEUTRAL CURE SILICONE**

Small Joints, End Joints and Buttered Surfaces, Water Diverters, End Dams, and Reglet Fills.

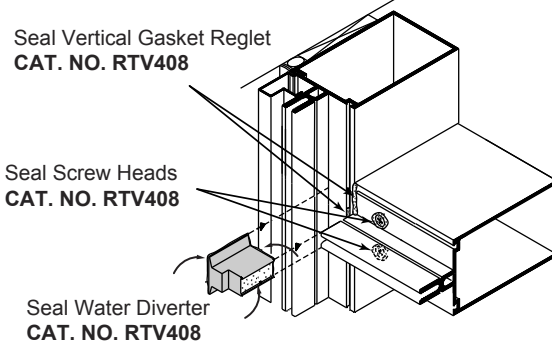
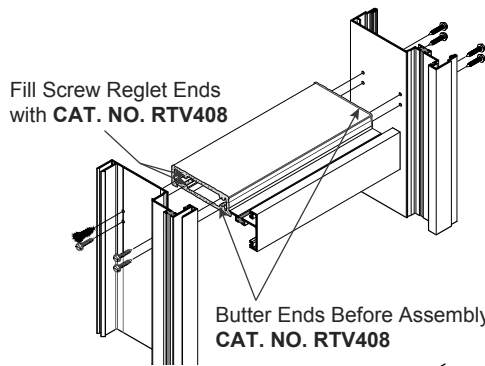

NOTE: I.G. butyl contact OK.

PERIMETER

- **95C SILICONE BUILDING SEALANT (Preferred)**
- **M64 (SMOOTH) MODIFIED POLYURETHANE**
- **M66 (TEXTURED) MODIFIED POLYURETHANE**

Perimeter Seals, Expansion Joints, Sill and Threshold Beds, Concrete, Wood, and Steel Openings.

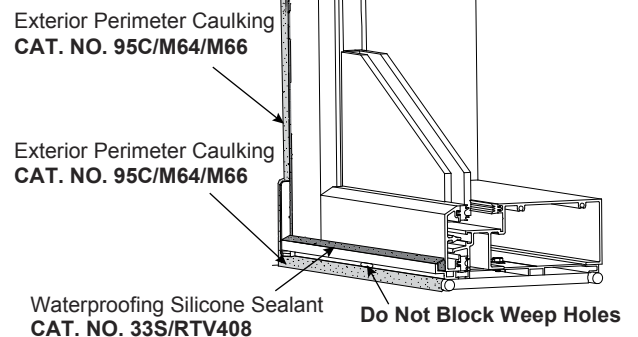

STRUCTURAL

- **ALL STRUCTURAL SEALANTS REQUIRE TESTING AND APPROVAL.**

Glass-to-Glass or Glass-to-Metal

This concludes the instructional documentation for the SERIES 2100/2200. For additional product information visit our website a www.crlaurence.com or call 1-323-588-1281 and ask for the Technical Sales Department.