

# INSTALLATION INSTRUCTIONS

## SERIES 3150 CURTAIN WALL

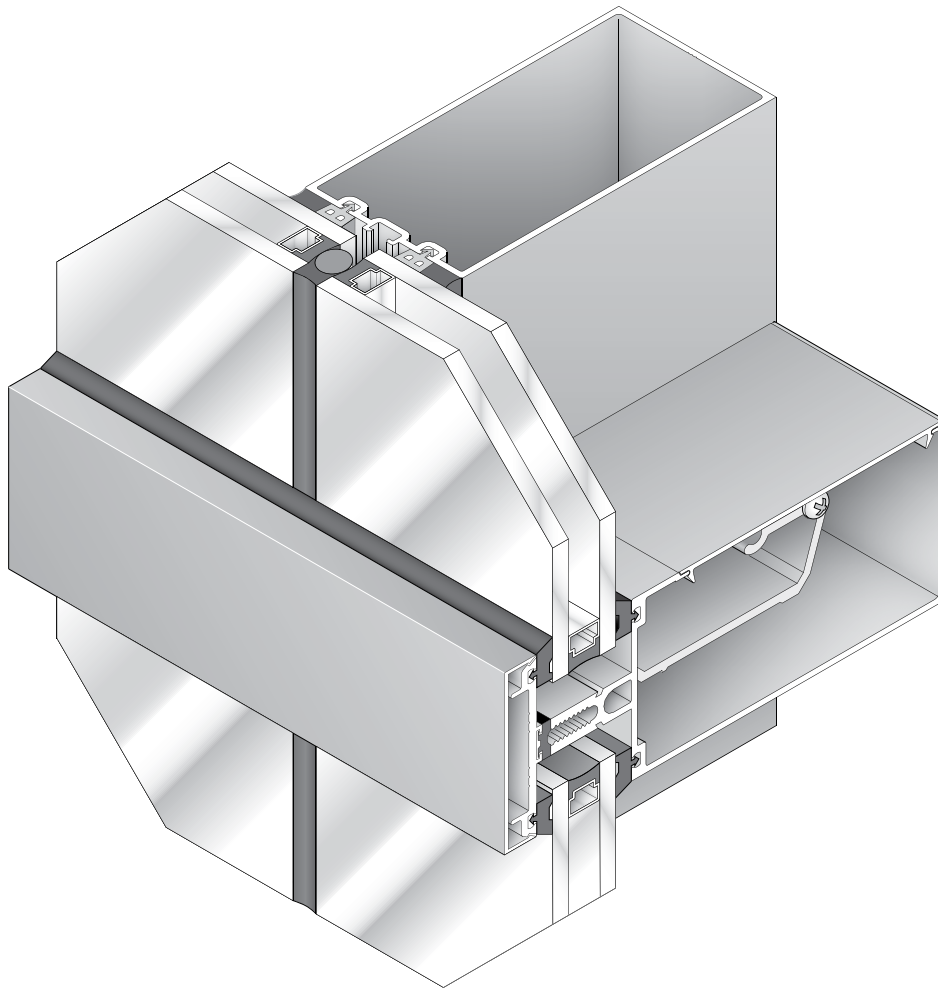

---

Phone: (800) 262-5151 • Fax: (866) 262-3299  
crlaurence.com • usalum.com • crl-arch.com

---

# HANDLING, STORAGE, AND PROTECTION OF ALUMINUM

The following precautions are recommended to protect the material against damage. Following these precautions will help ensure early acceptance of your products and workmanship.

**A. HANDLE CAREFULLY.**

All aluminum materials at job site must be stored in a safe place, well removed from possible damage by other trades. Cardboard wrapped or paper interleaved materials must be kept dry.

**B. CHECK ARRIVING MATERIALS.**

Check for quantities and keep records of where various materials are stored.

**C. KEEP MATERIALS AWAY FROM WATER, MUD, AND SPRAY.**

Prevent cement, plaster, or other materials from damaging the finish.

**D. PROTECT THE MATERIALS AFTER ERECTION.**

Protect erected frame with polyethylene or canvas splatter screen. Cement, plaster, terrazzo, other alkaline solutions, and acid based materials used to clean masonry are harmful to the finish. ***If any of these materials come in contact with the aluminum, immediately remove with water and mild soap.***

**NOTE:** Any modifications, other than those specified in this document, could result in this product's failure to meet UL safety ratings and void the manufacturer's warranties.

The rapidly changing technology within the architectural aluminum products industry demands that C.R. Laurence/U.S. Aluminum reserve the right to revise, discontinue, or change any product line, specification, or electronic media without prior written notice.

**NOTE:** Dimensions in parentheses ( ) are millimeters unless otherwise noted.

# GENERAL INSTALLATION NOTES

## Recommended guidelines for all installations:

- 1. REVIEW CONTRACT DOCUMENTS.** Check shop drawings, installation instructions, architectural drawings, and shipping lists to become thoroughly familiar with the project. The shop drawings take precedence and include specific details for the project. Note any *field verified* notes on the shop drawings prior to installing. The installation instructions are of a general nature and cover most conditions.
- 2. INSTALLATION.** All materials are to be installed plumb, level, square, and true.
- 3. BENCH MARKS.** All work should start from bench marks and/or column lines as established by the architectural drawings and the general contractor with guaranteed accuracy. Working from these datum points and lines determine:
  - a) The plane of the wall in reference to offset lines provided on each floor.
  - b) The finish floor lines in reference to bench marks on the outer building columns.
  - c) Mullion spacing from both ends of masonry opening to prevent dimensional build-up of daylight opening.
- 4. STEEL ANCHORS.** Steel anchors that weld to steel structure are normally line set before mullions are hung. Outstanding leg of anchors must be at 90 degrees to offset lines. Mullion space should be held to  $\pm 1/32"$  (0.8). Anchor clips vary per job conditions. Follow approved shop drawings for size and location of clips.
- 5. FIELD WELDING.** All field welding must be adequately shielded to avoid any splatter on glass or aluminum. Results will be unsightly and/or structurally unsound. Advise general contractor and other trades accordingly. All field welds of steel anchors must receive touch-up paint (zinc chromate) to avoid rust.
- 6. SURROUNDING CONDITIONS.** Make certain that construction which will receive your materials is in accordance with the contract documents. If not, notify the general contractor in writing and resolve differences before proceeding with work.
- 7. ISOLATION OF ALUMINUM.** Aluminum to be placed in direct contact with uncured masonry or incompatible materials should be isolated with a heavy coat of zinc chromate or bituminous paint.
- 8. SEALANTS.** Sealants must be compatible with all materials with which they have contact, including other sealant surfaces. Consult with sealant manufacturer for recommendations relative to joint size, shelf life, compatibility, cleaning, priming, tooling, adhesion, etc. It is the responsibility of the **Glazing Contractor** to submit a statement from the sealant manufacturer indicating that glass and glazing materials have been tested for compatibility and adhesion with glazing sealants, and interpreting test results relative to material performance, including recommendations for primers and substrate preparation required to obtain adhesion. The chemical compatibility of all glazing materials and framing sealants with each other and with like materials used in glass fabrication must be established. ***This is required on every project.***
- 9. FASTENING.** Within the body of these instructions "fastening" means any method of securing one part to another or to adjacent materials. Only those fasteners used within the system are specified in these instructions. Due to the varying perimeter conditions and performance requirements, perimeter and anchor fasteners are not specified in these instructions. For perimeter and anchor fasteners refer to the shop drawings or consult the fastener supplier.
- 10. BUILDING CODES.** Due to the diversity in state/provincial, local, and federal laws and codes that govern the design and application of architectural products, it is the responsibility of the individual architect, owner, and installer to assure that products selected for use on projects comply with all the applicable building codes and laws. U.S. Aluminum exercises no control over the use or application of its products, glazing materials, and operating hardware, and assumes no responsibility thereof.
- 11. EXPANSION JOINTS.** Expansion joints and perimeter seals shown in these instructions and in the shop drawings are shown at normal size. Actual dimensions may vary due to perimeter conditions and/or difference in metal temperature between the time of fabrication and the time of installation. Gaps between expansion members should be based on temperature at time of installation.
- 12. WATER HOSE TEST.** As soon a representative amount of the wall has been glazed (500 square feet or 46.5m<sup>2</sup>) a water hose test should be conducted in accordance with AAMA 501.2 specifications to check the installation. On all jobs the hose test should be repeated every 500 square feet (46.5m<sup>2</sup>) during the glazing operation.
- 13. COORDINATION WITH OTHER TRADES.** Coordinate with the general contractor any sequence with other trades which offset curtain wall installation (i.e. fire proofing, back-up walls, partitions, ceilings, mechanical ducts, converters, etc.).
- 14. CARE AND MAINTENANCE.** Final cleaning of exposed aluminum surfaces should be done in accordance with AAMA 609.1 for anodized aluminum and 610.1 for painted aluminum.

# STRUCTURAL SILICONE GLAZING

1. **SEALANTS.** All sealants referenced in these instructions must be a one part elastomeric silicone and must be applied according to the silicone manufacturer's recommendations.
2. **APPLICATION.** Structural silicone must be applied from the interior and weatherseal from the exterior after the interior structural silicone has fully cured.
3. **MAXIMUM ALLOWABLE STRESS ON SILICONE.** The maximum allowable size of the glass lite is controlled by the width and depth of the silicone joint combined with the specified design windload (PSF or Pa). The stress on the structural silicone must not exceed 20 PSI (137 KPa) for a 6:1 safety factor. Check Structural Silicone Chart in the Architectural Design Manual for this product series.
4. **ARCHITECT.** It is the responsibility of the architect to secure approval of the system and request from the Glazing Contractor the compatibility and adhesion test reports described below.
5. **GLAZING CONTRACTOR.** It is the responsibility of the Glazing Contractor to submit a statement from the sealant manufacturer indicating that glass and glazing materials have been tested for compatibility and adhesion with glazing sealants and interpreting test results relative to material performance, including recommendations for primers and substrate preparation required to obtain adhesion. The chemical compatibility of all glazing materials and framing sealants with each other, and with like materials used in glass fabrication must be established. This is required on every project.
6. **U.S. ALUMINUM.** It is the responsibility of U.S. Aluminum to supply a system to meet the architect's specifications.

# INSTALLATION INSTRUCTIONS

## FRAME FABRICATION

Most of the details shown on these instructions are for 1" (25) glazing and 4" (102) back members. Details for 1/4" (6) glazing systems and 5" (127) and 8" (203) back members are similar.

1. Cut members to size:

**Wall Jambs and Intermediate:** R.O. minus top and bottom clearances (F.D.)  
(See page 19 and 20 for vertical splice joints)

**Wall Jamb Pressure Bar:** F.D. Minus 1/4" (6.4)

**Wall Jamb Face Cover:** F.D. Minus 1/32" (0.8)

**Horizontal Members:** D.L.O. Minus 1/32" (0.8)

**Horizontal Pressure Bars:** F.D. Minus 5-1/4" (133)  
(See page 17 for splice joint considerations)

**Horizontal Face Cap:** F.D. Minus 5-1/16" (129)  
(See page 17 for splice joint considerations)

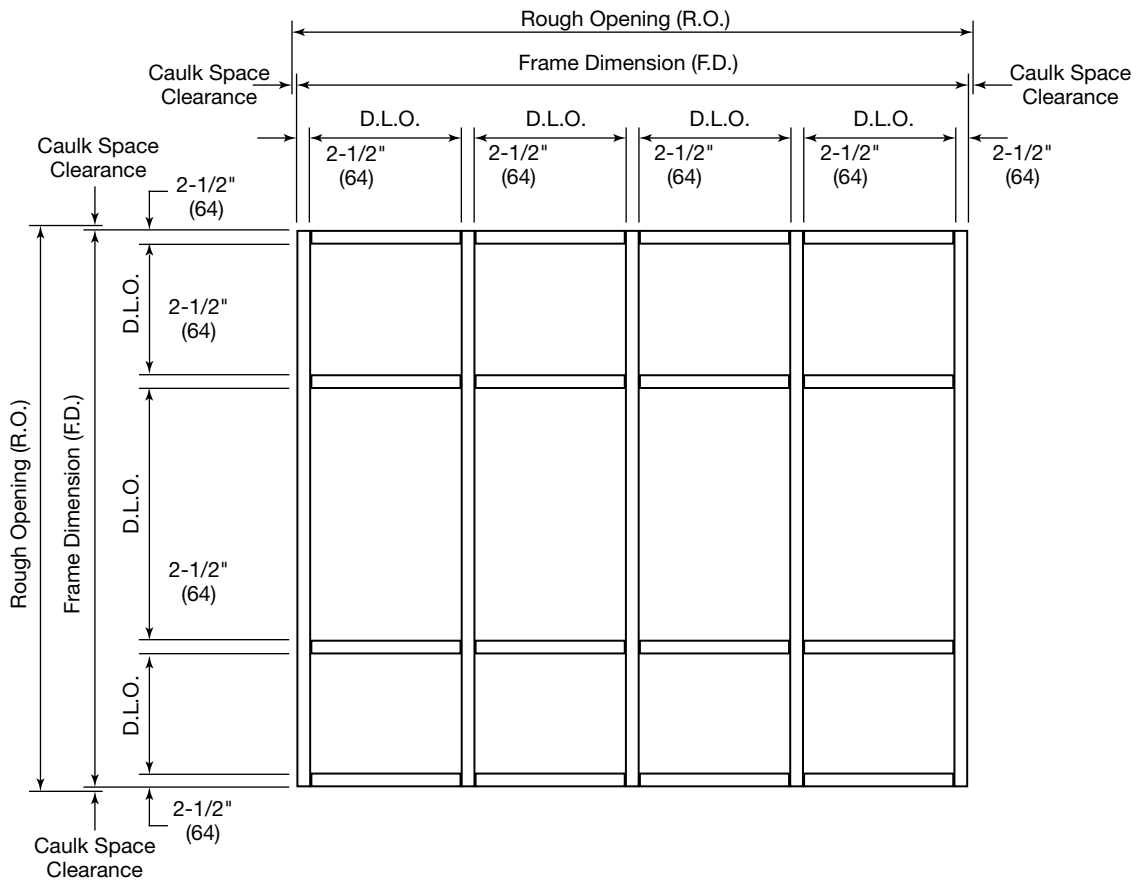

TYPICAL ELEVATION

NOT TO SCALE

# SERIES 3150 CURTAIN WALL

2. Mark on verticals the location of horizontal members and drill holes for Shear Blocks. Drill Jigs are available. See **DETAIL A**. Visit [usalum.com](http://usalum.com) for additional information.

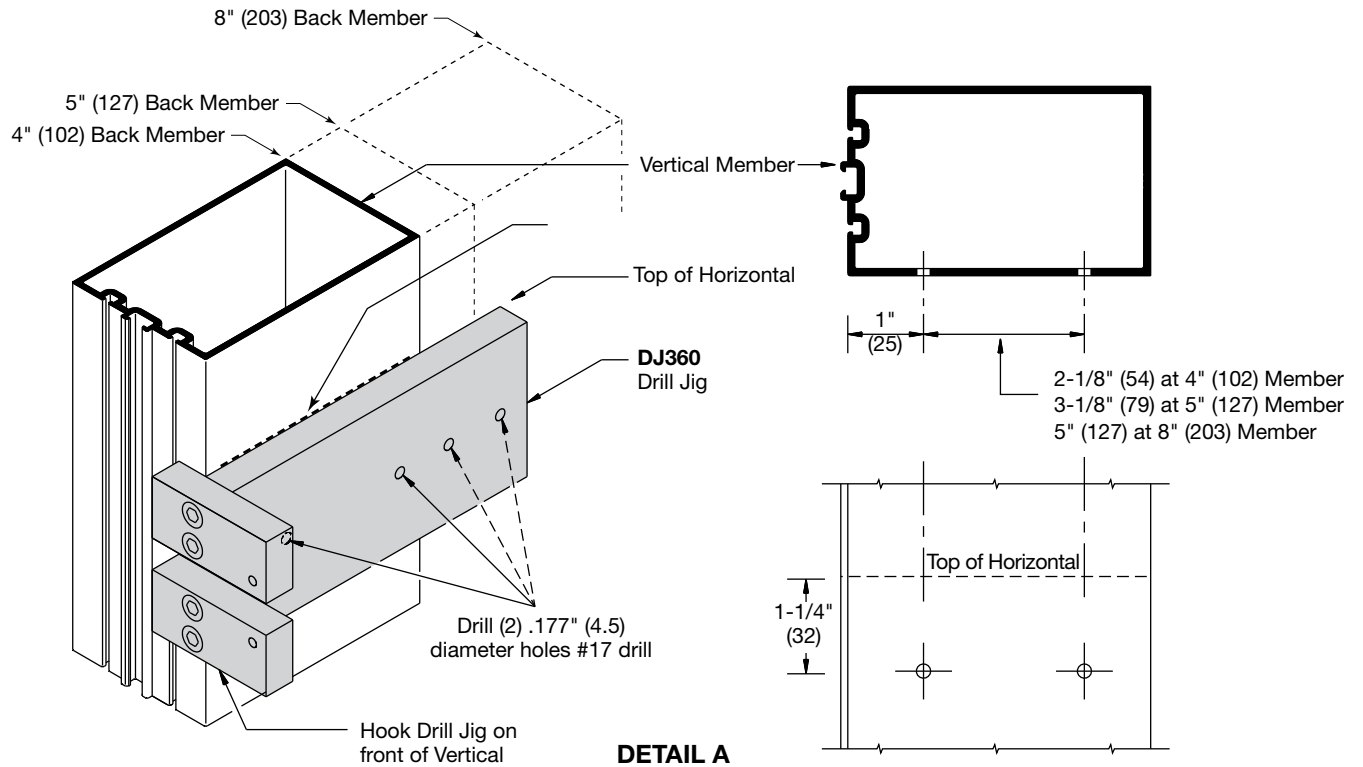

3. Fabricate ends of horizontal members for shear blocks pick-up screws. See **DETAIL B**.

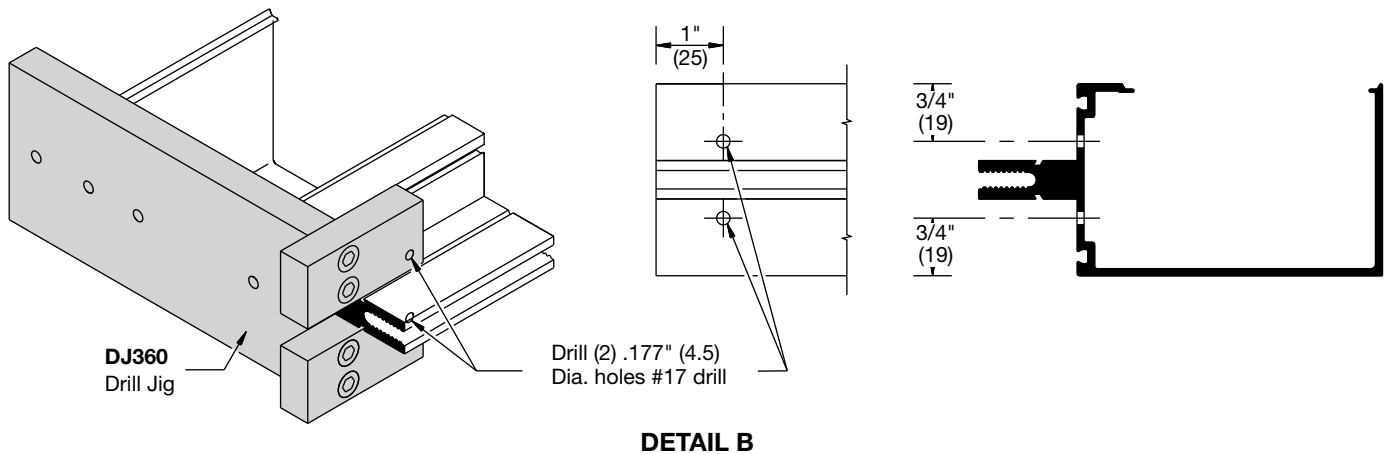

4. Fabricate bottom of Face Caps for weep holes 6" (152) from each end and 6" (152) each side of Mullions. See **DETAIL C**.

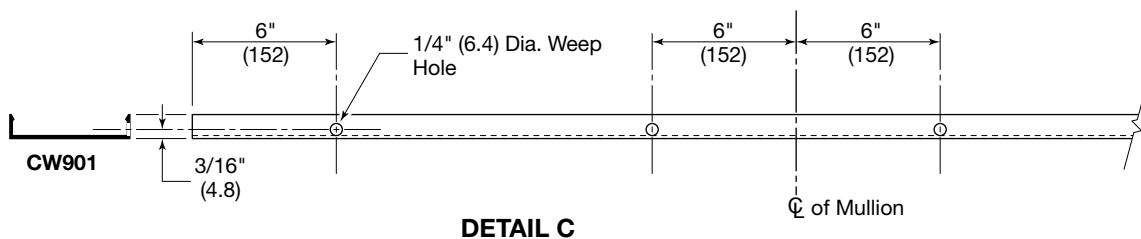

NOT TO SCALE

# SERIES 3150 CURTAIN WALL

- Jamb Pressure Bars are provided with 9/32" (7) dia. attachment holes spaced at 9" (229) on center. Additional holes should be drilled at 1-1/2" (38) from each end and 1-1/2" (38) from each edge of horizontal locations.
- Horizontal pressure bars are factory punched for attachment hole at 9" (229) on center. Additional holes should be drilled at 1-1/2" (38) from all ends and at vertical/horizontal intersections. **See DETAIL D.**
- Fabricate (2) 1/4" x 1-1/2" (6.4 x 38) weep slots in horizontal pressure bars. **See DETAIL D.**  
**NOTE:** Intermediate horizontal pressure bars run continuous between wall jambs. Splice joints are required at long run elevations. **See DETAILS W and X** on pages 16 and 17.

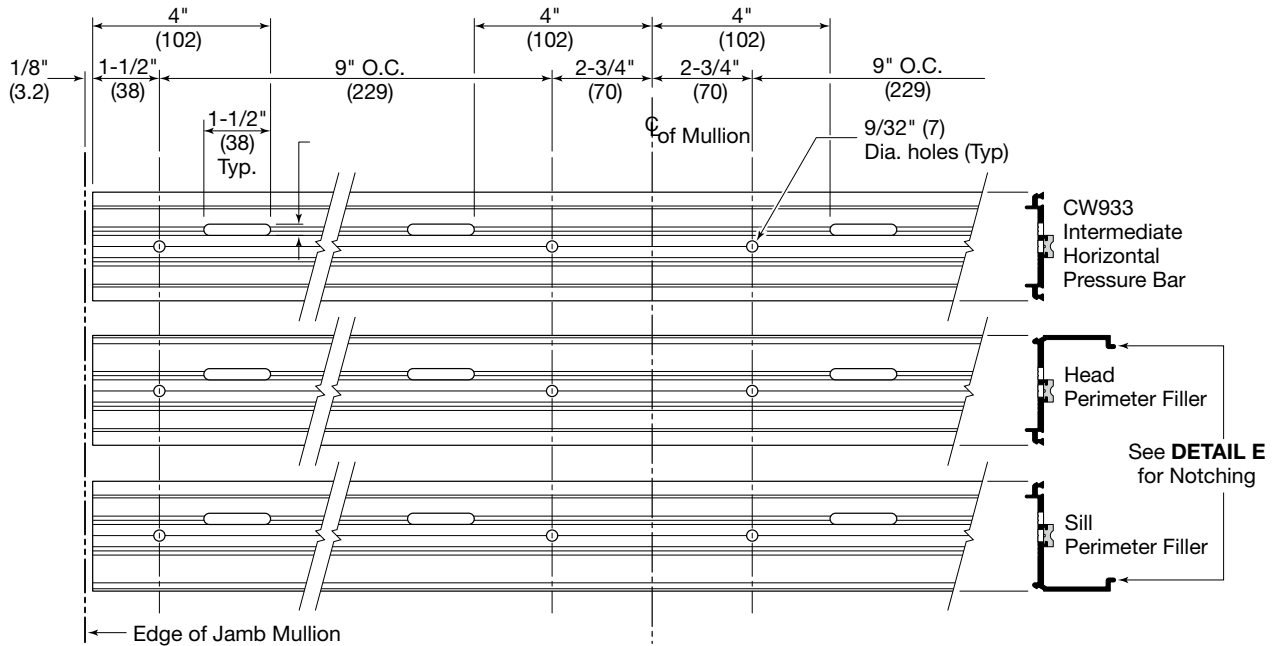

**DETAIL D**

- Notch head and sill pressure bar leg as shown in **DETAIL E** for mullion clearance.

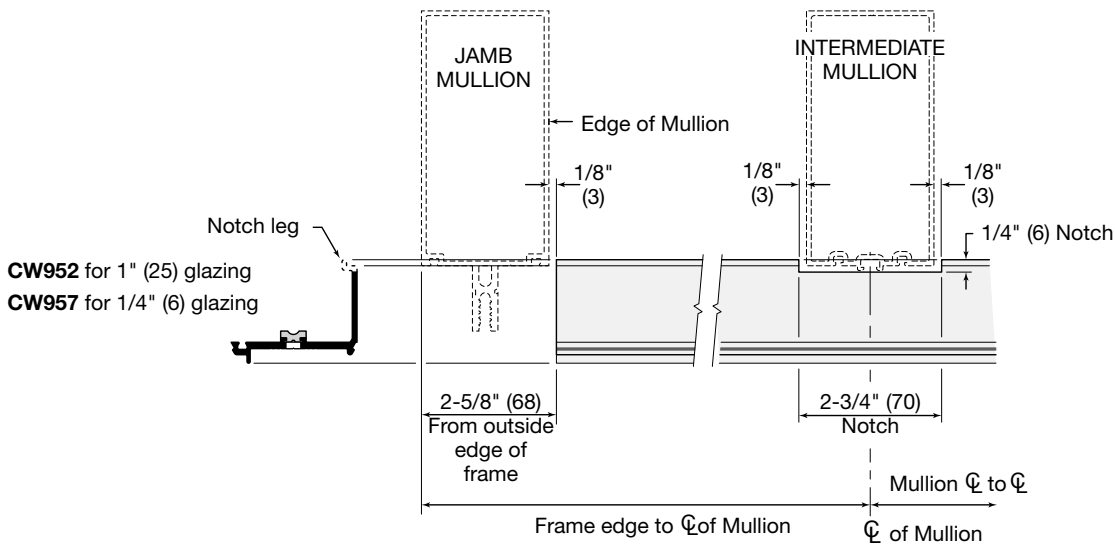

**DETAIL E**

NOT TO SCALE

# FRAME INSTALLATION

## SINGLE SPAN CONDITION

- Slide top and bottom anchors into vertical members. See **DETAIL F** for anchor types.
- Install verticals plumb and level. Shim directly under each side of each vertical as shown in **DETAIL F** for proper caulk joint and leveling. Secure top and bottom anchors to structure.

### INTERMEDIATE VERTICALS

Use **AP994** for 4" (102) Members  
**AP995** for 5" (127) Members  
**AP998** for 8" (203) Members  
 (Typical top and bottom)

### WALL JAMBS

Use **AP974** for 4" (102) Members  
**AP975** for 5" (127) Members  
**AP978** for 8" (203) Members  
 (Typical top and bottom)

**NOTE:** Aluminum anchors must be isolated from dissimilar materials. Typ. at top and bottom

**Field Drill Anchor Holes:**  
 Refer to approved shop drawings for anchor hole size and locations. Two fasteners per anchor. (Typical)

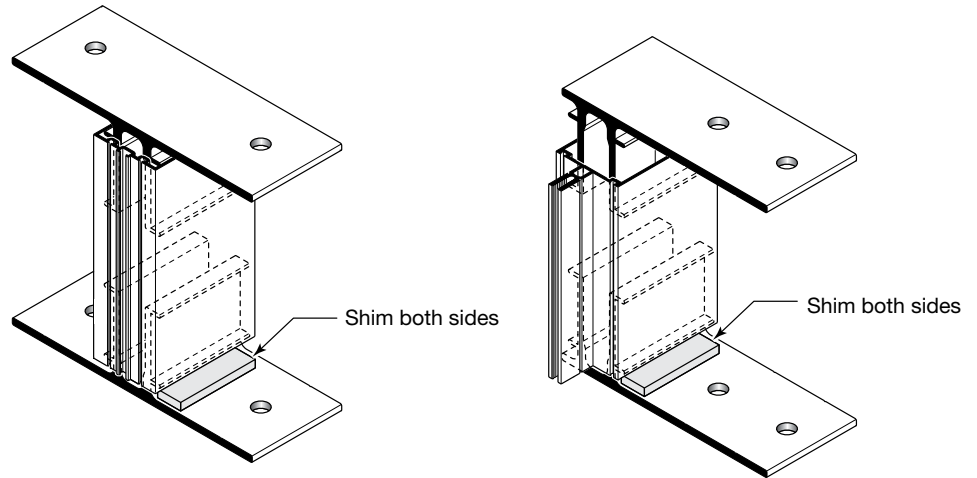

**DETAIL F**

- Attach shear blocks to verticals with screws provided. See **DETAILS G** and **H** for shear block positions. 4" (102) and 5" (127) horizontals shown.

**NOTE:** Use tubular horizontals when span exceeds 6'-0" (1.8 m) or deadload exceeds 250 lbs. (113.4 Kg) Elevations using tubular horizontals must be installed per bay. See tubular horizontal notes at **DETAILS H** and **I**.

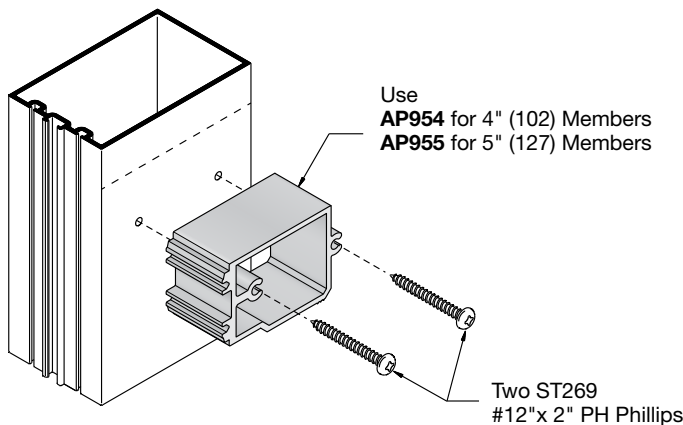

**DETAIL G**

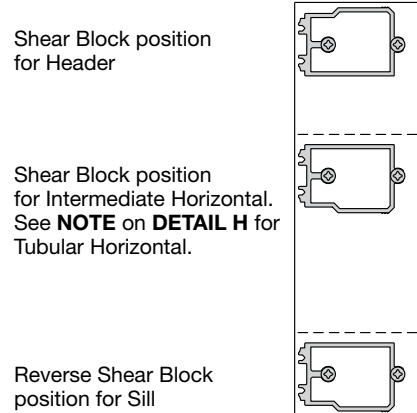

NOT TO SCALE



# 8" HORIZONTALS

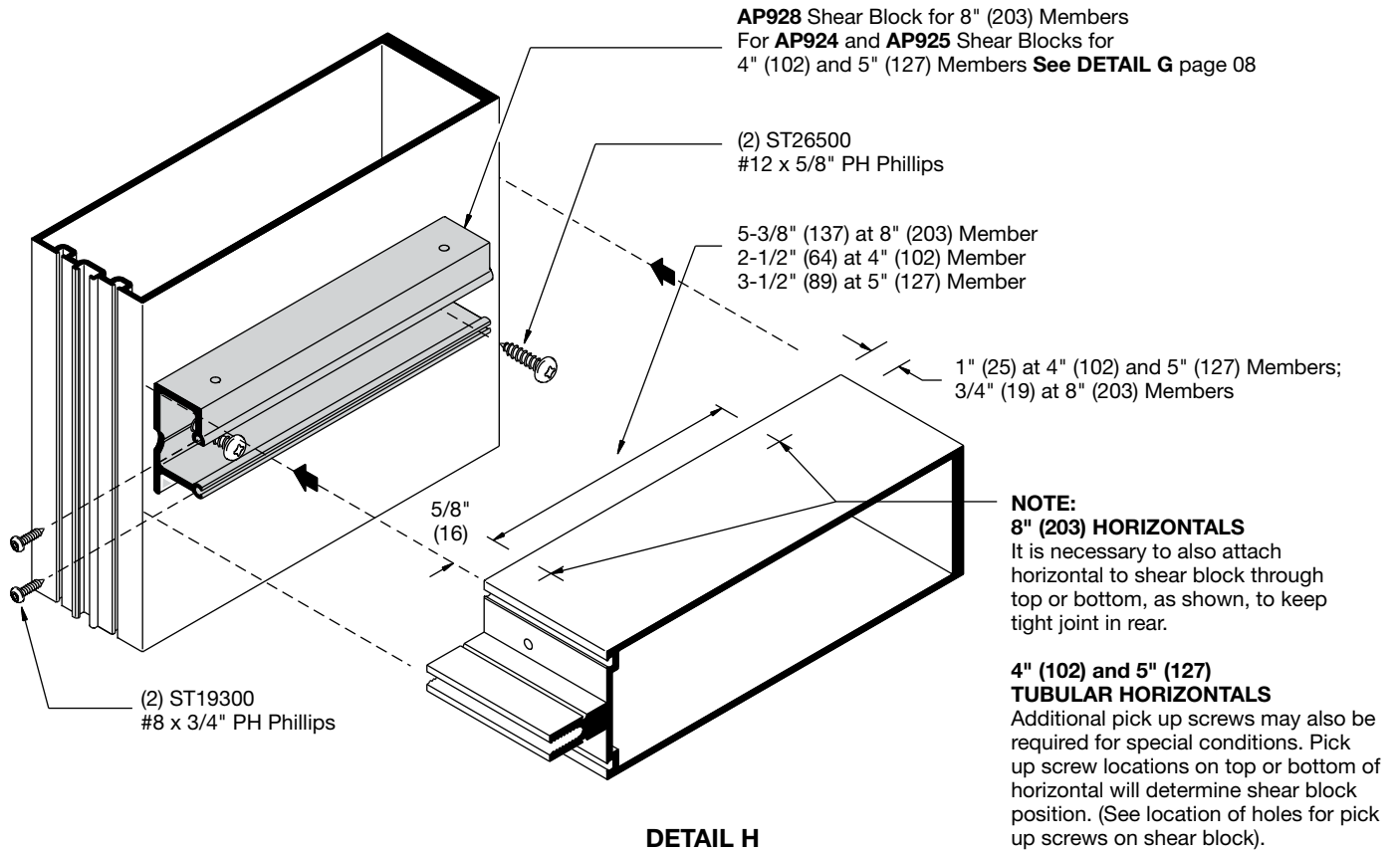

**NOTE:** If project requires tubular horizontals, fabricate heads and sills as shown in **DETAIL I**.

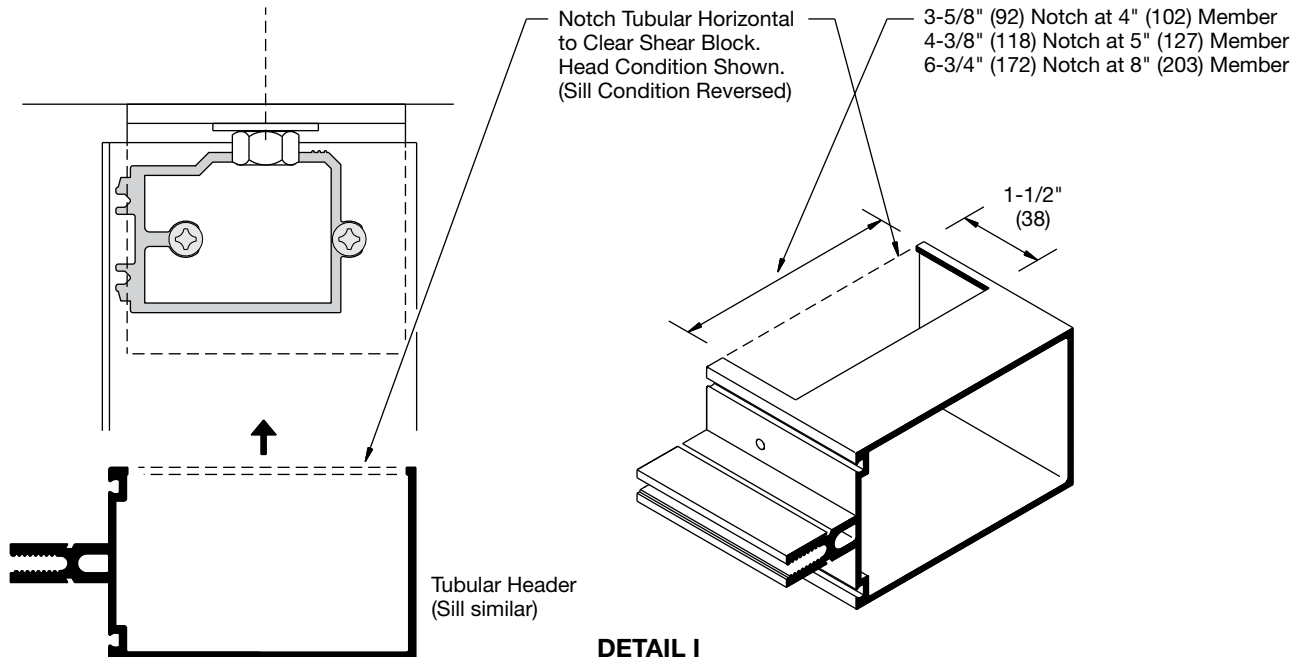

NOT TO SCALE

## MULTI-SPAN CONDITION

**DETAILS J and K** show fixed (deadload) and expansion (windload) anchors. Anchor type and size vary per job requirement. Details shown are to be used as a guide only. See approved shop drawings for actual conditions.

**NOTE:** Anchor type and sizes vary per job requirements. Details shown are to be used as a guide only. See approved shop drawings for actual conditions.

4. Secure verticals to anchor clips after alignment has been completed.

**NOTE:** Mullion spacing must be held to within  $\pm 1/32"$  (0.8). Check overall frame dimension every four bays to monitor dimension build up.

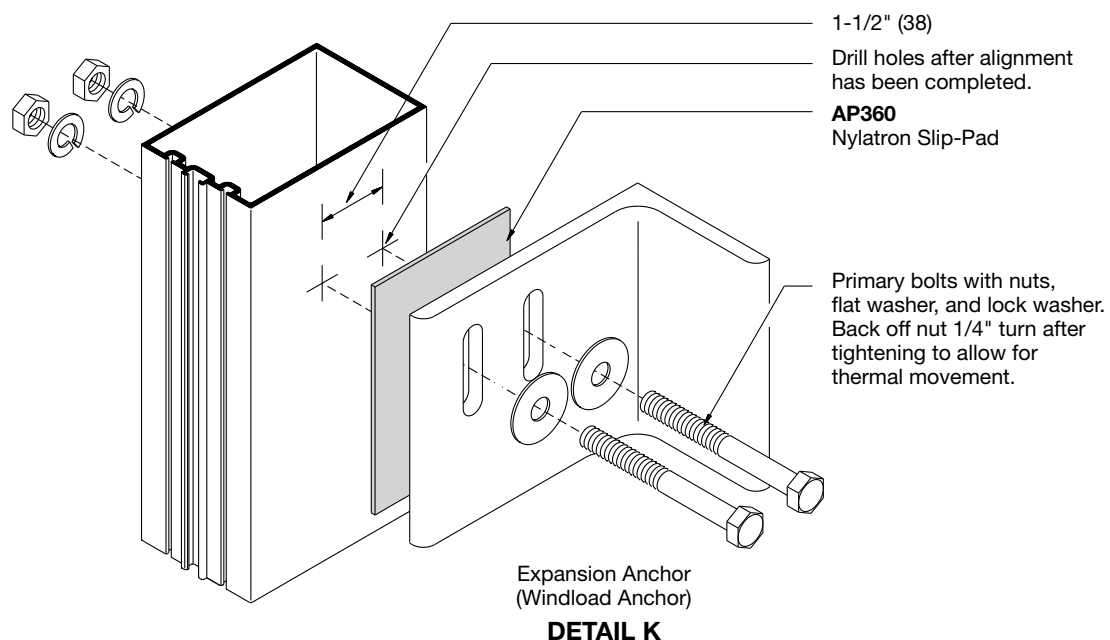
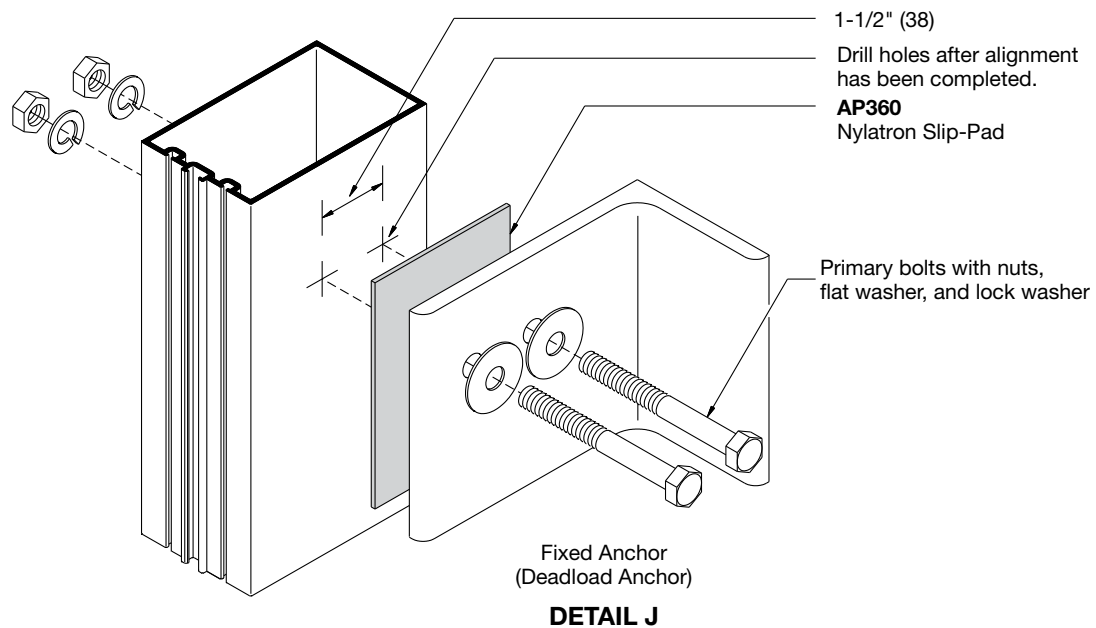

NOT TO SCALE

## OPEN BACK HORIZONTALS

5. Roll open back horizontal members over shear blocks and secure them with screws provided. See **DETAIL L**. Install snap-in horizontal filler where open back of horizontal member is exposed.

**NOTE:** Snap-in fillers are optional at head and sill to facilitate interior caulking. (Cut fillers short to clear shear blocks and snap them in before installing).

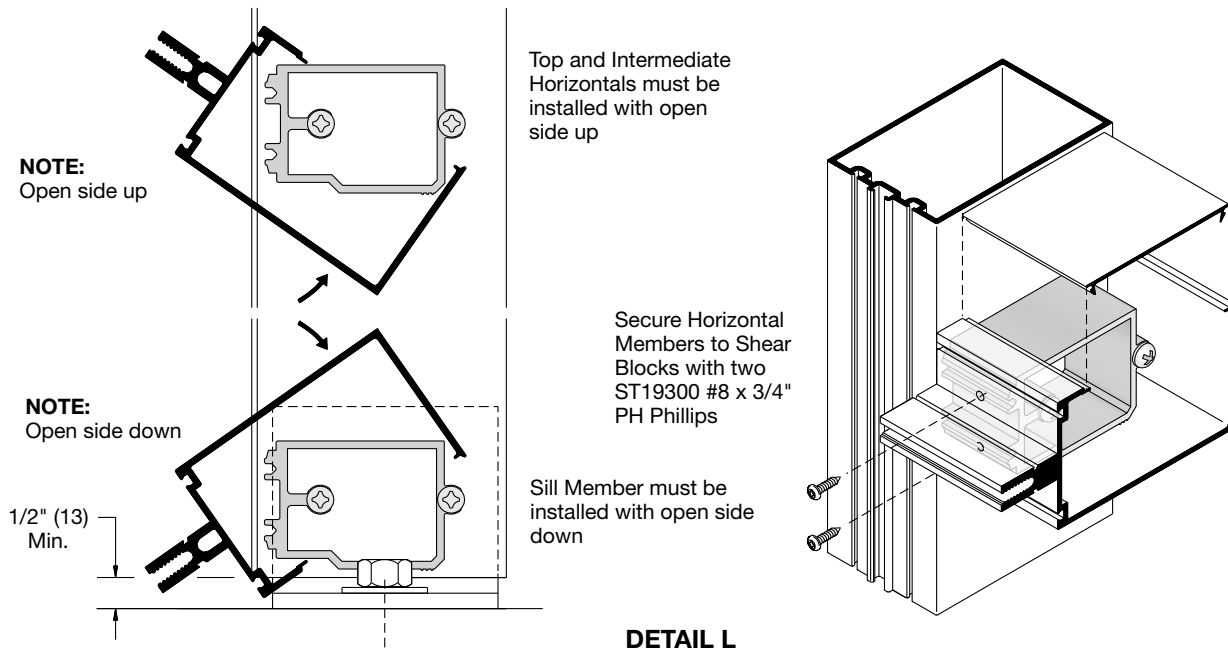

## TUBULAR HORIZONTALS

6. Slide horizontals over shear blocks and secure them with screws provided. See **DETAIL M**.

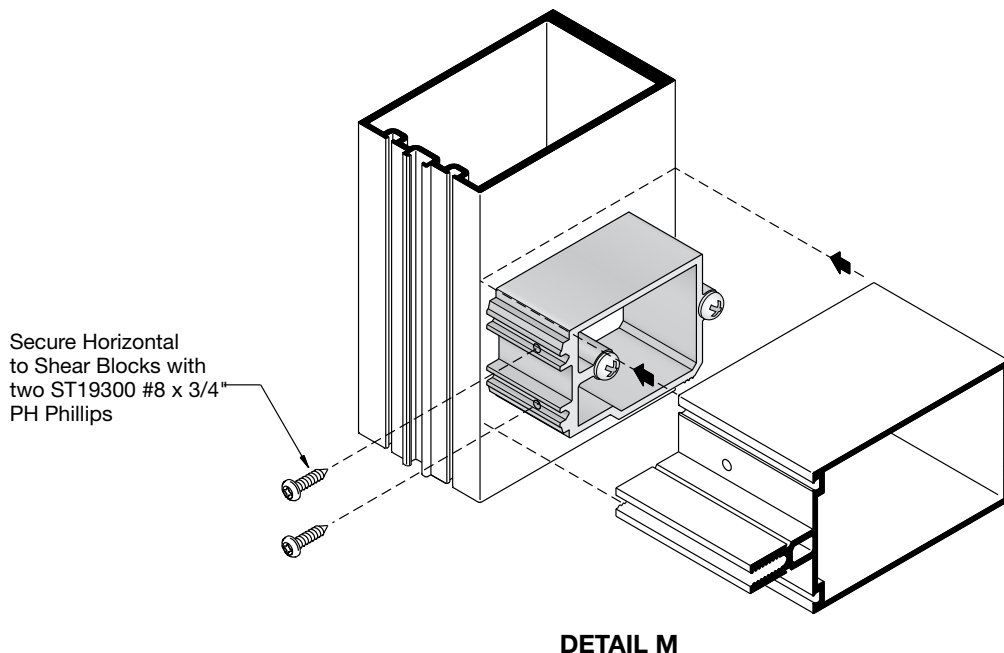

NOT TO SCALE

# SERIES 3150 CURTAIN WALL

7. Clean vertical and caps and cover areas of contact with silicone sealant as shown in **DETAIL N**.
8. Install end caps at top and bottom of wall jamb and intermediate verticals to ensure continuous perimeter caulking. See **DETAIL N**. Tool sealant.

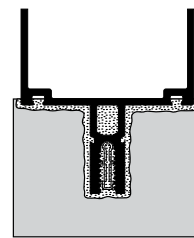
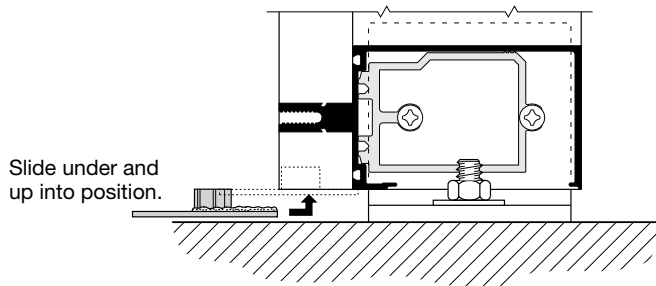
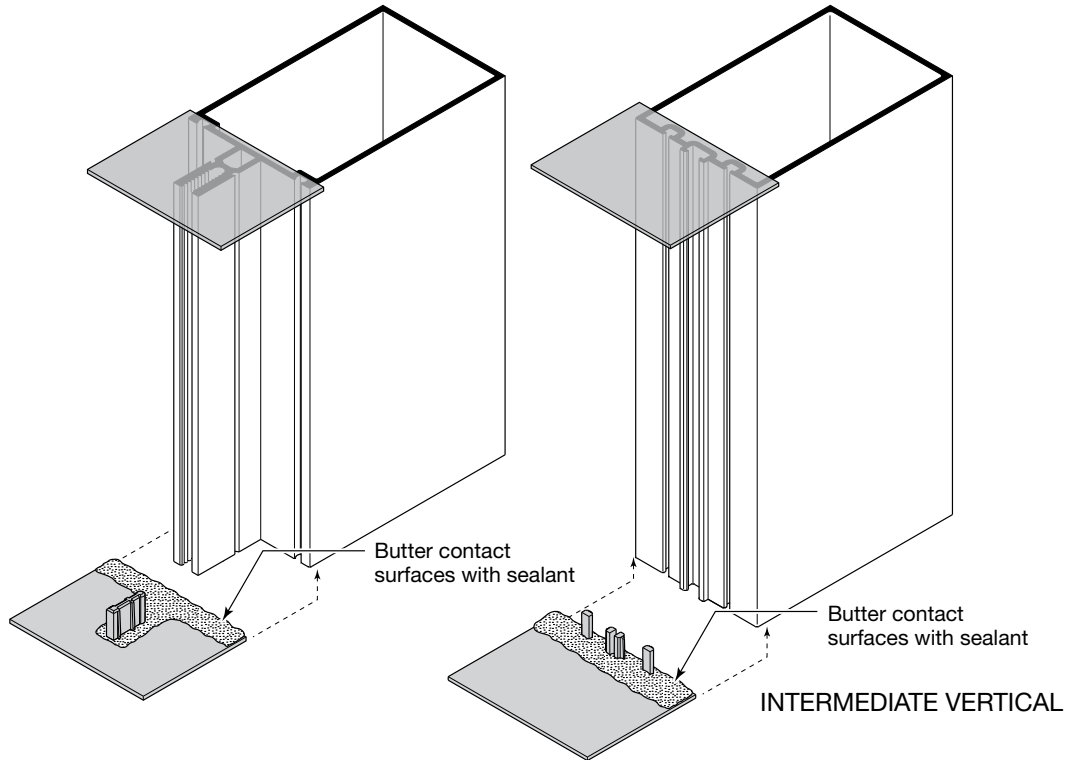

Use **CP925** for 1/4" (6) glazing  
Use **CP900** for 1" (25) glazing  
at wall jambs

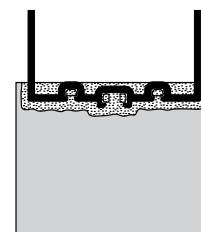
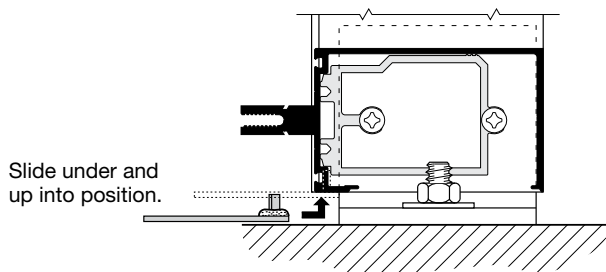

Use **CP950** for 1/4" (6) glazing  
Use **CP951** for 1" (25) glazing  
at Intermediate Verticals

**DETAIL N**

NOT TO SCALE

# SERIES 3150 CURTAIN WALL

- Once all verticals and perimeter members are installed, apply M64 or M66 seal around perimeter. Perimeter caulking must be completed prior to installation of glass and pressure bars. Ensure perimeter sealant has smooth transition across vertical End Dams. **See DETAIL O.**

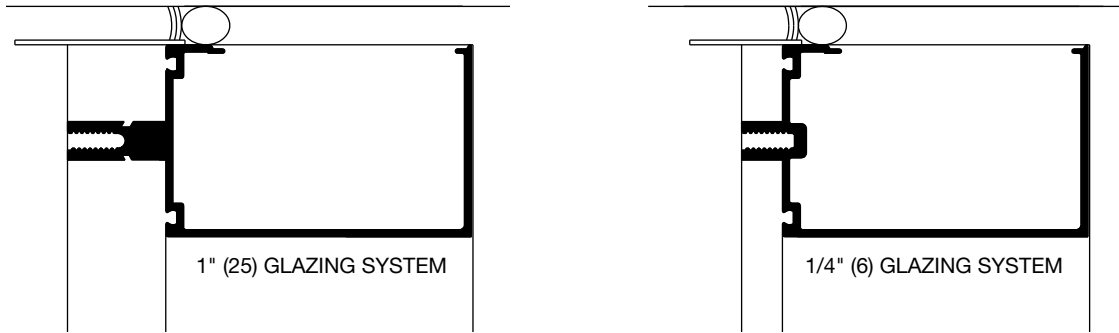

**DETAIL O**

- Using CRL RTV408, seal joints between horizontals and verticals and over heads of screws in the glazing pockets. **See DETAIL P.**
- Using CRL RTV408, apply sealant at the three contact areas of End and Intermediate Dams and to all areas shown on **DETAIL P** just prior to installation. Slide End Dams and Water Deflectors into place. Seal joints and tool sealant. **NOTE:** End and Intermediate Dams occur at head and sill also.

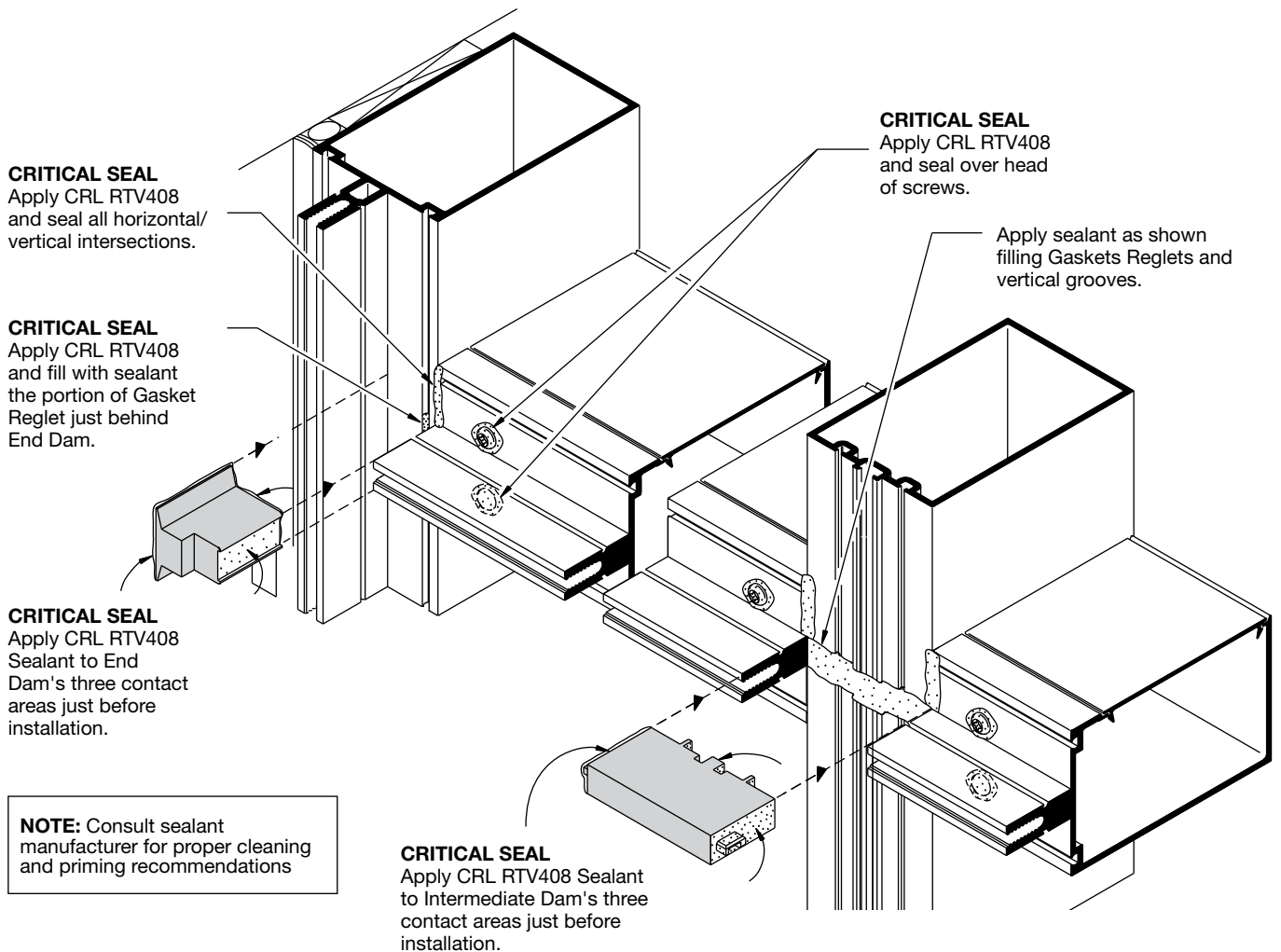

**DETAIL P**

NOT TO SCALE

# GLAZING

## GLASS SIZES

**GLASS HEIGHT: DAYLIGHT OPENING + 1" (25)**  
**GLASS WIDTH : DAYLIGHT OPENING + Glass Lites**

Glass lite at vertical members vary. **See DETAIL Q**

**NOTE:** These formulae do not take into account glass tolerances. Consult glass manufacturer before ordering glass.

Glass sizes for corner lites or special conditions must be calculated as per approved drawings. Remove gaskets from carton and lay flat in a clean, dry area in order to allow the gaskets to recover their shape. Allow the gaskets to relax at least two hours at temperatures above 50°F (10°C). Glaze with gaskets above 40°F (4°C). If necessary, warm gaskets in a hot box before installing. Use NP430 dense Gasket at exterior and NP420 sponge Gasket at interior for wall jambs and horizontal members. Use SP450 Glass Spacer for intermediate verticals.

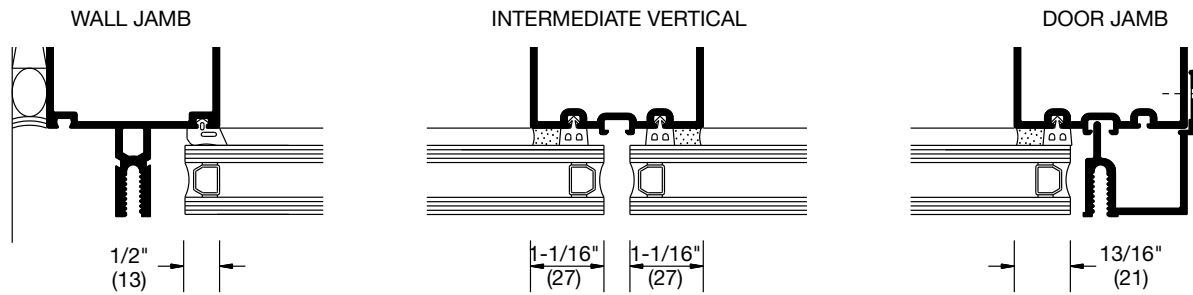

**DETAIL Q**

1. Cut gaskets allowing 1/8" (3) extra length per foot of extrusion to allow for shrinkage. Vertical gaskets on mullion run past horizontal gaskets by 5/8" (16). **See DETAIL R** horizontal gaskets run between verticals.
2. Install back gaskets into vertical and horizontal members. Just prior to glazing fill with sealant the void between vertical and horizontal gaskets at intermediate verticals. Also apply sealant to interior gaskets corner at wall jamb/horizontal intersection 2" (51) in each direction. **See DETAIL R.**
3. Install front gaskets into pressure bars. Wall jamb pressure bar gaskets run continuous; **Horizontal pressure bar gaskets should extend 1/8" (3) beyond ends of extrusions.**
4. Position two setting blocks for each glass lite, as directed by deadload charts and shop drawings.

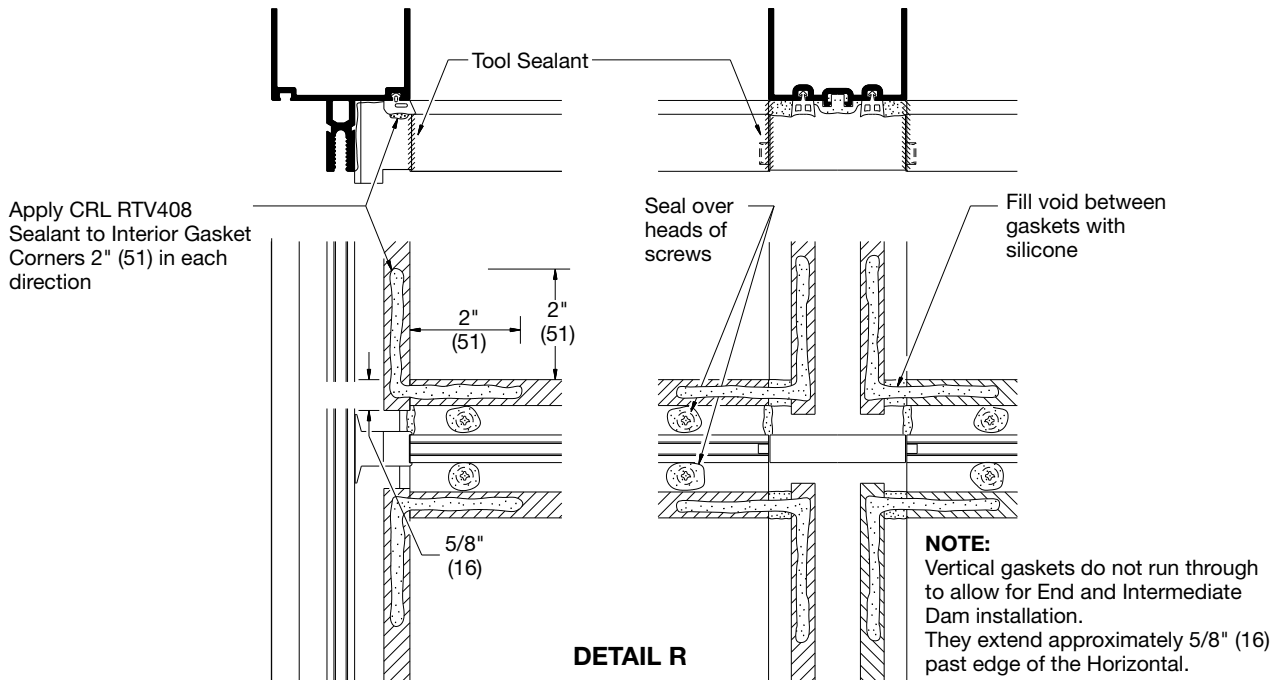

**DETAIL R**

NOT TO SCALE

## SERIES 3150 CURTAIN WALL

5. Install glass in place and center in opening. Support glass with Temporary Retainers. Use CW368 for wall jambs and RG635 for intermediate verticals. **See DETAIL S.** RG635 should remain in place until structural silicone has fully cured as required by silicone manufacturer's recommendations.

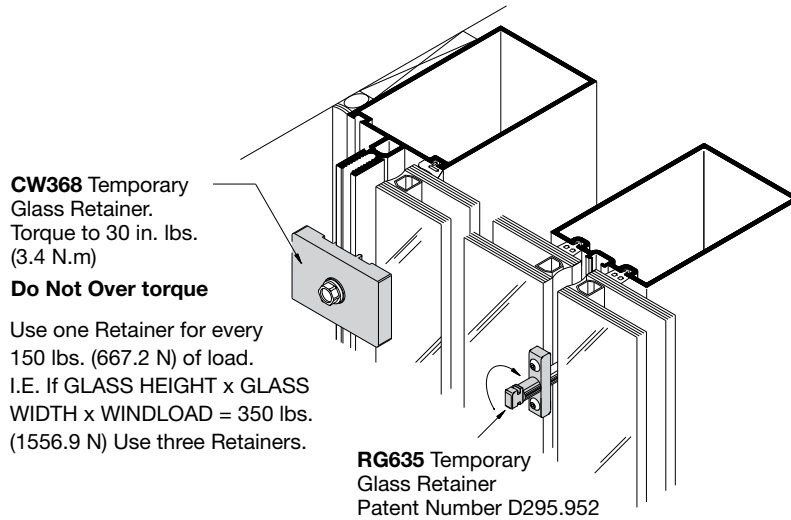

6. Apply CRL RTV408 Sealant to face of End and Intermediate Dams just prior to installing the pressure bars. **See DETAIL T.**

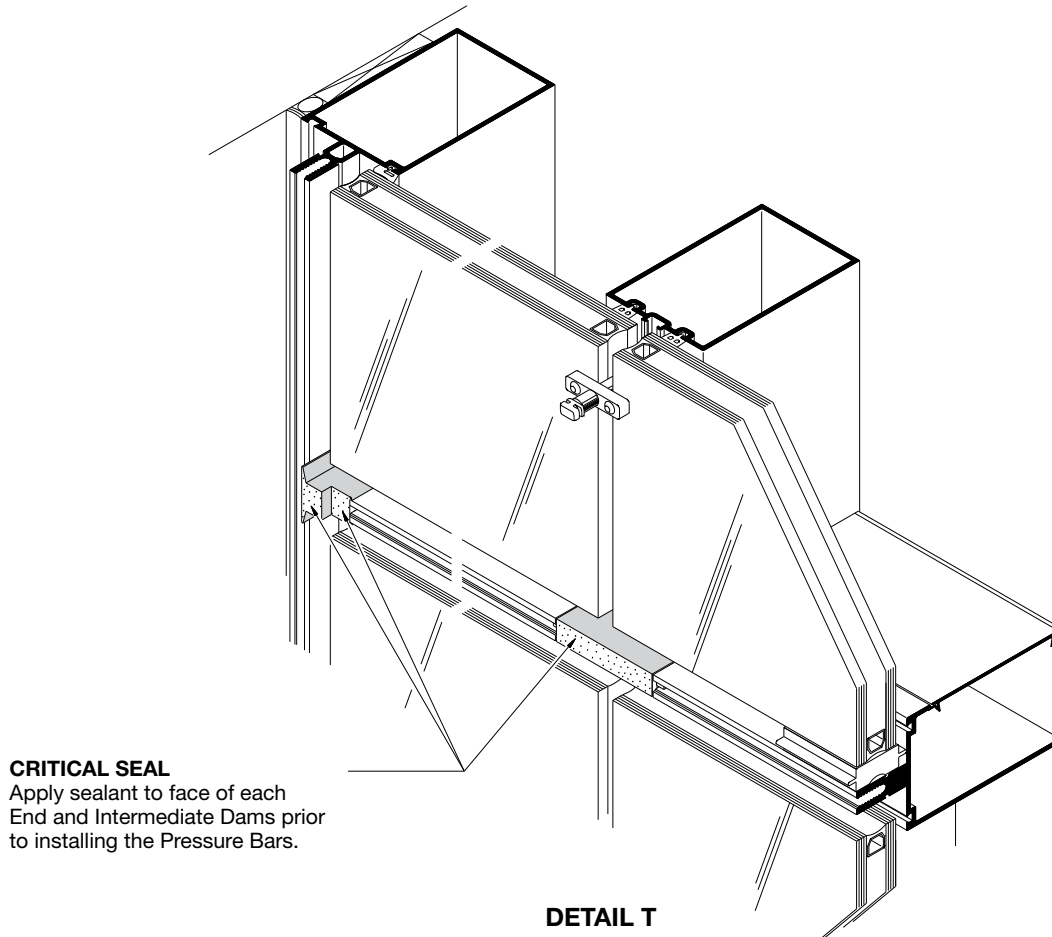

NOT TO SCALE

## PRESSURE BAR INSTALLATION

Install wall jamb pressure bar bolts from bottom to top and horizontal pressure bar bolts from center outward.

7. Install wall jamb pressure bars first leaving 1/8" (3) gaps at top and bottom. Using a torque wrench, torque bolts to 30 inch pound (3.4 N). Increase torque to 50 to 60 inch pound (5.7 to 6.8 N) after all four sides have been secured.
8. Center horizontal pressure bars in opening leaving 1/8" (3) gaps at ends and 1/2" (13) at splice joints.  
**See DETAIL U. Be sure pressure bar spacer is not disengaged.**  
**NOTE:** Weep slots must be on top side and level with bottom of glazing pocket to ensure proper drainage.
9. Seal gaps at wall jamb/horizontal intersections, top and bottom of wall jambs, pressure bars, and splice joints. Tool sealant. **See DETAIL U.**

**NOTE (Horizontal Pressure Bar):** If pre punched attachment hole occurs at intermediate mullion location, hole must be sealed as follows: Clean area around hole. Inject small amount of silicone sealant into hole then apply 3/4" (19) diameter bead of sealant over hole and tool.

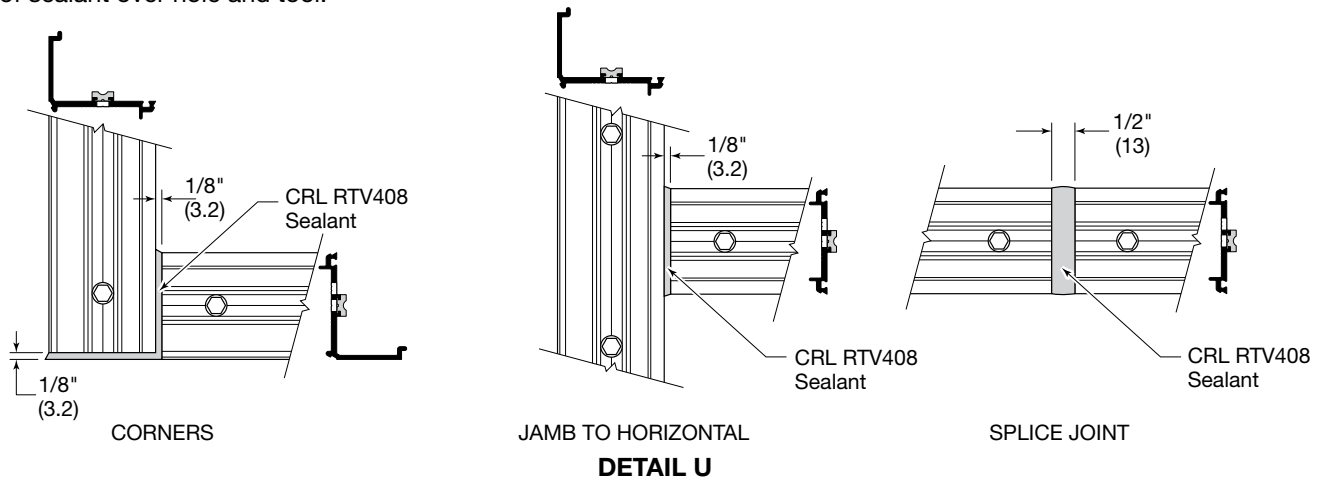

## FACE COVER INSTALLATION

Care must be taken to prevent damage of Face Covers during installation. Use a piece of wood such as 2" x 4" x 12" (51 x 102 x 305) and a 3" (76) diameter Stanley three pound (1.3 N) Compo-Cast Dead Blow Soft Face Hammer.

10. Install Wall Jamb Face Covers first. Do not disturb vertical's top and bottom closure plates when installing face covers. Pinning of wall jamb face covers is required to prevent slippage. Use one pin per cut length, concealed behind horizontal face cover closer to center point or as shown on shop drawings. **See DETAIL V.**
11. Install Horizontal Face Covers with weep holes located on bottom side.  
**NOTE:** Extended face cover requires a special pressure bar. Pin wall jamb extended covers with one 1/2" (13) dia. pop rivet per stock length. Extended horizontal face caps must be pinned on top side with 1/2" (13) dia. pop rivets at 6'-0" (1.83 m) maximum (optional #10 x 1/2" FHSMS). **See DETAIL W.** Inject small amount of silicone sealant into hole then apply 3/4" (19) Dia. bead of sealant over hole and tool.

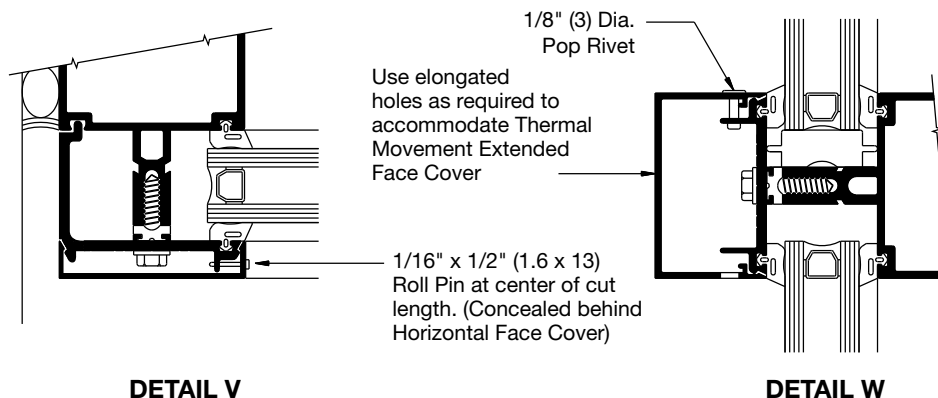

NOT TO SCALE



## STRUCTURAL SILICONE APPLICATION

- Structural silicone is applied from the interior. Follow silicone manufacturer's instructions and recommendations for surface preparation and silicone application.
- After structural silicone has fully cured, remove Temporary Glass Retainers from intermediate verticals. Insert open cell polyurethane rod between glass edges. Mask aluminum and glass adjacent to joint, and apply outside weatherseal.

## HORIZONTAL FACE COVER SPLICE JOINTS

Locate splice joints at centerline of vertical members.

Splice joint width should be based on formula for linear expansion for aluminum (page 19), specifications and sealant movement capability.

Do not align face cover splices with pressure bar splices. Offset 6" (152) minimum. **See DETAIL X.**  
Set backer rod between face cover and pressure bars at joint and seal. Tool sealant. **See DETAIL Y.**

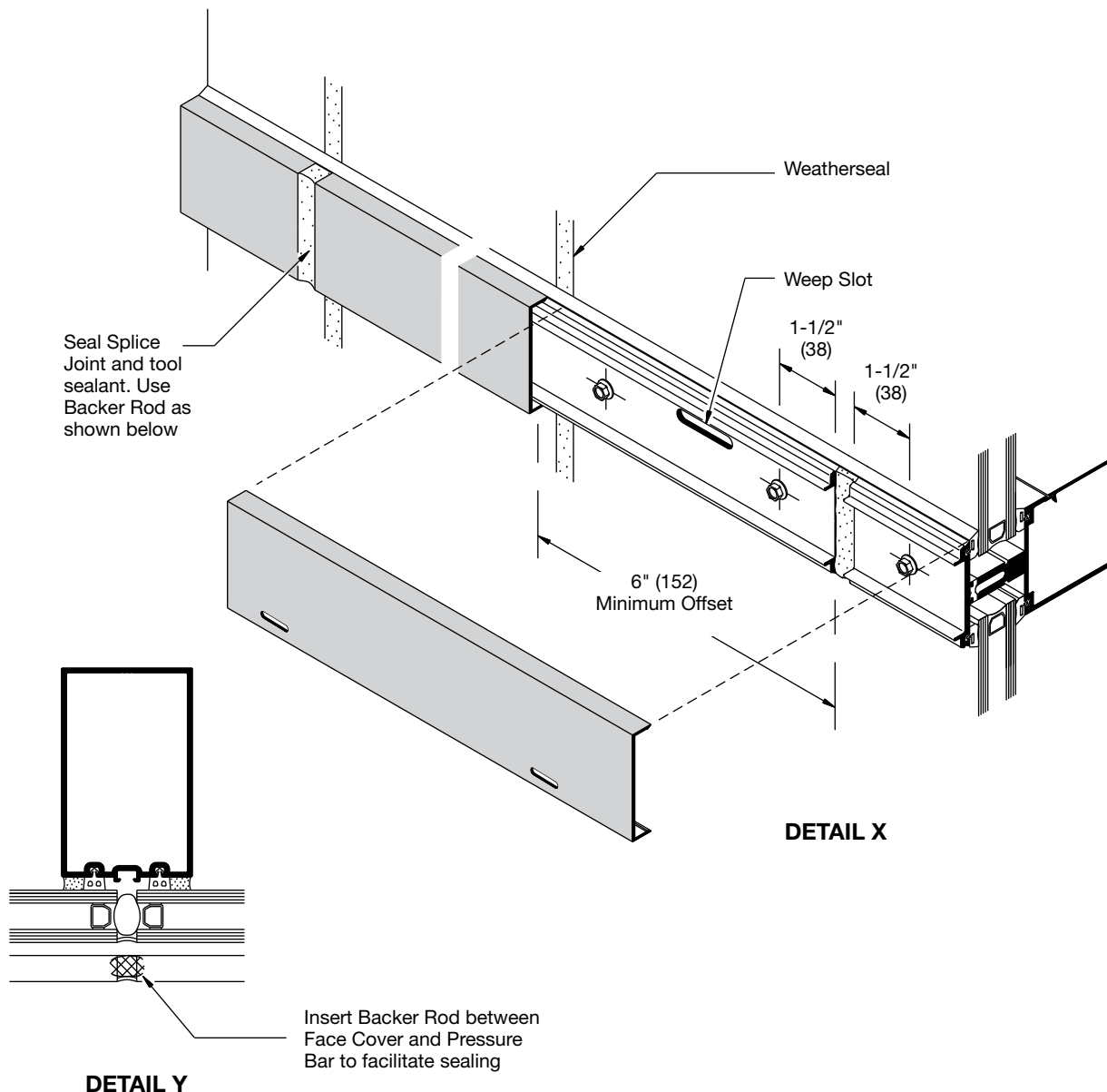

NOT TO SCALE

# TRANSITION GLAZING

1. Apply CRL RTV408 sealant into gasket reglets before installing snap-in transition adaptors.
2. Install vertical adaptors first.  
**NOTE:** Discontinue vertical adaptors at splice joints and locate fasteners 1-1/2" (38) each side of splice. Attach adaptors to back members with ST25400 #10 x 1-3/4" FHSS screws 1-1/2" (38) from ends and 24" (607) on center maximum.
3. Install snap-in horizontal adaptors and seal horizontal/vertical joints. Tool sealant. **See DETAIL Z.**

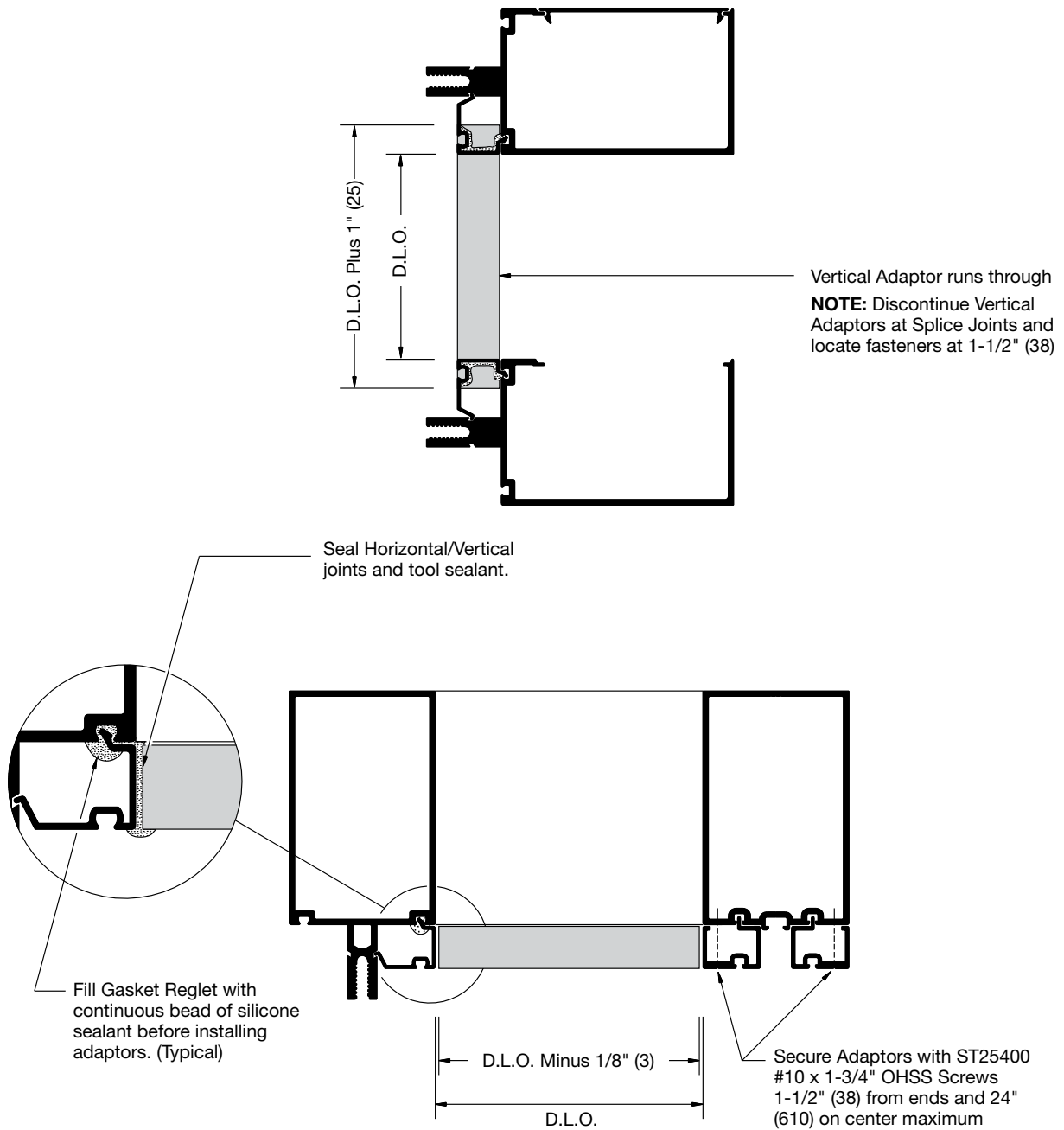

DETAIL Z

NOT TO SCALE

## VERTICAL SPLICE JOINTS

Splice joint width should be based on sealant movement capability and on the following formula:

Linear expansion for aluminum, in inches	=	Length (") x F° difference in temperature x .000129
Linear expansion for aluminum, in millimeters	=	Length (mm) x C° difference in temperature x .02322

A 1/2" (13) minimum joint is recommended. Use a 1/2" (13) spacer shim to set and hold the mullion joint constant during erection. Remove the shim after attaching the verticals to the anchors. **Splice joints must occur at spandrel areas.**

**NOTE:** Splice joints are designed to accommodate thermal movement only. They do not compensate for variations in floor levels.

1. Clean splice sleeves and all joint surfaces. Apply bond breaker tape at areas where sleeve will be sealed to avoid three side adhesion. **See DETAIL AA.**
2. Slide sleeve into the upper member before it is installed, and tape to hold it in retracted position. **See DETAIL AA.**
3. Install stop screw, 2-3/4" (70) down from top of extrusion centered on interior wall of lower member. **See DETAIL AA.**
4. Install upper member and let extruded sleeve slide down until it sits on top of stop screw.
5. Seal joint over sleeve as shown on **DETAIL AA.** When transition adaptors for 1/4" (6) spandrel are used they should be discontinued at splice joint and installed after splice joint is sealed.

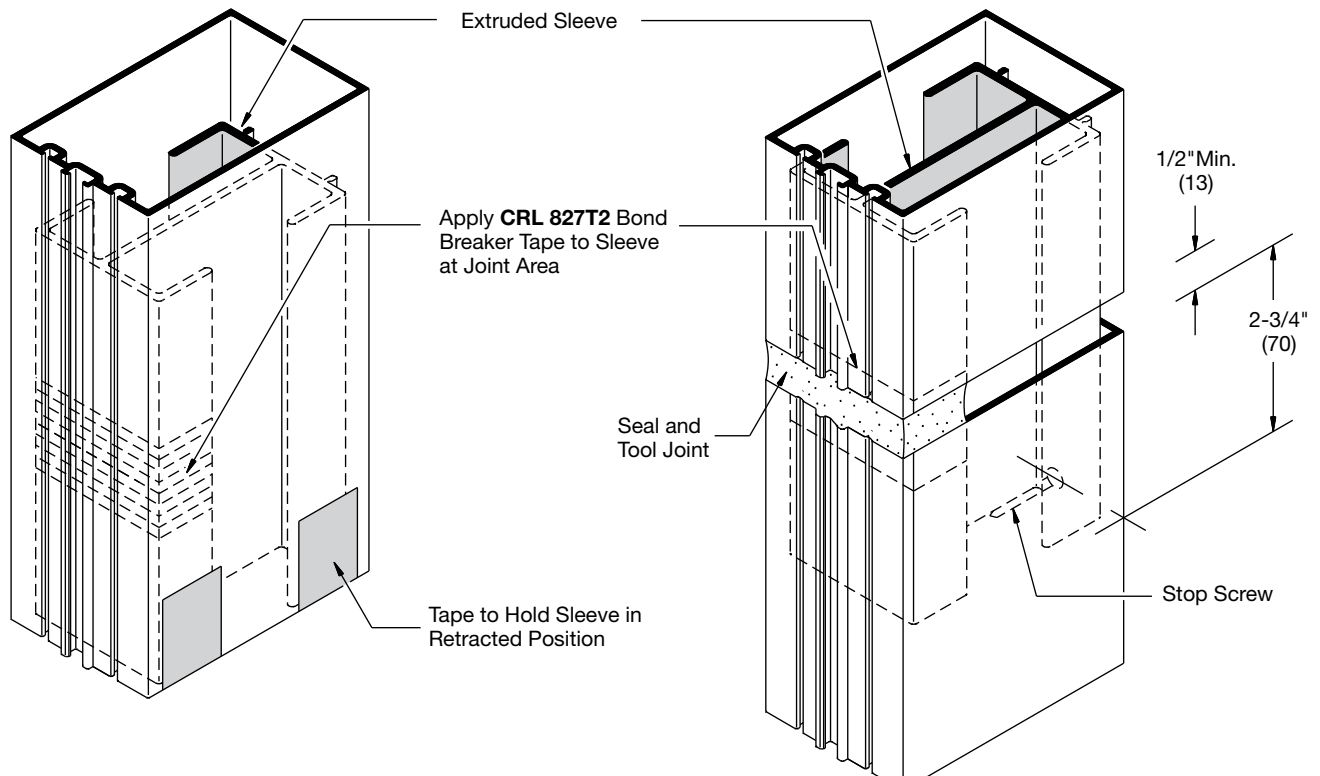

DETAIL AA

NOT TO SCALE

# WALL JAMBS SPLICE

Stagger joints on back member, pressure bar and face cap. See **DETAIL BB**.

6. Seal pressure bar joint. See **DETAIL CC**.
7. Install face cover and seal joint using backer rod as required. See **DETAIL BB**.

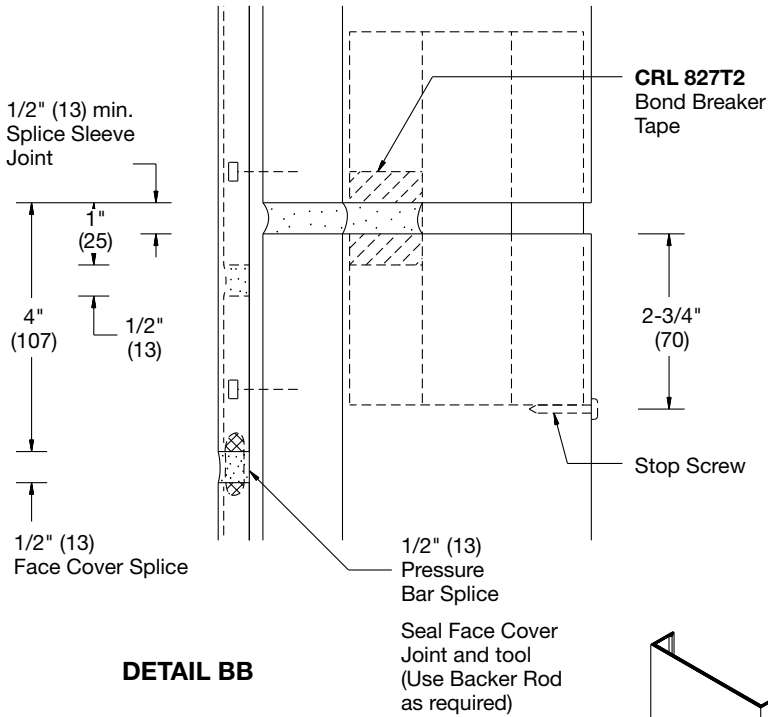
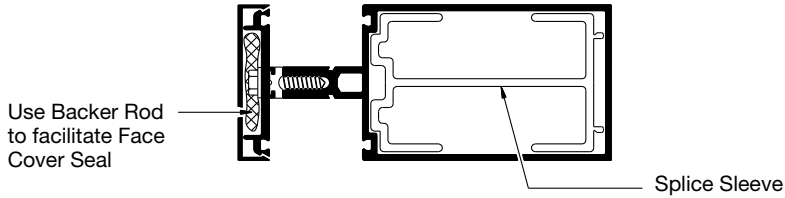

**DETAIL BB**

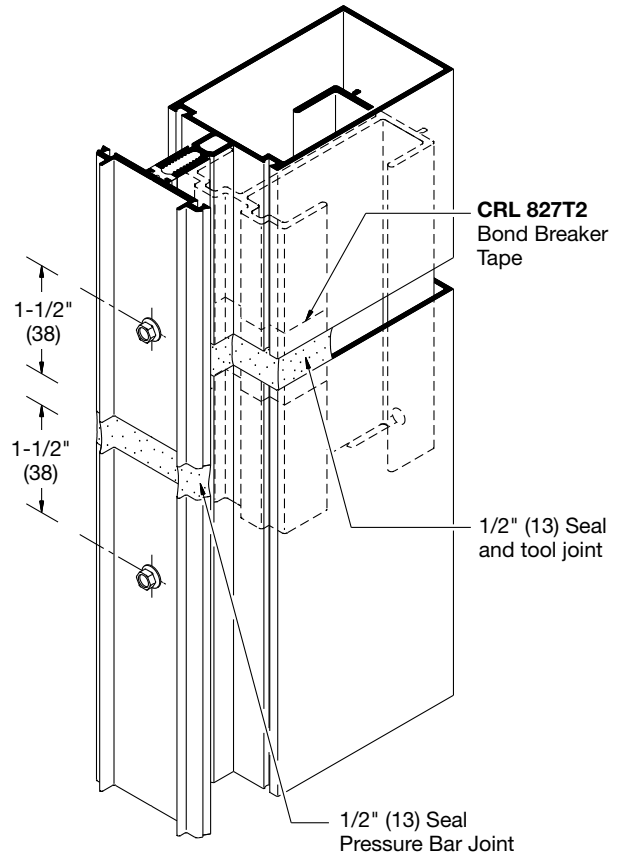
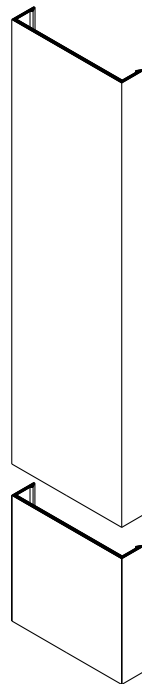

**DETAIL CC**

NOT TO SCALE

# ENTRANCE FRAMES

Entrance Frames may be installed simultaneously with Curtain Wall or after Curtain Wall installation has been completed.

Use CW928 or CW929 Pocket Fillers to close glazing pocket at door side.

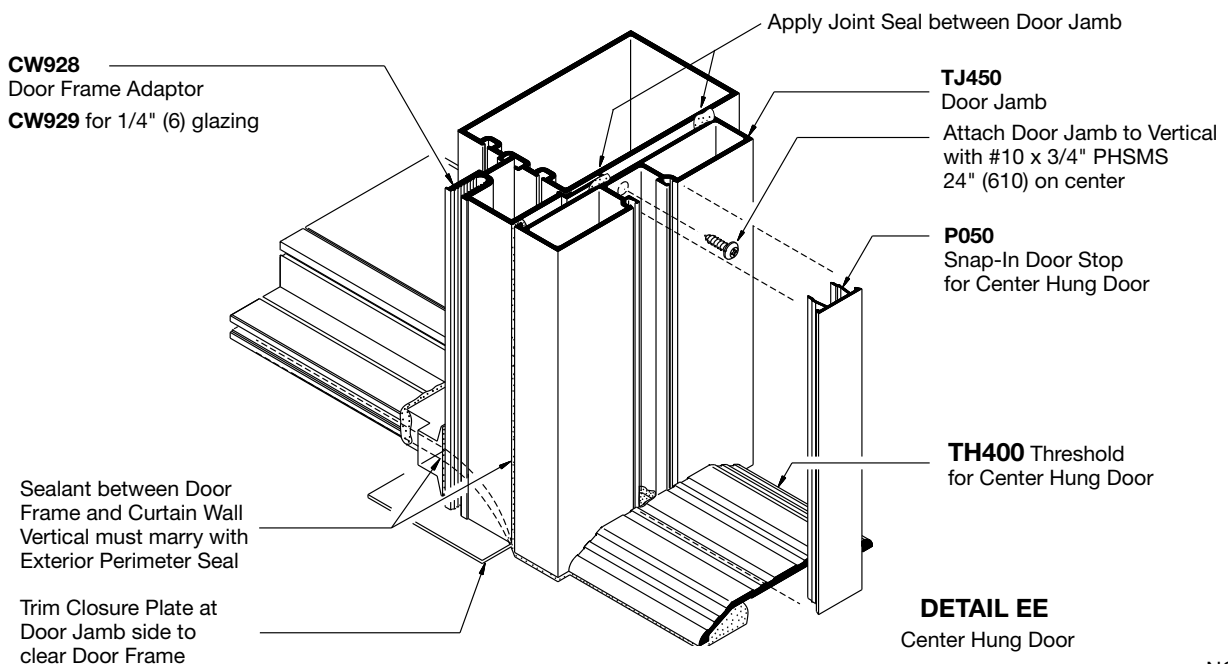
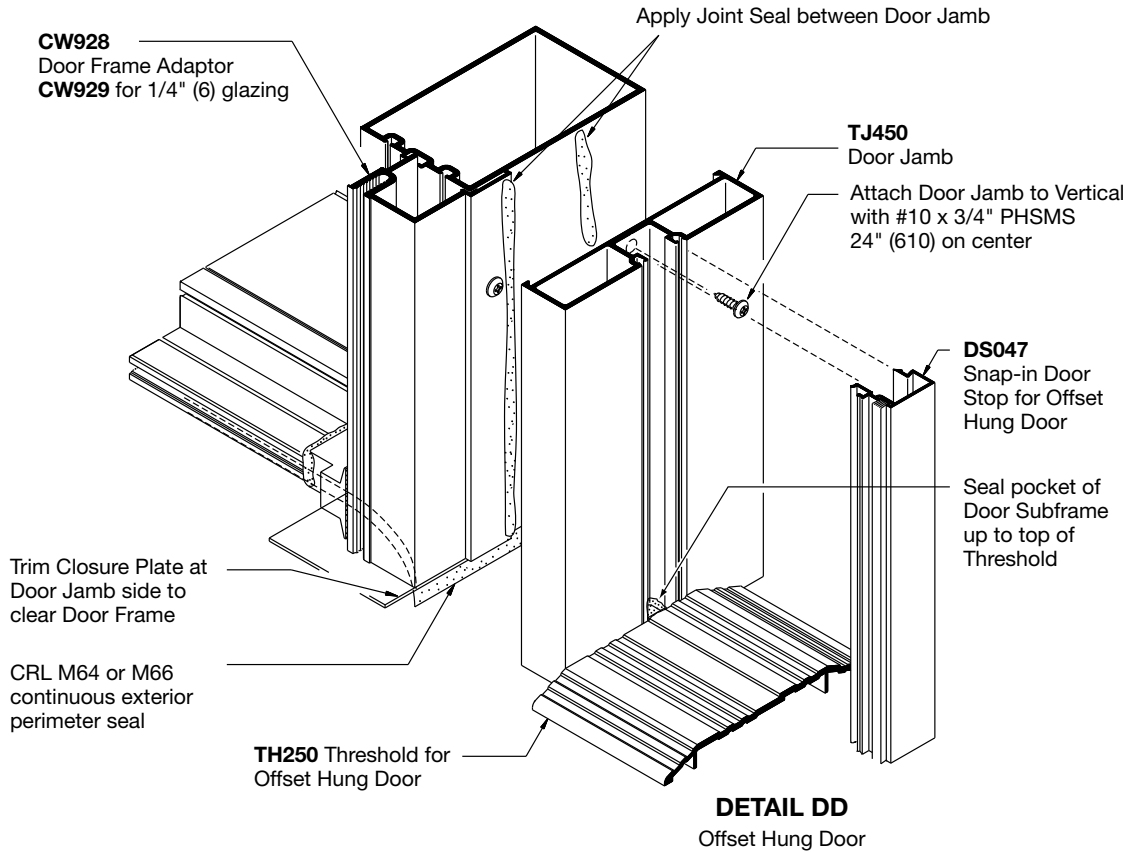

NOT TO SCALE

# ENL GUIDE TO SEALANTS

ALUMINUM

NOTE: All sealants must be tooled to ensure proper adhesion.

## WATERPROOFING

- **33S ACETIC CURE SILICONE**

Sill to Subsill, End Dams, Screw Heads, and Threshold to Door Frame Sealing.

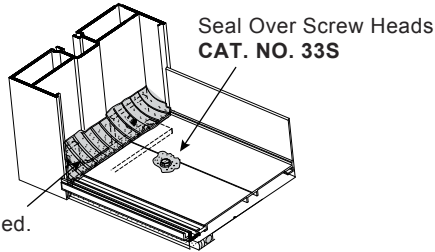

**NOTE:** Not for use near insulating glass units with butyl sealant.

## EXPANSION

- **95C SILICONE BUILDING SEALANT**

Expansion Joints.

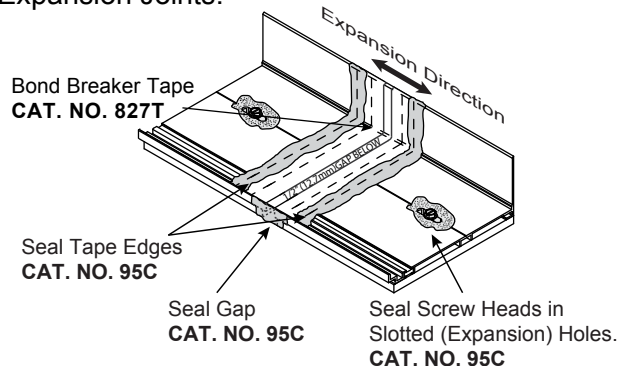

## JOINT ADHESIVE

- **RTV408 NEUTRAL CURE SILICONE**

Small Joints, End Joints and Buttered Surfaces, Water Diverters, End Dams, and Reglet Fills.

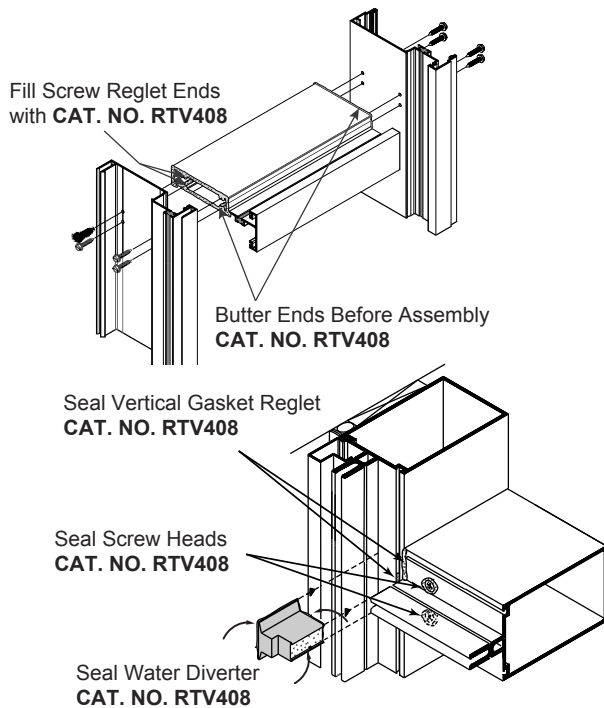

**NOTE:** I.G. butyl contact OK.

## PERIMETER

- **95C SILICONE BUILDING SEALANT (Preferred)**
- **M64 (SMOOTH) MODIFIED POLYURETHANE**
- **M66 (TEXTURED) MODIFIED POLYURETHANE**

Perimeter Seals, Expansion Joints, Sill and Threshold Beds, Concrete, Wood, and Steel Openings.

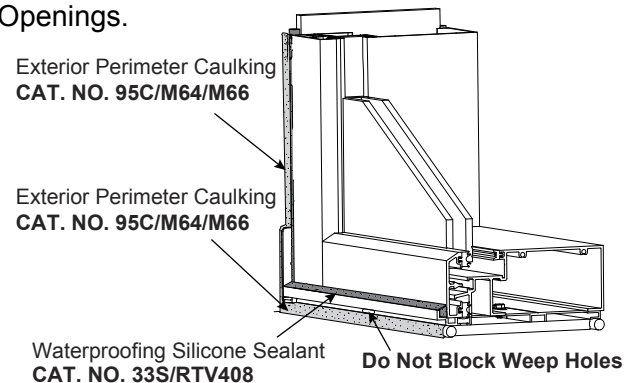

## STRUCTURAL

- **ALL STRUCTURAL SEALANTS REQUIRE TESTING AND APPROVAL.**

Glass-to-Glass or Glass-to-Metal

## SERIES 3150 CURTAIN WALL

---

This Concludes the Installation Manual for your product. We hope that this guide has been helpful. Should you need further assistance, our knowledgeable Technical Sales Department is available at no charge during regular business hours. Please have your Order Number ready before calling.



"WE'RE HERE TO HELP"  
**TECHNICAL SALES**  
**1-323-588-1281**

Or Visit our Websites at:  
**[www.crlaurence.com](http://www.crlaurence.com)** or  
**[www.usalum.com](http://www.usalum.com)**

**Glass and Glazing Assistance** .....Ext: 15275  
Tools, Hardware, Sealants, Safety Gear, U.V., and Equipment

**Architectural Hardware** .....Ext: 17700  
Entrances and Storefronts, Balanced, Stacking, and Sliding Doors

**Architectural and Ornamental Metals** .....Ext: 17700  
Formed Sheet Metal, Awnings, Columns, and Wall Panels

**Shower Doors** .....Ext: 17740  
Hinges, Handles, Enclosures, Grab Bars, and Partitions

**Transaction and Hospitality** .....Ext: 17760  
Bullet Resistant, Drive Thru, Sneeze Guards, and Speak Thrus

**Door and Window Control Hardware** .....Ext: 17520  
Jackson Overhead Concealed Closers, Surface Closures, Locks

**Blumcraft Architectural Metals** .....Ext: 17700  
Tempered Glass Doors, Panic Hardware, Glass Gates, and Baffles

**U.S. Aluminum** .....Ext: 15305  
Storefronts, Entrances, Curtain Walls, Window Walls, and Partitions

**Architectural Railings** .....Ext: 17730  
Cap, Hand, Post, Wind Screen, Base Shoe, and TaperLoc

**Automotive** .....Ext: 17780  
Automotive Glazing Supplies, Truck Sliders, and RV Windows