

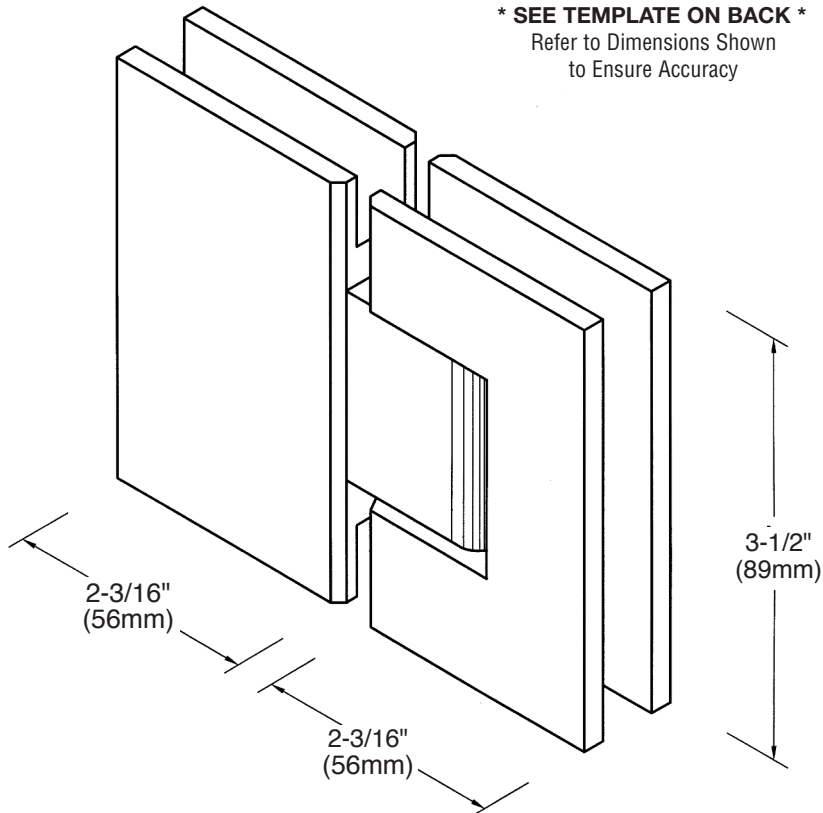

C.R. LAURENCE CO., INC.
PROFESSIONAL QUALITY

*** SEE TEMPLATE ON BACK ***
Refer to Dimensions Shown
to Ensure Accuracy



INTERNATIONAL

Square 180° Glass-to-Glass Hinge

CAT No. SGM1

*Maximum Door Capacities	5/16" (8mm) and 3/8" (10mm) Glass		1/2" (12mm) Glass	
	Weight	Width	Weight	Width
Using 2 Hinges	80 lbs.(36 kg)	28"(711mm)	80 lbs.(36 kg)	28"(711mm)
Using 3 Hinges	120 lbs.(54 kg)	32"(813mm)	120 lbs.(54 kg)	32"(813mm)

***NOTE:** Do not exceed either maximum weight or width when choosing proper quantity of hinges.

Important Information:

Door and fixed panel use same cutout.

Specifications:

Glass Sizes: 5/16" (8mm), 3/8" (10mm) and 1/2" (12mm) thick tempered safety glass

Construction: Solid brass

Closing Type: Self-centering when within 10° of closed position

Cutout Required

Includes: Gaskets, screws and template

Use of Gaskets:

For 5/16"(8mm) Glass: Use one thick and one thin gasket on each side

For 3/8"(10mm) Glass: Use one thick gasket on each side

For 1/2"(12mm) Glass: Use one thin gasket on each side

Recommendations:

For public safety, we recommend the use of only tempered safety glass.

Do not use power tools when installing these hinges.

Maintenance Guidelines:

- Our hinges are greased at the factory for quiet and trouble-free operation. If there is any squeaking that occurs after installation, put a drop of "3 in 1 Oil" (also known as "household oil") on the white nylon washer that the hinge body pivots on. This washer is the component that acts as a buffer, so the body of the hinge doesn't pivot directly on the brass center block. This solution doesn't require the disassembly of the hinge.
Note: Do not use spray lubricant on these hinges. If the hinge has been disassembled, upon re-assembly, use white lithium grease to lubricate the interior mechanism.
- Never use an abrasive cleaner on the hardware. Many of the components are coated with a clear lacquer that will be irreparably damaged if subjected to harsh, abrasive chemicals. Advise your customer that drying the hardware with a clean, soft towel on a daily basis is the best way to maintain the hardware. If mineral deposits build-up, mix a couple of drops of a mild liquid soap (such as Ivory or a similar product) into a cup of warm water. Using a soft, non-abrasive cloth, clean the hardware. Rinse thoroughly with clean, warm water and dry.



C.R. LAURENCE CO., INC.
PROFESSIONAL QUALITY

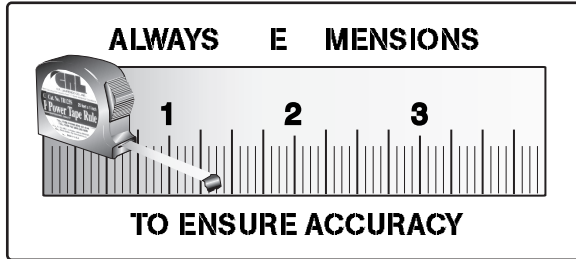

INTERNATIONAL

Square 180° Glass-to-Glass Hinge
 CAT No. SGM1

