

USE OF GASKETS	
FOR 5/16" (8mm) GLASS: USE TWO THICK GASKETS STAMPED WITH 8mm	
FOR 3/8" (10mm) GLASS: USE TWO GASKETS STAMPED WITH 12-10mm	
FOR 1/2" (12mm) GLASS: USE TWO GASKETS STAMPED WITH 12-10mm	

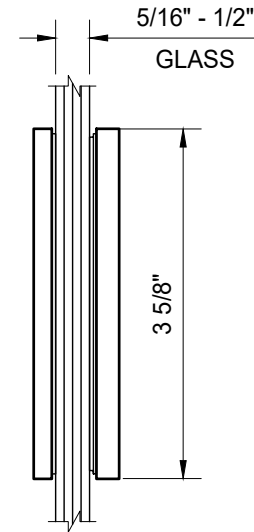
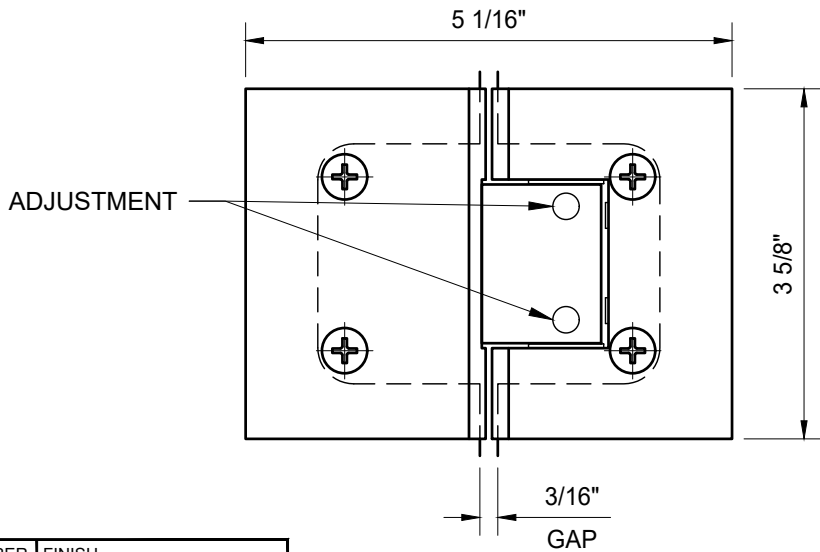
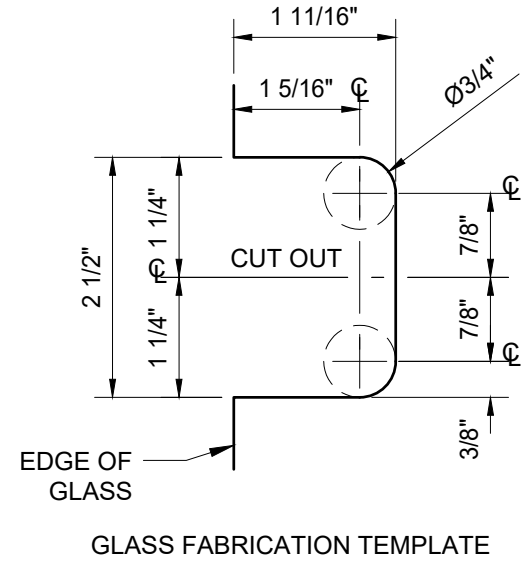
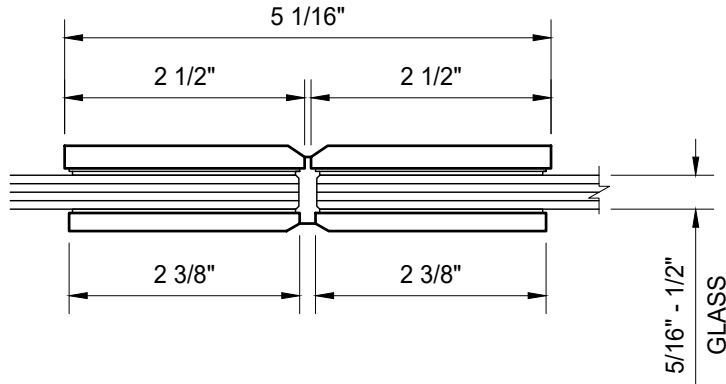

CATALOG NUMBER	FINISH
MEL3800RB	OIL RUBBED BRONZE
MEL380BN	BRUSHED NICKEL
MEL380CH	POLISHED CHROME
MEL380MBL	MATTE BLACK

MEL380XX - CRL MELBOURNE SERIES ADJUSTABLE GLASS TO GLASS MOUNT

DATE: 3/18/19  
 SCALE: 6"=1'-0"  
 DRAWN BY: VM

DESCRIPTION: CRL MEL380  
 CRL MELBOURNE SERIES HINGES  
 ADJUSTABLE 180° GLASS TO GLASS MOUNT

C.R.LAURENCE CO. ARCHITECTURAL PRODUCTS  
 2503 E. Vernon Avenue, Los Angeles, C.A 90058-1897  
 PH (800)-421-6144 FX: 800-587-7501 www.crlaurence.com

